

ANSI 900-2500 CLASS DIN PN160-PN400

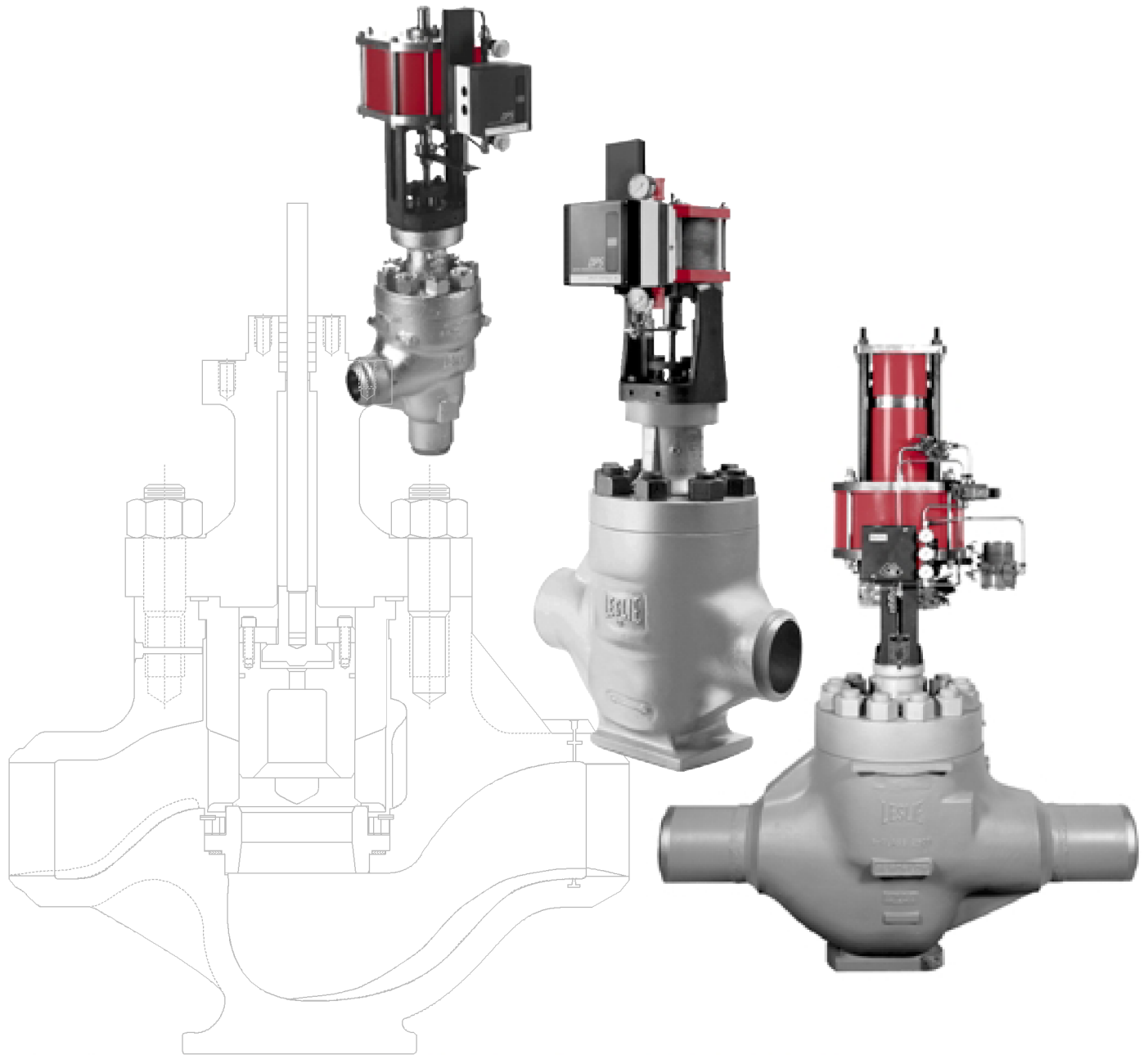

HIGH PERFORMANCE **AEROFLOW** CONTROL VALVES

LESLIE
CONTROLS, INC.

A subsidiary of CIRCOR International, Inc.

AEROFLOW

HIGH PERFORMANCE CONTROL VALVES ANSI 900-2500 CLASS



A subsidiary of CIRCOR International, Inc.

12501 Telecom Drive • Tampa, FL 33637-0906
Ph: (813) 978-1000 • Fax: (813) 977-0174

AEROFLOW HIGH PERFORMANCE CONTROL VALVES

Innovative Technology for the 21st Century

Leslie Aeroflow control valve family represent an integrated valve solution for the 1990's ... and beyond. Not a compromise or re-packaging of old valve technologies. The Aeroflow valve concept integrates proven state-of-the-art design in aerodynamic/hydrodynamic flow, field proven materials, digital positioning, and "smart" valve technology, with a modular design concept. The sum and benefit of Aeroflow's technological advances is simply the most accurate, reliable control valve product line available in the world today.

**Typical Globe Style Body
w/Pilot Balanced Trim**

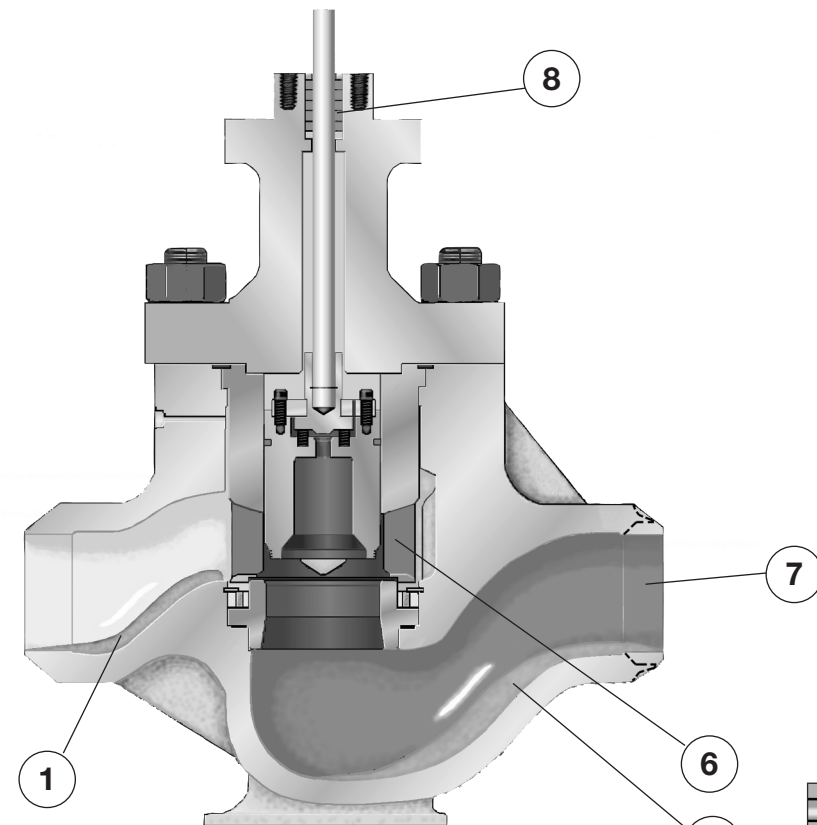

**Typical Angle Style Body
w/ High-Gain T² Trim**

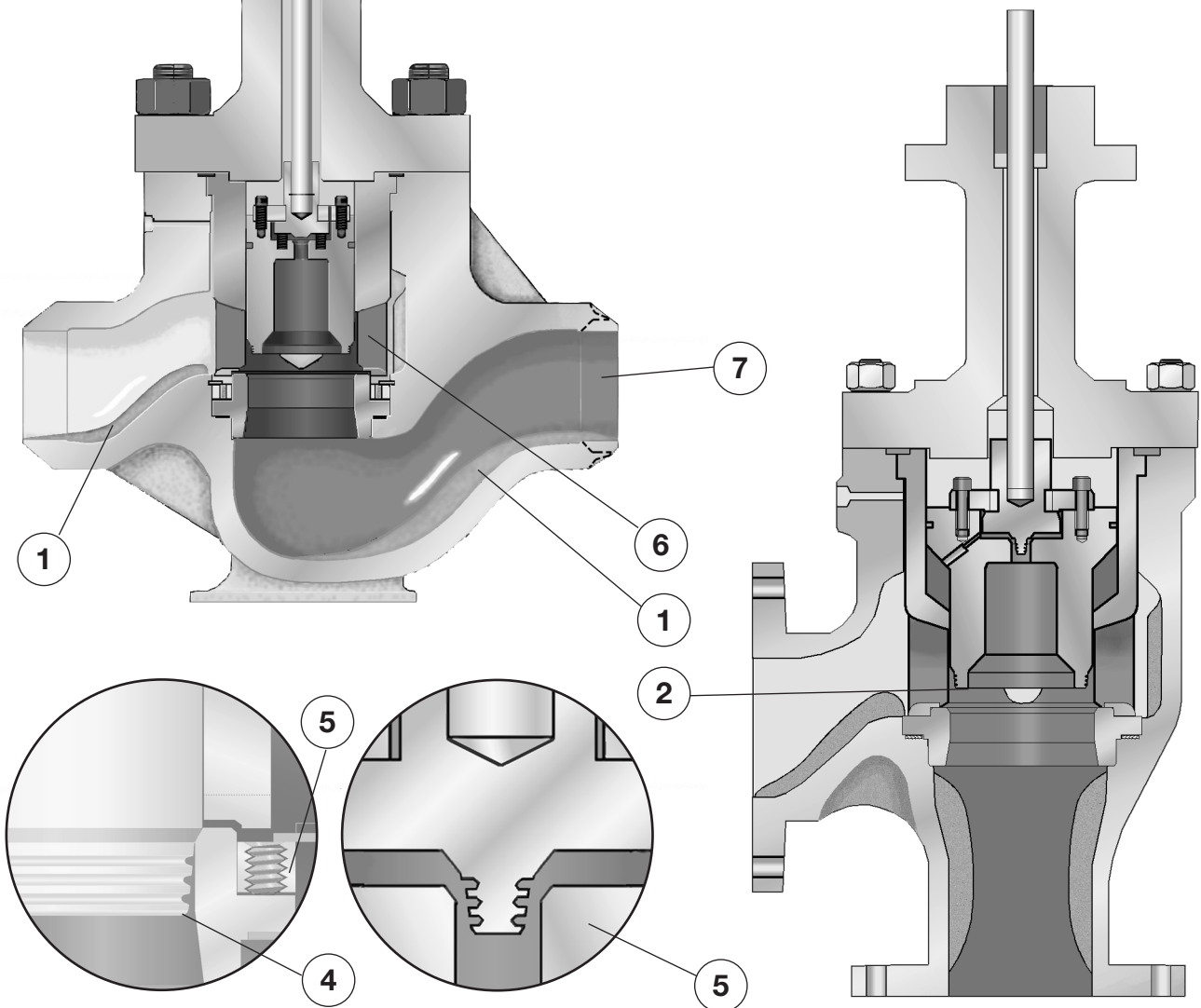

AEROFLOW HIGH PERFORMANCE CONTROL VALVES

Solution-Engineered Features for Demanding Applications

1. Aerodynamic Flow Control

Aerodynamic flow control vanes are integrally cast into the inlet and outlet passages of Aeroflow bodies. Inlet vanes promote a steady state flow profile and divert flow around the far side of the cage to provide Cv/size ratios previously not offered in cage guided control valves. Outlet vanes reduce flow turbulence minimizing body scouring as well as reducing valve generated noise.

2. Tight Shut-Off (exceeds ANSI Class VI - Zero cc/min.)

Even small seat leaks can only get worse with time. The key to preventing seat erosion and wire drawing is to prevent leakage to begin with. Unlike competitive valves rated for Class IV, V, or VI shut-off, Aeroflow's pressure energized pilot balanced plug provides zero cc/min leak rates, without penalty of huge actuators, even with metal to metal seats at full body pressure/temperature ratings. Aeroflow's shut-off capability is in a class all its own. The pilot balanced plug design minimizes actuator size and cost. Proven pilot design also eliminates the need for any piston seals to insure tight shut-off, greatly increasing the valve's reliability.

3. Parts Interchangeability

With the exception of bodies, all parts are interchangeable between globe and angle body styles with the same size and function. Balanced and unbalanced trim designs utilize the same body platforms. Facilities needing both globe and angle styles can minimize parts inventories, maintenance and training.

4. Tri-Sheer Protected Seat Design

Proven in more than 20 years of power plant service, Leslie's "protected" seat design protects Aeroflow's superior shut-off characteristic three ways. First, the protected seat prevents high velocity transients at opening or closure of the valve. Secondly, a five-stage pressure drop occurs near the seating position and last, the plug/seat surface is withdrawn from the direct flow to prevent direct particle impingement or clamping. The Tri-Sheer allows prolonged throttling at the seat without wire draw due to high clearance flow velocities.

5. Quick-Change Seat Design

In 4-16" body sizes, Aeroflow's seat ring is not threaded, welded, or loaded in place by the cage. Seat retention and seat gasket loading are accomplished with a stainless steel load ring and multiple silver-plated load screws for controlled seat gasket loading which is impervious to thermal shock.

6. Hung Cage for Thermal Expansion

The Quick-Change Seat features a cage which is hung in the body. This allows the cage to expand freely through sudden wide variations in fluid temperature. This tolerance for cage expansion solves the typical problems seen in cage retained designs such as cage warping, plug binding, galling, and crushed gaskets.

7. Custom Characterized Cage Throttling

Massive 400 Series stainless steel cage resists warping or deformation and provides plug/window throttling through closure. The flow window can be shaped to meet specific Cv requirements and system characteristics. This custom characterized cage is standard and is available with all plug/seat options.

Les-Sonic Cage

Single stage Les-Sonic cage can provide up to 25 dBA noise reduction in compressible fluid applications. When combined with a Les-Sonic Silencing Orifice (see bulletin 10/3.1.2) noise reductions of up to 35 dBA are possible.

Les-Cav Multi-Stage Cage

Les-Cav multi-stage trim is designed to throttle liquids with maximum pressure drops from 0-5000psi (345 bar) without damaging cavitation and resultant noise or vibration. Les-Cav is easily tailored to the exact requirements of each application.

Mini-P Multi-Stage Plug

The Mini-P multi-stage plug is designed for low-flow high-pressure drop cavitating services. The unique axial flow design will control cavitation and the resultant noise, vibration, and valve erosion damage. The pressure drop is taken along the length of the plug in the milled slots and chambered liner. The Mini-P can be easily tailored to the exact Cv requirements of each valve application.

C³ Combination Characterized Cage

Special characterized cages can be designed for applications that require high rangeability, with low end cavitation protection or low end noise abatement. This type of flexibility allows Leslie to provide one valve where other manufacturers may require two. This lowers overall equipment, installation, and maintenance costs.

8. Packing

Laminated Graphite

Precision die-cut laminated graphite rings provide a reliable, tight stem seal up to operating temperatures of 1050°F (565°C).

Braided Teflon Graphite (BTG)

Split rings allow packing replacement without removal of actuator. Graphite impregnated PTFE provides 500°F (260°C) service temperature, better "memory" and sealing than pure PTFE rings, lowered stem hysteresis, and is ideal for fluids that contain suspended particles.

9. Oversized Outlet Connection

Aeroflow's outlet can be machined to accept an outlet pipe nominally one size larger than valve body size. In many cases this saves the cost of an outlet reducer and eliminates one field weld.

10. "Smart Valve" Provisions

The key to "smart" valve technology is accurate measurement of valve inlet and outlet pressures. Optional "dead zone" inlet/outlet taps provide accurate, stable pressure measurements while eliminating adjacent piping penetration points.

AEROFLOW HIGH PERFORMANCE CONTROL VALVES

MODULAR TRIM

Aeroflow trim design allows you to choose the ideal cost/performance combination for each application. All trim modules are 100% field interchangeable providing extraordinary flexibility and value.

CAGE THROTTLING

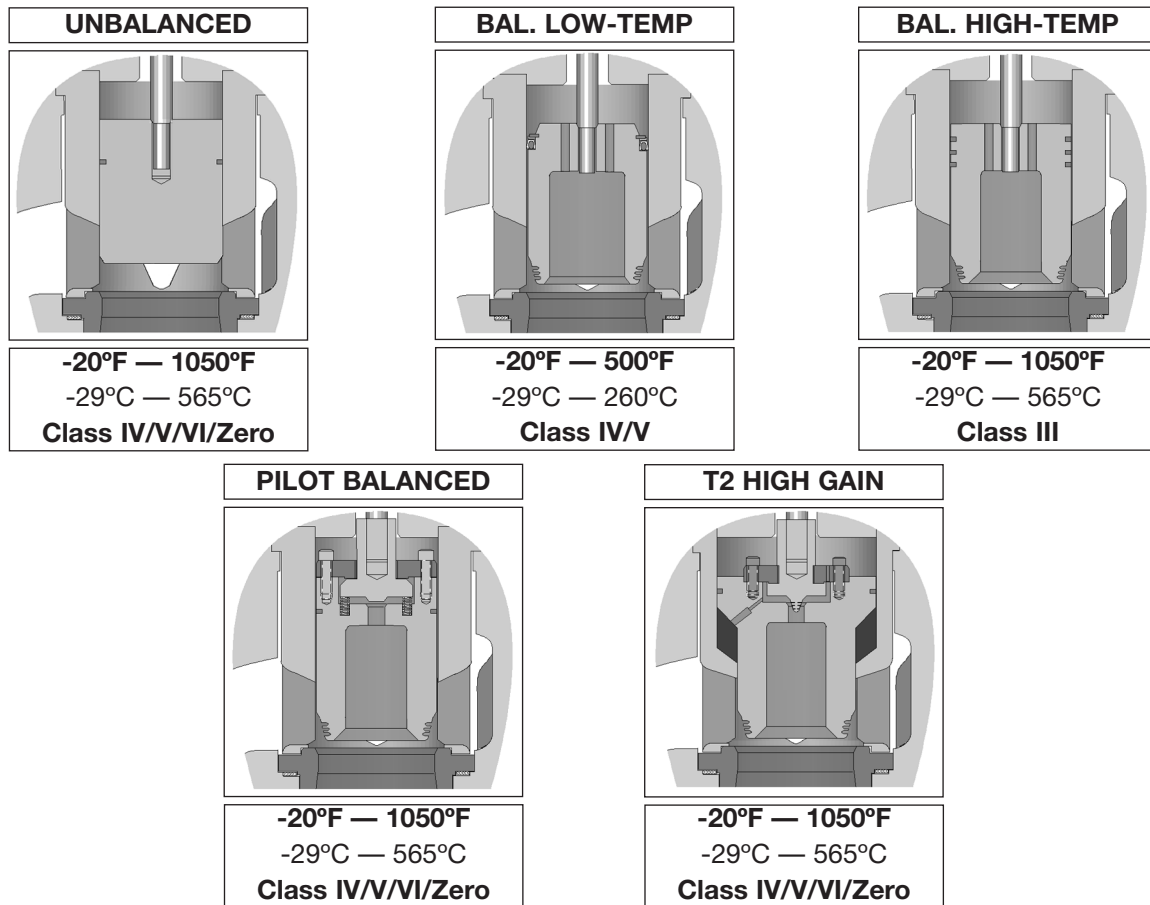

PLUG THROTTLING

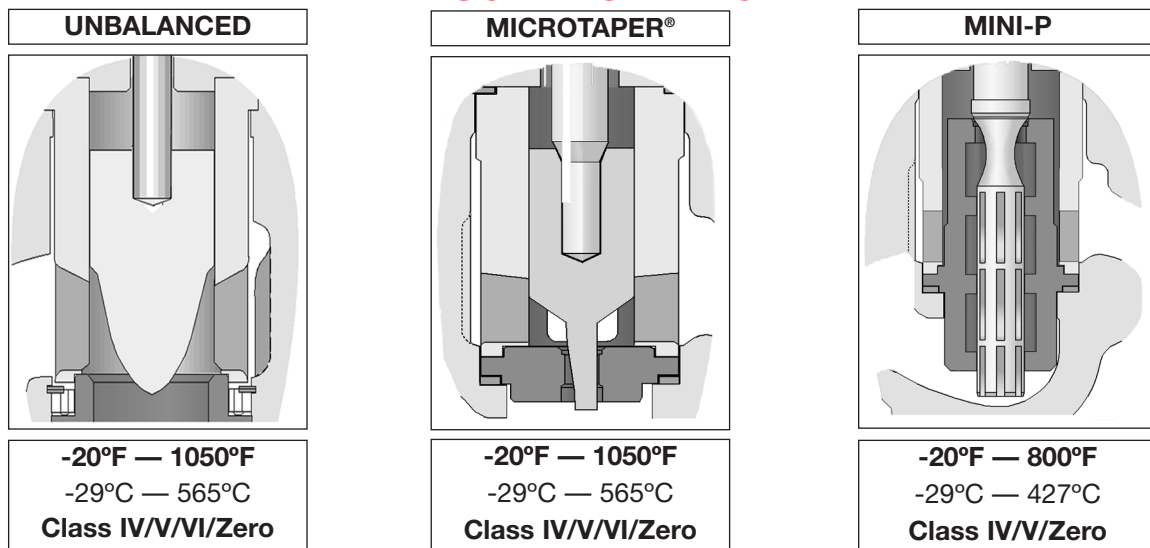

AEROFLOW HIGH PERFORMANCE CONTROL VALVES

END CONNECTIONS

Globe Type

Valve Size in/mm	Unbalanced Cage Thrott	Balanced Cage Thrott	T2	Unbalanced Plug Thrott	Micro/Taper Mini-P
1 / 25 1.5 / 40 2 / 50	S B RF RTJ	S B RF RTJ	S B RF RTJ	S RF RTJ S RF RTJ S B RF RTJ	S RF RTJ S RF RTJ
3 / 75 4 / 100 6 / 150	B RF RTJ B RF RTJ	B RF RTJ B RF RTJ B RF RTJ	B RF RTJ B RF RTJ B RF RTJ	B RF RTJ	
8 / 200 10 / 250 12 / 300		B RF RTJ B RF RTJ B RF RTJ	B RF RTJ		
14 / 350 16 / 400		B RF RTJ B RF RTJ			

Angle Type

Valve Size in/mm	Unbalanced Cage Thrott	Balanced Cage Thrott	T2	Unbalanced Plug Thrott	Micro/Taper Mini-P
1 / 25 1.5 / 40 2 / 50	S B RF RTJ	S B RF RTJ	S B RF RTJ	S RF RTJ S RF RTJ S B RF RTJ	S RF RTJ S RF RTJ
3 / 75 4 / 100 6 / 150	B RF RTJ B RF RTJ	B RF RTJ B RF RTJ B RF RTJ	B RF RTJ B RF RTJ B RF RTJ	B RF RTJ	
8 / 200		B RF RTJ	B RF RTJ		

S = Socket Weld End
B = Butt Weld End

RF = Raised Face Flanged
RTJ = Ring Type Joint

CUSTOM CHARACTERIZED CONTROL

FLOW CHARACTERISTICS - What kind of flow response do you need from your valve? Characterized positioner cams or custom control software are only partial characteristic solutions as neither can change a valve's inherent rangeability. The only total solution is a custom valve characteristic, which Aeroflow can provide quickly and economically.

REDUCED TRIM - INFINITE OPTIONS - With Aeroflow's advanced CAD/CAM manufacturing technologies you can specify exactly the capacity your application needs, with no penalty in cost or delivery. Whether for future planning requirements, velocity control, or establishing a precise control band (i.e., 32-84% open), Aeroflow provides you with custom control at standard costs and lead times. If one of our eight "standard" reduced trim options isn't ideal, simply specify one that is. Standard reduced trim is available in reductions of .9, .8, .7, .6, .5, .4, .3, and .2 of full Cv.

Standard Cage

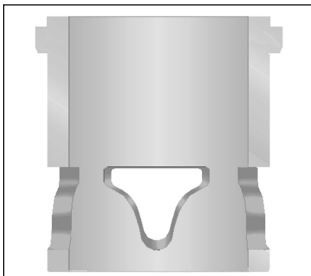

LesSonic Cage

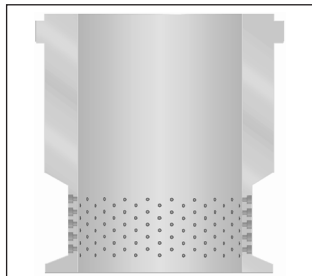

LesCav V Cage

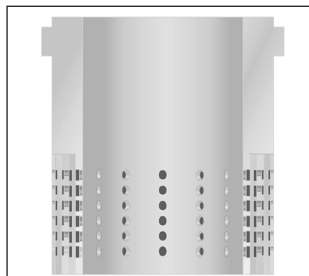

C³ Cage

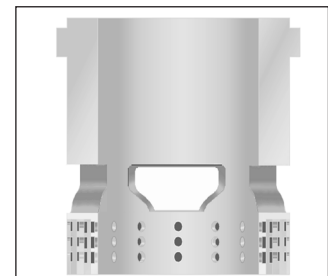

AEROFLOW HIGH PERFORMANCE CONTROL VALVES

Cv Tables - Linear Characteristics

UNBALANCED PLUG THROTTLING					Flow Characteristic - LINEAR										
Valve Size in/DN	Stroke in/mm	Stem Dia. in/mm	Seat Dia. in/mm	Min Cv STD/DPS ¹	RATED Cv @ PERCENT OF STROKE										
					10	20	30	40	50	60	70	80	90	100	
1 / 25	1 / 25	0.75 / 20	1.00 / 25	0.20/0.06	0.32	0.64	0.96	1.28	1.6	1.92	2.24	2.56	2.88	3.2	
					0.96	1.92	2.88	3.84	4.8	5.76	6.72	7.68	8.64	9.6	
					1.6	3.2	4.8	6.4	8	9.6	11.2	12.8	14.4	16	
1.5 / 40	1 / 25	0.75 / 20	1.50 / 40	0.20/0.10	0.6	1.2	1.8	2.4	3	3.6	4.2	4.8	5.4	6	
					1.8	3.6	5.4	7.2	9	10.8	12.6	14.4	16.2	18	
					3	6	9	12	15	18	21	24	27	30	
2 / 50	1.5 / 40	0.75 / 20	2.25 / 57	0.30/0.10	1.14	2.28	3.42	4.56	5.7	6.84	7.98	9.12	10.26	11.4	
					3.42	6.84	10.26	13.68	17.1	20.52	23.94	27.36	30.78	34.2	
					5.7	11.4	17.1	22.8	28.5	34.2	39.9	45.6	51.3	57	
3 / 80	2 / 50	0.75 / 20	3.00 / 80	0.40/0.20	2.4	4.8	7.2	9.6	12	14.4	16.8	19.2	21.6	24	
					7.2	14.4	21.6	28.8	36	43.2	50.4	57.6	64.8	72	
					12	24	36	48	60	72	84	96	108	120	

Note: Minimum, Intermediate, and Maximum Cv's are shown for reference. Custom Cv's are standard.

¹ Minimum controllable Cv's are based on use of standard pneumatic positioner(STD) or Leslie Digital Positioning System (DPS).

CAGE THROTTLING					Flow Characteristic - LINEAR										
Valve Size in/DN	Stroke in/mm	Stem Dia. ² in/mm	Seat Dia. in/mm	Min Cv STD/DPS ¹	RATED Cv @ PERCENT OF STROKE										
					10	20	30	40	50	60	70	80	90	100	
2 / 50	1.5 / 38	0.75 / 20	2.21/56	0.60/0.20	1.2	2.4	3.6	4.8	6	7.2	8.4	9.6	10.8	12	
					3.6	7.2	10.8	14.4	18	21.6	25.2	28.8	32.4	36	
					6	12	18	24	30	36	42	48	54	60	
3 / 80	2 / 51	0.75 / 20	2.96/75	0.80/0.30	2.6	5.2	7.8	10.4	13	15.6	18.2	20.8	23.4	26	
					7.8	15.6	23.4	31.2	39	46.8	54.6	62.4	70.2	78	
					13	26	39	52	65	78	91	104	117	130	
4 / 100	2 / 51	0.75 / 20	3.80/97	0.90/0.40	4	8	12	16	20	24	28	32	36	40	
					12	24	36	48	60	72	84	96	108	120	
					20	40	60	80	100	120	140	160	180	200	
6 / 150	3 / 76	1.00 / 25	5.31/135	1.40/0.60	9	18	27	36	45	54	63	72	81	90	
					27	54	81	108	135	162	189	216	243	270	
					45	90	135	180	225	270	315	360	405	450	
8 / 200	3/76	1.25 / 32	7.06/179	1.80/0.70	42	84	126	168	210	252	294	336	378	420	
					70	140	210	280	350	420	490	560	630	700	
					80	160	240	320	400	480	560	640	720	800	
10 / 250	3 / 76	1.25 / 32	8.5/216	5.02/2.00	61.2	122.4	183.6	244.8	306	367.2	428.4	489.6	550.8	612	
					102	204	306	408	510	612	714	816	918	1020	
					116	232	348	464	590	696	812	928	1044	1160	
12 / 300	4 / 102	1.25 / 32	8.5/216	5.02/2.00	78	15	234	312	390	468	546	624	702	780	
					130	260	390	520	650	780	910	1040	1170	1300	
					147	294	441	588	735	882	1029	1176	1323	1470	
14 / 350	3 / 76	1.25 / 32	11.86/301	7.50/3.75	99	198	297	396	495	594	693	792	891	990	
					165	330	495	660	852	990	1155	1320	1485	1650	
					195	390	585	780	975	1170	1365	1560	1755	1950	
16 / 400	3 / 76	1.25 / 32	12.5/318	7.50/3.75	111	222	333	444	555	666	777	888	999	1110	
					185	370	555	740	925	1110	1295	1480	1665	1850	
					220	440	660	880	1100	1320	1540	1760	1980	2200	

Note: Standard travel maximum, 0.6 and 0.2 factor Cv's are shown for reference in 2-6" valve sizes. Standard travel maximum and 0.6 Cv's are shown for reference in 8-16" valves sizes. Maximum Cv's shown for extended travel. **Custom Cv's are standard.**

¹ Minimum controllable Cv's are based on use of standard pneumatic positioner (STD or Leslie Digital Positioning System (DPS)).

² Stem diameter for T² trim is 1/2" for 2-6" sizes and 3/4" for 8" sizes.

AEROFLOW HIGH PERFORMANCE CONTROL VALVES

Cv Tables - Equal Percentage Characteristics

UNBALANCED PLUG THROTTLING					Flow Characteristic - EQUAL PERCENTAGE										
Valve Size in/DN	Stroke in/mm	Stem Dia. in/mm	Seat Dia. in/mm	Min Cv STD/DPS ¹	RATED Cv @ PERCENT OF STROKE										
					10	20	30	40	50	60	70	80	90	100	
1 / 25	1 / 25	0.75 / 20	1.00 / 25	0.20/0.06	0.10	0.13	0.26	0.38	0.51	0.74	0.99	1.44	2.14	3.2	
					0.29	0.38	0.77	1.15	1.54	2.21	2.98	4.32	6.43	9.6	
					0.48	0.64	1.28	1.92	2.56	3.68	4.96	7.2	10.72	16	
1.5 / 40	1 / 25	0.75 / 20	1.50 / 40	0.20/0.10	0.18	0.24	0.48	0.72	0.96	1.38	1.86	2.7	4.02	6	
					0.54	0.72	1.44	2.16	2.88	4.14	5.58	8.1	12.06	18	
					0.9	1.2	2.4	3.6	4.8	6.9	9.3	13.5	20.1	30	
2 / 50	1.5 / 40	0.75 / 20	2.25 / 57	0.30/0.10	0.34	0.46	0.91	1.37	1.82	2.62	3.53	5.13	7.64	11.4	
					1.03	1.37	2.74	4.1	5.47	7.87	10.6	15.39	22.91	34.2	
					1.71	2.28	4.56	6.84	9.12	13.11	17.67	25.65	38.19	57	
3 / 80	2 / 50	0.75 / 20	3.00 / 80	0.40/0.20	0.72	.096	1.92	2.88	3.84	5.52	7.44	10.8	16.08	24	
					2.16	2.88	5.76	8.64	11.52	16.56	22.32	32.4	48.24	72	
					3.6	4.8	9.6	14.4	19.2	27.6	37.2	54	80.4	120	

Note: Minimum, Intermediate, and Maximum Cv's are shown for reference. **Custom Cv's are standard.**

¹ Minimum controllable Cv's are based on use of standard pneumatic positioner(STD) or Leslie Digital Positioning System (DPS).

CAGE THROTTLING					Flow Characteristic - EQUAL PERCENTAGE										
Valve Size in/DN	Stroke in/mm	Stem Dia. ² in/mm	Seat Dia. in/mm	Min Cv STD/DPS ¹	RATED Cv @ PERCENT OF STROKE										
					10	20	30	40	50	60	70	80	90	100	
2 / 50	1.5 / 38	0.75 / 20	2.21/56	0.60/0.20	0.3	0.4	0.8	1.2	1.6	2.3	3.1	4.5	6.7	10	
					0.9	1.2	2.4	3.6	4.8	6.9	9.3	13.5	20.1	30	
					1.5	2	4	6	8	11.5	15.5	22.5	33.5	50	
3 / 80	2 / 51	0.75 / 20	2.96/75	0.80/0.30	0.72	0.96	1.92	2.88	3.84	5.52	7.44	10.8	16.1	24	
					2.16	2.88	5.76	8.64	11.52	16.56	22.32	32.4	48.24	72	
					3.6	4.8	9.6	14.4	19.2	27.6	37.2	54	80.4	120	
4 / 100	2 / 51	0.75 / 20	3.80/97	0.90/0.40	1.08	1.44	2.88	4.32	5.76	8.28	11.16	16.2	24.1	36	
					3.24	4.32	8.64	12.96	17.28	34.84	33.48	48.6	72.36	108	
					5.4	7.2	14.4	21.6	28.8	41.4	55.8	81	121	180	
6 / 150	3 / 76	1.00 / 25	5.31/135	1.40/0.60	2.4	3.2	6.4	9.6	12.8	18.4	24.9	36	53.6	80	
					7.2	9.6	19.2	28.8	38.4	55.2	74.4	108	160.8	240	
					12	16	32	48	64	92	124	180	268	400	
8/200	3 / 76	1.25 / 32	7.06/179	1.80/0.70	12.96	17.28	34.56	51.84	69.12	99.36	133.9	194.4	289.4	432	
					17.4	23.2	46.4	69.6	92.8	133.4	179.8	261	388.6	580	
					21.6	28.8	57.6	86.4	115.2	165.6	223.2	324	482.4	720	
10 / 250	3 / 76	1.25 / 32	8.5/216	5.02/2.00	18.72	24.96	49.92	74.88	99.84	143.5	193.4	280.8	418.1	624	
					25.5	34	68	102	136	195.5	263.5	382.5	569.5	850	
					31.2	41.6	83.2	124.8	166.4	239.2	322.4	468	696.8	1040	
12 / 300	3 / 102	1.25 / 32	10/254	6.00/2.60	23.76	31.68	63.36	95.04	126.7	182.2	245.5	356.4	530.6	792	
					32.4	43.2	86.4	129.6	172.8	248.4	334.8	486	723.6	1080	
					39.6	52.8	105.6	158.4	211.2	303.6	409.2	594	884.4	1320	
14 / 350	3 / 76	1.25 / 32	11.86/301	7.50/3.75	31.5	42	84	126	168	241.5	325.5	472.5	703.5	1050	
					41.1	54.8	109.6	164.4	219.2	315.1	424.7	616.5	917.9	1370	
					52.5	70	140	210	280	402.5	542.5	787.5	1173	1750	
16 / 400	3 / 76	1.25 / 32	12.5/318	7.50/3.75	35.64	47.52	95.04	142.6	190.1	273.2	368.3	534.6	796	1188	
					45.9	61.2	122.4	183.6	244.8	351.9	474.3	688.5	1025	1530	
					59.4	79.2	158.4	237.6	316.8	455.4	613.8	891	1327	1980	

Note: Standard travel maximum, 0.6 and 0.2 factor Cv's are shown for reference in 2-6" valve sizes. Standard travel maximum and 0.6 Cv's are shown for reference in 8-16" valves sizes. Maximum Cv's shown for extended travel. **Custom Cv's are standard.**

¹ Minimum controllable Cv's are based on use of standard pneumatic positioner(STD) or Leslie Digital Positioning System (DPS).

² Stem diameter for T² trim is 1/2" for 2-6" sizes and 3/4" for 8" sizes.

AEROFLOW HIGH PERFORMANCE CONTROL VALVES

Cv Tables - Anti-Noise Characteristic

LES-SONIC CAGE THROTTLING					Flow Characteristic - LINEAR		
Valve Size in/DN	Stroke in/mm	Stem Dia. ¹ in/mm	Seat Dia. in/mm	Min Cv	ΔP/P1		
					≤ 0.6	>0.6 ≤ 0.8	>0.8 ≤ 0.99
2 / 50	1.5 / 38	0.75 / 20	2.21 / 56	0.60	45	30	17
2 / 50	2 / 51	0.75 / 20	2.21 / 56	0.60	60	40	23
3 / 80	2 / 51	0.75 / 20	2.96 / 75	0.80	100	55	30
3 / 80	3 / 76	0.76 / 20	2.96 / 76	0.80	150	82	45
4 / 100	2 / 51	0.75 / 20	3.80 / 97	0.90	150	75	40
4 / 100	3 / 76	0.76 / 20	3.80 / 97	0.90	225	110	60
6 / 150	3 / 76	1.00 / 25	5.31 / 135	1.40	330	150	85
6 / 150	4 / 102	1.00 / 25	5.31 / 135	1.40	440	200	115
8 / 200	3 / 76	1.25 / 32	7.06 / 179	1.80	430	200	110
8 / 200	4 / 102	1.25 / 32	7.06 / 179	1.80	575	265	150
8 / 200	5 / 127	1.25 / 32	7.06 / 179	1.80	720	330	180
10 / 250	3 / 76	1.25 / 32	8.5 / 216	5.02	535	240	135
10 / 250	4 / 102	1.25 / 32	8.5 / 216	5.02	720	320	180
10 / 250	5 / 127	1.25 / 32	8.5 / 216	5.02	890	400	225
12 / 300	3 / 76	1.25 / 32	10 / 254	6.00	620	280	160
12 / 300	4 / 102	1.25 / 32	10 / 254	6.00	830	375	210
12 / 300	5 / 127	1.25 / 32	10 / 254	6.00	1030	470	270
14 / 350	3 / 76	1.25 / 32	11.86 / 301	7.50	760	340	190
14 / 350	4 / 102	1.25 / 32	11.86 / 301	7.50	1010	450	250
14 / 350	5 / 127	1.25 / 32	11.86 / 301	7.50	1270	570	315
16 / 400	3 / 76	1.25 / 32	12.5 / 318	7.50	790	350	200
16 / 400	4 / 102	1.25 / 32	12.5 / 318	7.50	1060	465	270
16 / 400	5 / 127	1.25 / 32	12.5 / 318	7.50	1320	585	335

¹ Stem diameter for T² trim is 1/2" for 2-6" sizes and 3/4" for 8" size.

AEROFLOW HIGH PERFORMANCE CONTROL VALVES

Cv Tables - Anti-Cavitation Characteristic

LES-CAV I CAGE THROTTLING					Flow Characteristic - LINEAR									
Valve Size in/DN	Stroke in/mm	Stem Dia. ¹ in/mm	Seat Dia. in/mm	Min Cv STD/DPS ¹	RATED Cv @ PERCENT OF STROKE									
					10	20	30	40	50	60	70	80	90	100
2 / 50	1.5 / 38	0.75 / 20	2.2 / 56	0.60	2.4	4.8	7.2	9.6	12	14.4	16.8	19.2	21.6	24
					4	8	12	16	20	24	28	32	36	40
2 / 50	2 / 51	0.75 / 20	2.2 / 56	0.60	5.2	10.4	15.6	20.8	26	31.2	36.4	41.6	46.8	52
3 / 80	2 / 51	0.75 / 20	2.96/75	0.80	4.5	9	13.5	18	22.5	27	31.5	36	40.5	45
					7.5	15	22.5	30	37.5	45	52.5	60	67.5	75
3 / 80	3 / 76	0.75 / 20	2.96/75	0.80	11	22	33	44	55	66	77	88	99	110
4 / 100	2 / 51	0.75 / 20	3.80/93	0.90	5.7	11.4	17.1	22.8	28.5	34.2	39.9	45.6	51.3	57
					9.5	19	28.5	38	47.5	57	66.5	76	85.5	95
4 / 10	3 / 76	0.75 / 20	3.80/93	0.90	14	28	42	56	70	84	98	112	126	140
6 / 150	3 / 76	1 / 25	5.31/135	1.40	12	24	36	48	60	72	84	96	108	120
					20	40	60	80	100	120	140	160	180	200
6 / 150	4 / 102	1 / 25	5.31/135	1.40	26.5	53	79.5	106	132.5	159	185.5	212	238.5	265
8 / 200	3 / 76	1.25 / 32	7.06/179	1.80	27	54	81	108	135	162	189	216	243	270
					34	68	102	136	170	204	238	272	306	340
8 / 200	4 / 102	1.25 / 32	7.06/179	1.80	43	86	129	172	215	258	301	344	387	430
					43	86	129	172	215	258	301	344	387	430
10 / 250	3 / 76	1.25 / 32	8.50/216	5.02	32	64	96	128	160	192	224	256	288	320
					42.5	85	127.5	170	212.5	255	297.5	340	382.5	425
10 / 250	4 / 102	1.25 / 32	8.50/216	5.02	53	106	159	212	265	318	371	424	477	530
					53	106	159	212	265	318	371	424	477	530
12 / 300	3 / 76	1.25 / 32	10/254	5.6	37	74	111	148	185	222	259	296	333	370
					49	98	147	196	245	294	343	392	441	490
12 / 300	4 / 102	1.25 / 32	10/254	5.6	62	124	186	248	310	372	434	496	558	620
					62	124	186	248	310	372	434	496	558	620
16 / 400	3 / 76	1.25 / 32	12.5/318	6.9	47	94	141	188	235	282	329	376	423	470
					63	126	189	252	315	378	441	504	567	630
16 / 400	4 / 102	1.25 / 32	12.5/318	6.9	78	156	234	312	390	468	546	624	702	780
					78	156	234	312	390	468	546	624	702	780

Note: Standard travel maximum and 0.6 factor Cv's are shown in 2-6" valve size for reference. Maximum Cv's are shown otherwise. **Custom Cv's are standard.**

¹ Stem diameter for T² trim is 1/2" for 2-6" sizes and 3/4" for 8" sizes.

LES-CAV II CAGE THROTTLING					Flow Characteristic - LINEAR									
Valve Size in/DN	Stroke in/mm	Stem Dia. ¹ in/mm	Seat Dia. in/mm	Min Cv STD/DPS ¹	RATED Cv @ PERCENT OF STROKE									
					10	20	30	40	50	60	70	80	90	100
2 / 50	1.5 / 38	0.75 / 20	2.21/56	0.60	0.9	1.8	2.7	3.6	4.5	5.4	6.3	7.2	8.1	9
					1.5	3	4.5	6	7.5	9	10.5	12	13.5	15
2 / 50	2 / 51	0.75 / 20	2.21/56	0.60	2	4	6	8	10	12	14	16	18	20
3 / 80	2 / 51	0.75 / 20	2.96/75	0.80	1.68	3.36	5.04	6.72	8.4	10	11.76	13.4	15.1	16.8
					2.8	5.6	8.4	11.2	14	16.8	19.6	22.4	25.2	28
3 / 80	3 / 76	0.75 / 20	2.96/75	0.80	4.8	9.6	14.4	19.2	24	28.8	33.6	38.4	43.2	48
4 / 100	2 / 51	0.75 / 20	3.80/93	0.90	2.7	5.4	8.1	10.8	13.5	16.2	18.9	21.6	24.3	27
					4.5	9	13.5	18	22.5	27	31.5	36	40.5	45
4 / 100	3 / 76	0.75 / 20	3.80/93	0.90	7.6	15.2	22.8	30.4	38	45.6	53.2	60.8	68.4	76
6 / 150	3 / 76	1 / 25	5.31/135	1.40	6.6	13.2	19.8	26.4	33	39.6	46.2	52.8	59.4	66
					11	22	33	44	55	66	77	88	99	110
6 / 150	4 / 102	1 / 25	5.31/135	1.40	17.5	35	52.5	70	87.5	105	122.5	140	157.5	175
8 / 200	3 / 76	1.25 / 32	7.06/179	1.80	9	18	27	36	45	54	63	72	81	90
					15	30	45	60	75	90	105	120	135	150
8 / 200	4 / 102	1.25 / 32	7.06/179	1.80	22.5	45	67.5	90	112.5	135	157.5	180	202.5	225
					30	60	90	120	150	180	210	240	270	300
10 / 250	3 / 76	1.25 / 32	8.50/216	5.02	11.1	22.2	33.3	44.4	55.5	66.6	77.7	88.8	99.9	111
					18.5	37	55.5	74	92.5	111	129.5	148	166.5	185
10 / 250	4 / 102	1.25 / 32	8.50/216	5.02	25	50	75	100	125	150	175	200	225	250
					31	62	93	124	155	186	217	248	279	310
12 / 300	3 / 76	1.25 / 32	10/254	6.0	12.6	25.2	37.8	50.4	63	75.6	88.2	100.8	113.4	126
					21	42	63	84	105	126	147	168	189	210
12 / 300	4 / 102	1.25 / 32	10/254	5.6	28	56	84	112	140	168	196	224	252	280
					35	70	105	140	175	210	245	280	315	350

Note: Standard travel maximum and 0.6 factor Cv's are shown for reference. Maximum Cv's are shown otherwise. **Custom Cv's are standard.**

¹ Stem diameter for T² trim is 1/2" for 2-6" sizes and 3/4" for 8" sizes.

AEROFLOW HIGH PERFORMANCE CONTROL VALVES

Cv Tables - Anti-Cavitation Characteristics (cont'd)

LES-CAV III CAGE THROTTLING					Flow Characteristic - LINEAR									
Valve Size in/DN	Stroke in/mm	Stem Dia. ¹ in/mm	Seat Dia. in/mm	Min Cv STD/DPS ¹	RATED Cv @ PERCENT OF STROKE									
					10	20	30	40	50	60	70	80	90	100
2 / 50	1.5 / 38	0.75 / 20	2.21/56	0.60	0.54	1.08	1.62	2.16	2.7	3.24	3.78	4.32	4.86	5.4
					0.9	1.8	2.7	3.6	4.5	5.4	6.3	7.2	8.1	9
2 / 50	2 / 51	0.75 / 20	2.21/56	0.60	1.2	2.4	3.6	4.8	6	7.2	8.4	9.6	10.8	12
3 / 80	2 / 51	0.75 / 20	2.96/75	0.80	1.08	2.16	3.24	4.32	5.4	6.48	7.56	8.64	9.72	10.8
					1.8	3.6	5.4	7.2	9	10.8	12.6	14.4	16.2	18
3 / 80	3 / 76	0.75 / 20	2.96/75	0.80	2.8	5.6	8.4	11.2	14	16.8	19.6	22.4	25.2	28
4 / 100	2 / 51	0.75 / 20	3.80/93	0.90	1.62	3.24	4.86	6.48	8.1	9.72	11.3	13	14.6	16.2
					2.7	5.4	8.1	10.8	13.5	16.2	18.9	21.6	24.3	27
4 / 100	3 / 76	0.75 / 20	3.80/93	0.90	4.6	9.2	13.8	18.4	23	27.6	32.2	36.8	41.4	46
6 / 150	3 / 76	1 / 25	5.31/135	1.40	3.48	6.96	10.4	13.9	17.4	20.9	24.4	27.8	31.3	34.8
					5.8	11.6	17.4	23.2	29	34.8	40.6	46.4	52.2	58
6 / 150	4 / 102	1 / 25	5.31/135	1.40	9	18	27	36	45	54	63	72	81	90
8 / 200	3 / 76	1.25 / 32	7.06/179	1.80	6.36	12.72	19.1	25.4	31.8	38.2	44.6	50.9	57.2	63.6
					10.6	21.2	31.8	42.4	53	63.6	74.2	84.8	95.4	106
8 / 200	4 / 1023	1.25 / 32	7.06/179	1.80	14	28	42	56	70	84	98	112	126	140
8 / 200	5 / 1273	1.25 / 32	7.06/179	1.80	18	36	54	72	90	108	126	144	162	180

Note: Maximum and 0.6 factor Cv's are shown for reference. **Custom Cv's are standard.**

¹ Stem diameter for T² trim is 1/2" for 2-6" sizes and 3/4" for 8" sizes.

LES-CAV IV CAGE THROTTLING					Flow Characteristic - LINEAR									
Valve Size in/DN	Stroke in/mm	Stem Dia. ¹ in/mm	Seat Dia. in/mm	Min Cv STD/DPS ¹	RATED Cv @ PERCENT OF STROKE									
					10	20	30	40	50	60	70	80	90	100
2 / 50	1.5 / 38	0.75 / 20	2.21/56	0.60	0.36	0.72	1.08	1.44	1.8	2.16	2.52	2.88	3.24	3-6
					0.6	1.2	1.8	2.4	3	3.6	4.2	4.8	5.4	6
2 / 50	2 / 51	0.75 / 20	2.21/56	0.60	0.7	1.4	2.1	2.8	3.5	4.2	4.9	5.6	6.3	7
3 / 80	2 / 51	0.75 / 20	2.96/75	0.80	0.6	1.2	1.8	2.4	3	3.6	4.2	4.8	5.4	6
					1	2	3	4	5	6	7	8	9	10
3 / 80	3 / 76	0.75 / 20	2.96/75	0.80	1.4	2.8	4.2	5.6	7	8.4	9.8	11.2	12.6	14
4 / 100	2 / 51	0.75 / 20	3.80/93	0.90	1.08	2.16	3.24	4.32	5.4	6.48	7.56	8.64	9.72	10.8
					1.8	3.6	5.4	7.2	9	10.8	12.6	14.4	16.2	18
4 / 100	3 / 76	0.75 / 20	3.80/93	0.90	2.6	5.2	7.8	10.4	13	15.6	18.2	20.8	23.4	26
6 / 150	3 / 76	1 / 25	5.31/135	1.40	2.28	4.56	6.84	9.12	11.4	13.7	16	18.2	20.5	22.8
					3.8	7.6	11.4	15.2	19	22.8	26.6	30.4	34.2	38
6 / 150	3 / 76	1 / 25	5.31/135	1.40	6	12	18	24	30	36	42	48	54	60
8 / 200	3 / 76	1.25 / 32	7.06/179	1.80	3.48	6.96	10.44	13.92	17.4	20.9	24.4	27.8	31.3	34.8
					5.8	11.6	17.4	23.2	29	34.8	40.6	46.4	52.2	58
8 / 200	4 / 102	1.25 / 32	7.06/179	1.80	8.7	17.4	26.1	34.8	43.5	52.2	60.9	69.6	78.3	87
8 / 200	5 / 127	1.25 / 32	7.06/179	1.80	11.6	23.2	34.8	46.4	58	69.6	81.2	92.8	104	116

Note: Maximum and 0.6 factor Cv's are shown for reference. **Custom Cv's are standard.**

¹ Stem diameter for T² trim is 1/2" for 2-6" sizes and 3/4" for 8" sizes.

AEROFLOW HIGH PERFORMANCE CONTROL VALVES

Cv Tables - Anti-Cavitation Characteristics (cont'd)

LES-CAV V CAGE THROTTLING					Flow Characteristic - LINEAR									
Valve Size in/DN	Stroke in/mm	Stem Dia. ¹ in/mm	Seat Dia. in/mm	Min Cv	RATED Cv @ PERCENT OF STROKE									
					10	20	30	40	50	60	70	80	90	100
2/50	1.5 / 38	0.75/ 20	2.21/56	0.60	0.24	0.48	0.72	0.96	1.2	1.44	1.68	1.92	2.16	2.4
					0.4	0.8	1.2	1.6	2	2.4	2.8	3.2	3.6	4
2/50	2 / 51	0.75/20	2.21/56	0.60	0.6	1.2	1.8	2.4	3	3.6	4.2	4.8	5.4	6
3/80	2/51	0.75 /20	2.96/75	0.80	0.48	0.96	1.44	1.92	2.4	2.88	3.36	3.84	4.32	4.8
					0.8	1.6	2.4	3.2	4	4.8	5.6	6.4	7.2	8
3/80	3 / 76	0.75 /20	2.96/75	0.80	1.2	2.4	3.6	4.8	6	7.2	8.4	9.6	10.8	12
4/ 100	2 / 51	0.75 /20	3.80/93	0.90	0.78	1.56	2.34	3.12	3.9	4.68	5.46	6.24	7.02	7.8
					1.3	2.6	3.9	5.2	6.5	7.8	9.1	10.4	11.7	13
4 / 100	3 / 76	0.75 / 20	3.80/93	0.90	2.2	4.4	6.6	8.8	11	13.2	15.4	17.6	19.8	22
6 / 150	3/ 76	1 / 25	5.31/135	1.40	1.68	3.36	5.04	6.72	8.4	10.1	11.8	13.4	15.1	16.8
					2.8	5.6	8.4	11.2	14	16.8	19.6	22.4	25.2	28
6/ 150	4/ 102	1 /25	5.31/135	1.40	5.2	10.4	15.6	20.8	26	31.2	36.4	41.6	46.8	52
8 / 200	3 / 76	1.25 / 32	7.06/179	1.80	3	6	9	12	15	18	21	24	27	30
					5	10	15	20	25	30	35	40	45	50
8 / 200	4 / 102	1.25 / 32	7.06/179	1.80	7.5	15	22.5	30	37.5	45	52.5	6	67.5	75
8 / 200	5 / 127	1.25 / 32	7.06/179	1.80	10	20	30	40	50	60	70	80	90	100

Note: Maximum and 0.6 factor Cv's are shown for reference. Maximum Cv's shown for extended travel. **Custom Cv's are standard.**

¹ Stem diameter for T² trim is 1/2" for 2-6" sizes and 3/4" for 8" sizes.

Cv Tables - Mini-P/Microtaper® Characteristic

MINI-P (3-STAGE) PLUG THROTTLING					Flow Characteristic - LINEAR									
Valve Size in/DN	Stroke in/mm	Stem Dia. in/mm	Seat Dia. in/mm	Min Cv	RATED Cv @ PERCENT OF STROKE									
					10	20	30	40	50	60	70	80	90	100
1/25	0.75/20	0.75/20	0.875/22	0.08	0.12	0.24	0.36	0.48	0.6	0.72	0.84	0.96	10.8	1.2
					0.3	0.6	0.9	1.2	1.5	1.8	2.1	2.4	2.7	3
					0.5	1	1.5	2	2.5	3	3.5	4	4.5	5
1.5/40	0.75/20	0.75/20	0.875/22	0.08	0.12	0.24	0.36	0.48	0.6	0.72	0.84	0.96	10.8	1.2
					0.3	0.6	0.9	1.2	1.5	1.8	2.1	2.4	2.7	3
					0.5	1	1.5	2	2.5	3	3.5	4	4.5	5

MICROTAPER® PLUG THROTTLING					Flow Characteristic - LINEAR									
Valve Size in/DN	Stroke in/mm	Stem Dia. in/mm	Seat Dia. in/mm	Min Cv	RATED Cv @ PERCENT OF STROKE									
					10	20	30	40	50	60	70	80	90	100
1/25	0.75/20	0.75/20	0.375/9.5	0.01	0.03	0.06	0.09	0.12	0.15	0.18	0.21	0.24	0.27	0.3
					0.06	0.12	0.18	0.24	0.3	0.36	0.42	0.48	0.54	0.6
					0.12	0.24	0.36	0.48	0.6	0.72	0.84	0.96	1.08	1.2
1.5/40	75/20	0.75/20	0.375/9.5	0.02	0.03	0.06	0.09	0.12	0.15	0.18	0.21	0.24	0.27	0.3
					0.06	0.12	0.18	0.24	0.3	0.36	0.42	0.48	0.54	0.6
					0.12	0.24	0.36	0.48	0.6	0.72	0.84	0.96	1.08	1.2

AEROFLOW HIGH PERFORMANCE CONTROL VALVES

**Packing Box Detail w/
BTG Packing**

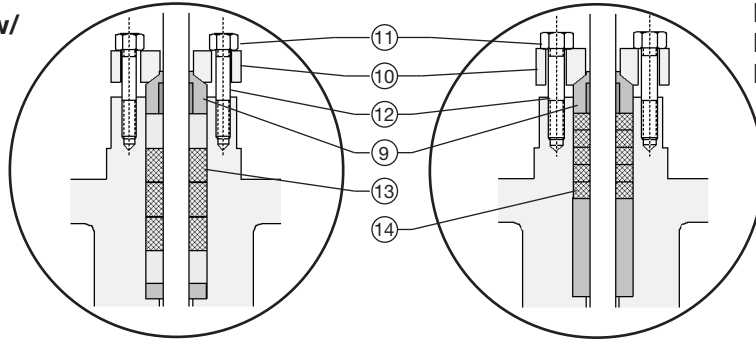

**Packing Box Detail w/
Laminated Graphite
Packing**

**MicroTaper®
Trim**

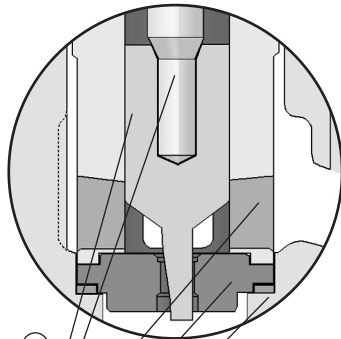

- 1
- 2
- 4
- 5
- 17

Load Ring Detail
(Cage Throttling
4" Valve Size Only)

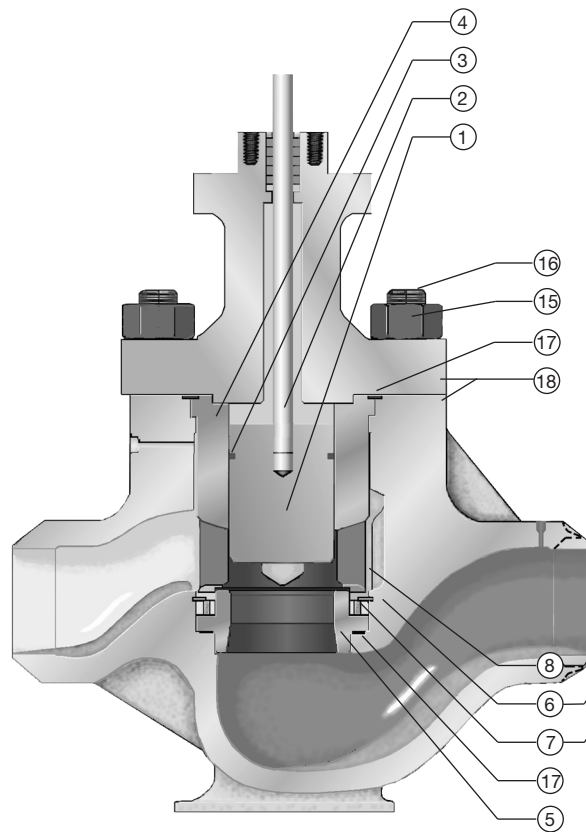
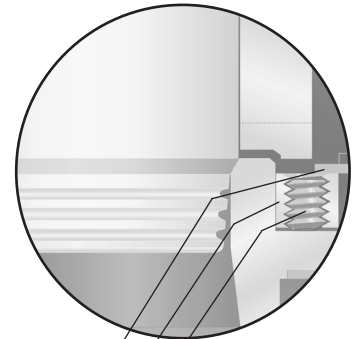

Body/bonnet Module
shown with
**Unbalanced Cage
Throttling Trim**

**Unbalanced
Plug Throttling
Trim**

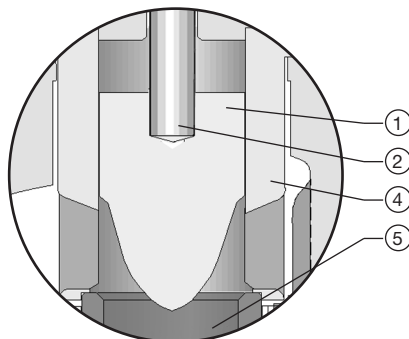

- 1
- 2
- 4
- 5

**Mini-P
Multi-Stage
Plug Throttling
Trim**

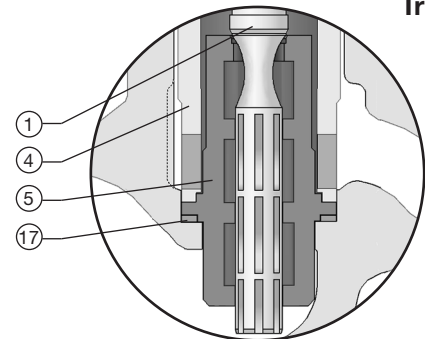

- 1
- 4
- 5
- 17

AEROFLOW HIGH PERFORMANCE CONTROL VALVES

Materials/Temperature Specifications

Unbalanced Trim

No.	Description	Material Specification	Operational Temp. Range
Trim Modules - Standard Materials			
Unbalanced Cage Throttling			
1	Valve Plug	AISI 420 Stainless Steel	-20 — 1050F (-29 — 565C)
2	*Valve Stem	Nitronic 60 [®]	-20 — 1050F (-29 — 565C)
3	Piston Ring	Stellite [®]	-20 — 1050F (-29 — 565C)
4	*Cage	AISI 440 Stainless Steel	-20 — 800F (-29 — 427C)
4	*Cage	AISI 440 Stainless Steel (Malcolmized)	800 — 1050F (427 — 565C)
5	*Seat Ring	AISI 440 Stainless Steel	-20 — 1050F (-29 — 565C)
6	¹ Load Ring	AISI410 Stainless Steel	-20 — 1050F (-29 — 565C)
7	¹ Load Screws	300 Series Stainless Steel	-20 — 1050F (-29 — 565C)
8	¹ Retaining Ring	AISI 302 Stainless Steel	-20 — 1050F (-29 — 565C)
Mini-P			
1	Valve Plug	13-8 MO Stainless Steel	-20 — 800F (-29 — 427C)
5	Seat Ring	AISI 440 Stainless Steel	-20 — 800F (-29 — 427C)
Microtaper[®]			
1	Valve Plug	AISI 431 Stainless Steel	-20 — 1050F (-29 — 565C)
Trim Modules - NACE Materials			
Unbalanced Cage Throttling			
1	Valve Plug	AISI 316 SST (Hardfacing Available)	-20 — 600F (-29 — 315C)
2	*Valve Stem	AISI 316 Stainless Steel	-20 — 600F (-29 — 315C)
3	Piston Ring	Stellite [®]	-20 — 600F (-29 — 315C)
4	*Cage	AISI 410 Stainless Steel (w/ coating)	-20 — 600F (-29 — 315C)
5	*Seat Ring	AISI 316 SST (Hardfacing Available)	-20 — 600F (-29 — 315C)
6	¹ Load Ring	Inconel X750 [®]	-20 — 600F (-29 — 315C)
7	¹ Load Screws	300 Series Stainless Steel	-20 — 600F (-29 — 315C)
8	¹ Retaining Ring	AISI 302 Stainless Steel	-20 — 600F (-29 — 315C)
Unbalanced Plug Throttling			
1	Valve Plug	AISI 316 Stainless Steel	-20 — 600F (-29 — 315C)
5	Seat Ring	AISI 316 Stainless Steel	-20 — 600F (-29 — 315C)
Mini-P			
1	Valve Plug	17-4PH Stainless Steel	-20 — 600F (-29 — 315C)
5	Seat Ring	AISI 410 Stainless Steel	-20 — 600F (-29 — 315C)
Microtaper[®]			
1	Valve Plug	Stellite [®]	-20 — 600F (-29 — 315C)
Packing Modules (Standard & NACE)			
9	*Packing Follower	AISI 416 Stainless Steel	-20 — 1050F (-29 — 565C)
10	*Packing Flange	AISI 416 Stainless Steel	-20 — 1050F (-29 — 565C)
11	*Hex Nut	AISI 416 Stainless Steel	-20 — 1050F (-29 — 565C)
12	*Studs	ASTM A-193 B16	-20 — 1050F (-29 — 565C)
13	*Packing Set	BTG	-20 — 500F (-29 — 260C)
14	*Packing Set	Laminated Graphite	-20 — 1050F (-29 — 565C)
Body/Bonnet Modules (Standard & NACE)			
15	Hvy Hex Nut	ASTM A-194 Gr.7	-20 — 1050F (-29 — 565C)
15	Hvy Hex Nut(WCB Body)	ASTM A-194 Gr.2H	-20 — 800F (-29 — 427C)
16	Stud	ASTM A-193 Gr.B16	-20 — 1050F (-29 — 565C)
16	Stud (WCB Body)	ASTM A-193 Gr.B7	-20 — 800F (-29 — 427C)
17	*Gasket	Inconel [®] 600 Graphite	-20 — 1050F (-29 — 565C)
18	Body/Bonnet	ASTM A-216 Gr.WCB	-20 — 800F (-29 — 427C)
18	Body/Bonnet	ASTM A-351 Gr.CF8M	-20 — 1050F (-29 — 565C)
18	Body/Bonnet	ASTM A-217 Gr.WC9	-20 — 1050F (-29 — 565C)

* Included in all other trim modules unless otherwise listed

¹ Cage Guided 4" valve size only

INCONEL[®] is a trademark of the Inco Family of Companies
MICROTAPER[®] is a registered trademark of Leslie Controls, Inc.
NITRONIC 60[®] is a trademark of Armco, Inc.
STELLITE[®] is a trademark of Stoodly Deloro Stellite, Inc.

AEROFLOW HIGH PERFORMANCE CONTROL VALVES

**Packing Box Detail w/
BTG Packing**

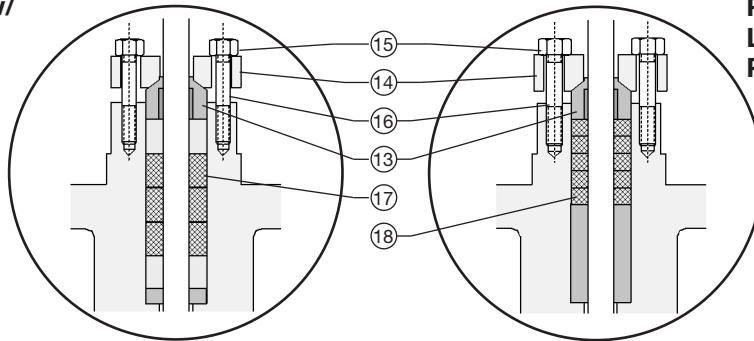

**Packing Box Detail w/
Laminated Graphite
Packing**

**Balanced
High-Temp
Trim**

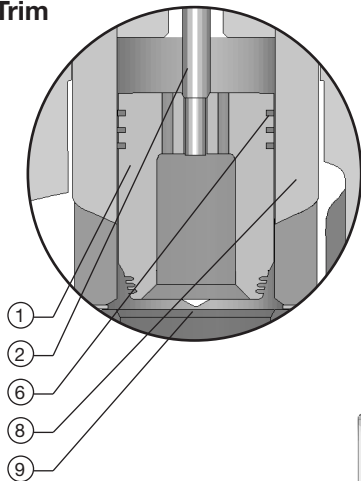

**Load Ring Detail
(4" Valve Sizes and Larger)**

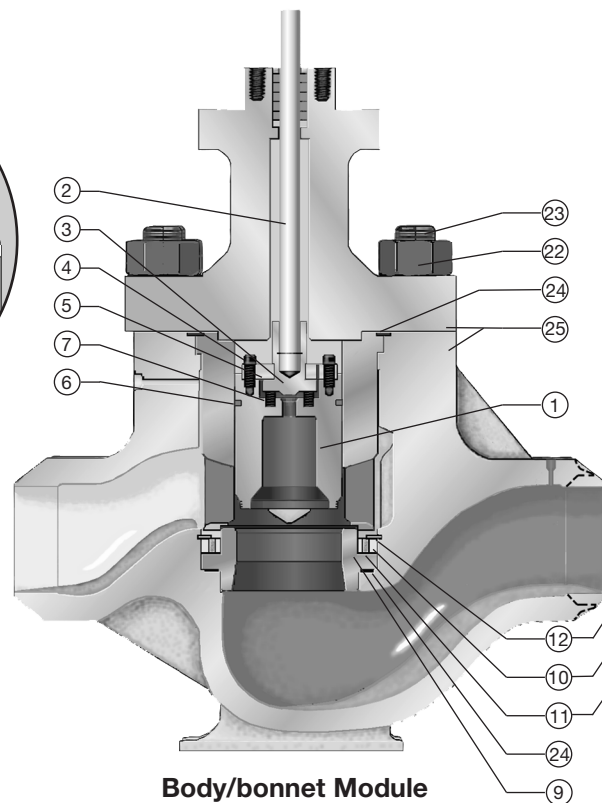
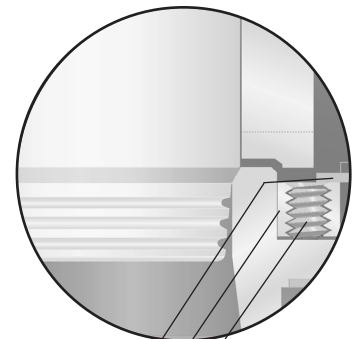

**Body/bonnet Module
shown with
Pilot Balanced Trim**

T² Trim

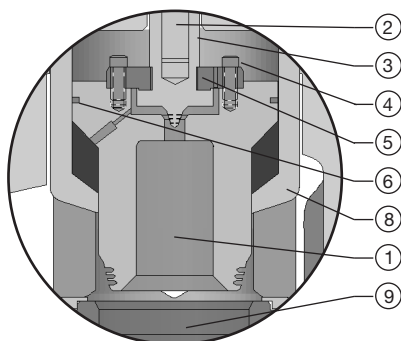

**Balanced
Low-Temp
Trim**

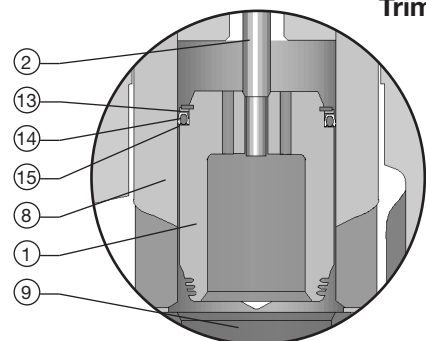

AEROFLOW HIGH PERFORMANCE CONTROL VALVES

Materials/Temperature Specifications

Trim Modules

No.	Description	Material Specification	Operational Temp. Range
Trim Modules - Standard Materials			
Pilot Balanced/T2/Balanced High-Temp			
1	*Valve Plug	AISI 420 Stainless Steel	-20 — 1050F (-29 — 565C)
2	*Valve Stem	Nitronic 60 [®]	-20 — 1050F (-29 — 565C)
3	Pilot Plug	AISI 431 Stainless Steel	-20 — 1050F (-29 — 565C)
4	Socket Head Cap Screw	AISI 18-8 Stainless Steel	-20 — 1050F (-29 — 565C)
5	Pilot Plate	AISI 416 Stainless Steel	-20 — 1050F (-29 — 565C)
6	*Piston Ring	Stellite [®]	-20 — 1050F (-29 — 565C)
7	Spring	Inconela [®]	-20 — 1050F (-29 — 565C)
8	*Cage	AISI 440 Stainless Steel	-20 — 800F (-29 — 427C)
8	*Cage	AISI 440 Stainless Steel (Malcolmized)	800 — 1050F (427 — 565C)
9	*Seat Ring	AISI 440 Stainless Steel	-20 — 1050F (-29 — 565C)
10	¹ Load Ring	AISI 410 Stainless Steel	-20 — 1050F (-29 — 565C)
11	¹ Load Screws	300 Series Stainless Steel	-20 — 1050F (-29 — 565C)
12	¹ Retaining Ring	AISI 302 Stainless Steel	-20 — 1050F (-29 — 565C)
Balanced Low Temp			
13	Retaining Ring	AISI 302 Stainless Steel	-20 — 1050F (-29 — 565C)
14	Seal Retainer	AISI 303	-20 — 1050F (-29 — 565C)
15	Seal	PTFE	-20 — 500F (-29 — 260C)
Trim Modules- NACE Materials			
Pilot Balanced/T2/Balanced High-Temp			
1	*Valve Plug	AISI 316 SSt. (Hardfacing Avail.)	-20 — 600F (-29 — 315C)
2	*Valve Stem	AISI 316 Stainless Steel	-20 — 600F (-29 — 315C)
3	Pilot Plug	AISI 316 Stainless Steel	-20 — 600F (-29 — 315C)
4	Socket Head Cap Screw	AISI 18-8 Stainless Steel	-20 — 600F (-29 — 315C)
5	Pilot Plate	AISI 316 Stainless Steel	-20 — 600F (-29 — 315C)
6	*Piston Ring	Stellite [®]	-20 — 600F (-29 — 315C)
7	Spring	Inconel [®]	-20 — 600F (-29 — 315C)
8	*Cage	AISI 410 SSt. w/ Coating	-20 — 600F (-29 — 315C)
9	*Seat Ring	AISI 316 Stainless Steel	-20 — 600F (-29 — 315C)
10	¹ Load Ring	Inconel X750 [®]	-20 — 600F (-29 — 315C)
11	¹ Load Screws	300 Series Stainless Steel	-20 — 600F (-29 — 315C)
12	¹ Retaining Ring	AISI 302 Stainless Steel	-20 — 600F (-29 — 315C)
Balanced Low Temp			
13	Retaining Ring	300 Series Stainless Steel	-20 — 600F (-29 — 315C)
14	Seal Retainer	300 Series Stainless Steel	-20 — 600F (-29 — 315C)
15	Seal	PTFE	-20 — 500F (-29 — 260C)
Packing Modules (Standard & NACE)			
16	*Packing Follower	AISI 416 Stainless Steel	-20 — 1050F (-29 — 565C)
17	*Packing Flange	AISI 416 Stainless Steel	-20 — 1050F (-29 — 565C)
18	*Hex Nut	AISI 416 Stainless Steel	-20 — 1050F (-29 — 565C)
19	*Studs	ASTM A-193 B16	-20 — 1050F (-29 — 565C)
20	*Packing Set	BTG	-20 — 500F (-29 — 260C)
21	*Packing Set	Laminated Graphite	-20 — 1050F (-29 — 565C)
Body/Bonnet Modules (Standard & NACE)			
22	Hvy Hex Nut	ASTM A-194 Gr.7	-20 — 1050F (-29 — 565C)
22	Hvy Hex Nut(WCB Body)	ASTM A-194 Gr.2H	-20 — 800F (-29 — 427C)
23	Stud 1 1/4-8	ASTM A-193 B16	-20 — 1050F (-29 — 565C)
23	Stud 1 1/4-8(WCB Body)	ASTM A-193 Gr.B7	-20 — 800F (-29 — 427C)
24	Gasket	Inconel [®] 600 Graphite	-20 — 1050F (-29 — 565C)
25	Body/Bonnet	ASTM A-216 Gr.WCB	-20 — 800F (-29 — 427C)
25	Body/Bonnet	ASTM A-351 Gr.CF8M	-20 — 1050F (-29 — 565C)
25	Body/Bonnet	ASTM A-217 Gr.WC9	-20 — 1050F (-29 — 565C)

* Common to all trim modules including Les-Cav/Les-Sonic unless otherwise listed

¹ 4" - 16" valve sizes only

² Malcolmized[®] in applications over 800°F (427°C)

INCONEL[®] is a trademark of the Inco Family of Companies

NITRONIC 60[®] is a trademark of Armco, Inc.

STELLITE[®] is a trademark of Stoodly Deloro Stellite, Inc.

AEROFLOW HIGH PERFORMANCE CONTROL VALVES

Flow Coefficients Globe vs. Angle

Flow Coefficients/Allowable ΔP for Aeroflow Anti-Cav Trim Configurations					
	Globe		Angle		Maximum Pressure Differential psi (bar)*
	FL	XT	FL	XT	
Unbalanced Plug Throttling (Flow under seat)	0.92	0.80	0.90	0.76	N/A
Unbalanced Plug Throttling (Flow over seat)**	0.75	0.50	0.65	0.40	N/A
Cage (UBC/LT/HT) Throttling (Flow under seat)	0.88	0.76	0.85	0.72	N/A
Cage (LT/HT/PB/T2) Throttling (Flow over seat)	0.85	0.72	0.83	0.70	N/A
Les-Sonic (Flow under seat)	N/A	0.68	N/A	0.64	N/A
Les-Sonic (Flow over seat)	N/A	0.66	N/A	0.62	N/A
Les-Cav I (Flow over seat)	0.94	N/A	0.92	N/A	400 (27.6)
Les-Cav II (Flow over seat)	0.96	N/A	0.94	N/A	750 (51.7)
Les-Cav III (Flow over seat)	0.98	N/A	0.96	N/A	2000 (138)
Les-Cav IV (Flow over seat)	0.99	N/A	0.97	N/A	3000 (207)
Les-Cav V (Flow over seat)	0.99	N/A	0.98	N/A	4000 (276)
MicroTaper [®] (Flow under seat)	0.92	0.80	0.90	0.78	N/A
MicroTaper [®] (Flow over seat)**	0.70	0.45	0.60	0.35	N/A
Mini-P (Flow under seat)	0.98	N/A	0.96	N/A	2000 (138)

* Other trim Configurations Maximum Pressure Differential will be limited on Allowable Liquid Velocities

** Consult factory for limitations of using unbalanced trim to flow over seat.

How to Specify Aeroflow Control Valves

Valve Body

- 1.1.1 Body should have integrally cast flow control vanes in the inlet, outlet and body gallery to reduce turbulence and allow maximum Cv/Size ratios.
- 1.1.2 Body should be designed with pressure taps on the inlet and outlet side so that adjacent piping penetration points are not needed.
- 1.1.3 Globe and angle body configurations should be designed so that trim modules are fully interchangeable.
- 1.1.4 High pressure body designs (900-2500#) should allow for machining to accept an outlet pipe nominally one size larger than the valve body size.

Valve Trim

- 1.2.1 Pilot balance trim to have capability to shutoff to ANSI Class VI or Zero (cc/min) Leakage utilizing metal-to-metal seats.
- 1.2.2 Valve plug should be designed with a three stage labyrinth style plug tip.
- 1.2.3 Trim design should allow for reduction down to a 0.2 factor of full Cv, without changing the original plug or seat ring
- 1.2.4 Cage design should allow for modification of flow window for a desired flow characteristic without reducing plug assembly.
- 1.2.5 Unbalanced designs should allow for reduction of Cv without reducing seat ring diameter.

Actuators

- 2.1.1 Actuator should be designed in a steel or composite construction that is rated for 150 psig working pressure.
- 2.1.2 Air failure spring should be mounted outside air cylinder to minimize residual air volume.
- 2.1.3 Spring cartridge should be mounted so that accessibility for reversing failure modes is easily accomplished.
- 2.1.4 Actuator/spring assembly shall be designed to provide a low center of gravity for areas of seismic activity.

Electro-Pneumatic Positioners

- 3.1.1 Positioner design should include as a standard: built in limit switch contacts and a 4-20mA position transmitter output.
- 3.1.2 Positioner should have a guaranteed accuracy of +0.0012" of calibrated span.
- 3.1.3 Positioner should have a guaranteed repeatability of +0.0012" of span.
- 3.1.4 Hysteresis including dead band should be 0.0%.
- 3.1.5 Positioner steady state air consumption should be 0.00 SCFM.

AEROFLOW HIGH PERFORMANCE CONTROL VALVES

Accessories

Leslie Magnum Series Actuators

Double Acting
Spring Return
Double Acting Spring Return

Electric & Electro-Hydraulic

Actuators
EIM, Rotork, Limitorque & Others
Rexa L & T Series

Pneumatic Positioners

Sigmens 760P
Bailey AV Series
PMV Series

Electropneumatic Positioners

Leslie DPS
(See Product Data Sheet
#1 0/0.2.5)
Moore 750E
Bailey AV Series
PMV Series

Controllers

PMC Electropneumatic - Press/Temp
(See Product Data Sheet #26/0.1.1)
Leslie PDAP/PRAP
(See Product Data Sheet #20/2.1.1)

Solenoid Valves

ASCO, Versa, and Others

Limit Switches

Namco, Westlock, Laurence & Others

Air Regulators

Leslie AFG-2 Airset
(See Product Data Sheet #30/1.1.1)
Leslie S-Transfer Valve
(See Product Data Sheet #20/7.2.1)
Lockup Valve

Additional Options

Other Body Materials
Other Trim Materials
Nace Compliance
Snubber Mechanism
Limit Stops
Volume Tank w/Trip System
Electropneumatic Transducers
Pipe Reducers & Expanders
Low Noise Plates
Hydraulic Overrides

Applicable Industry Standards

All Leslie control valves are 100% factory tested and serialized. Leslie Controls' quality assurance program is accredited and certified to ISO 9001*. All Leslie control valves are also designed, built and tested to meet the following industry standards.

ANSI B1.20.1 Pipe Threads - Conforms to pipe thread requirements.

ANSI B16.11 Socket Weld Ends - Conforms to socket weld end requirements.

ANSI B16.5 Pipe Flanges and Flanged Fittings - Conforms to flange thickness, diameter and drilling requirements.

ANSI B16.25 Butt-welding Ends - Conforms to requirements of all schedule pipe, without backing rings.

ANSI B16.34 Valves, Flanged and Butt-weld - Integral flanged valve conforms to wall thickness, materials, pressure/temperature ratings, markings, and hydrostatic test requirements.

ANSI B16.37 Hydrotesting of Control Valves - Conforms to hydrotesting requirements.

ANSI/ISA 70-2** Control Valve Seat Leakage - Conforms to Class II, III, IV, V, and VI shutoff requirements.

ISA S75.01 Flow Equations for Sizing Control Valves.

ISA S75.02 Control Valve Capacity Test Procedure - Conforms to flow capacity test procedure requirements.

ISA S75.12 Face-To-Face Dimensions for Socket-weld End and Screwed End Globe Style Control Valves - Conforms to face-to-face dimension requirements.

ISA S75.15 Face-To-Face Dimensions for Butt-weld End Globe Style Control Valves - Conforms to face-to-face dimension requirements.

MSS SP25 Standard Marking System for Valves, Fittings, and Unions - Conforms to marking requirements for flanged, screwed and weld end fittings.

MSS SP84 Steel Valves, Socket-weld End and Threaded End - Conforms to end connection requirements.

In addition, when required, Leslie control valves can be manufactured and supplied in compliance with:

CAN 3 Z299.3

ANSI N45.2

MIL-STD-45662

MIL-1-45208

ASME Sec.1

B 31.1

*Accredited and certified by ABS, Houston, Texas

**Formerly listed as B16.104

AEROFLOW HIGH PERFORMANCE CONTROL VALVES

Dimensions

Actuator Assembly

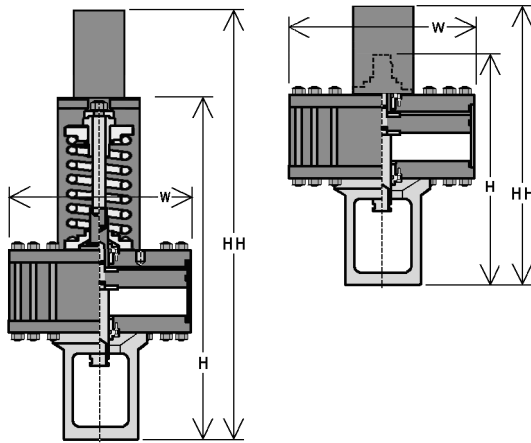

Body/Bonnet Assembly (see chart next page)

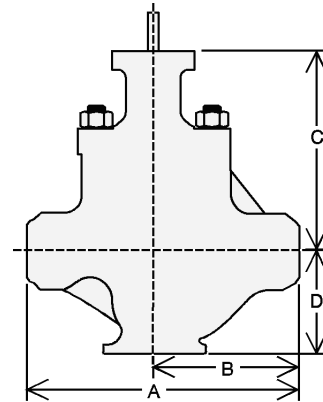

DOUBLE-ACTING Inches (mm)							
MODEL	H	HH	W	NOM. DIA.	NOM. AREA in ² (cm ²)	WGT.*	SHPG. VOL.* ft ³ (m ³)
P28DA	16 $\frac{3}{4}$ (425)	25 $\frac{1}{6}$ (659)	7 (178)	6 (152)	28 (181)	82 (37)	2.1 (0.06)
P80DA	17 $\frac{1}{2}$ (444)	26 $\frac{1}{6}$ (678)	10 $\frac{1}{2}$ (267)	10 (254)	78 (503)	132 (60)	3.7 (0.11)
P130DA	28 (711)	39 (991)	14 (356)	13 (330)	130 (839)	232 (105)	8.1 (0.23)
P200DA	24 $\frac{3}{4}$ (628)	35 $\frac{3}{4}$ (908)	16 $\frac{1}{2}$ (419)	16 (406)	201 (1297)	295 (134)	9.7 (0.27)
P300DA	24 $\frac{3}{4}$ (628)	35 $\frac{3}{4}$ (908)	20 $\frac{1}{2}$ (521)	20 (508)	314 (2026)	415 (193)	13.8 (0.39)

SPRING RETURN Inches (mm)							
MODEL	H	HH	W	NOM. DIA.	NOM. AREA in ² (cm ²)	WGT.*	SHPG. VOL.* ft ³ (m ³)
P28SR	27 $\frac{1}{4}$ (692)	36 $\frac{7}{6}$ (926)	7 (178)	6 (152)	28 (181)	122 (55)	2.8 (0.08)
P80SR	28 (711)	37 $\frac{7}{6}$ (945)	10 $\frac{1}{2}$ (267)	10 (254)	78 (503)	172 (78)	5 (0.14)
P130SR	48 (1219)	59 (1499)	14 (356)	13 (330)	130 (839)	352 (160)	11.8 (0.33)
P200SR	42 $\frac{1}{2}$ (1070)	53 $\frac{1}{8}$ (1349)	16 $\frac{1}{2}$ (419)	16 (406)	201 (1297)	425 (188)	14 (0.39)
P300SR	42 $\frac{1}{2}$ (1070)	53 $\frac{1}{8}$ (1349)	20 $\frac{1}{2}$ (521)	20 (508)	314 (2026)	535 (243)	20 (0.56)

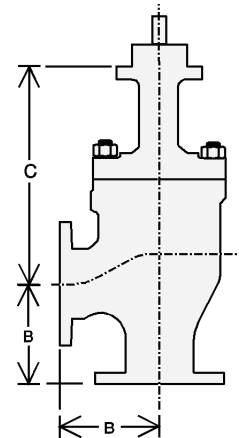

* values are approximate; includes manual override

AEROFLOW HIGH PERFORMANCE CONTROL VALVES

ANSI CLASS 900-2500 Dimensions

DIMENSIONS IN INCHES							Shpg. Info. ¹		DIMENSIONS IN MILLIMETERS					Shpg. Info. ¹	
SIZE	A	B	C ²	D	WGT.	VOL.	SIZE	A	B	C ²	D	WGT.	VOL.		
ANSI CLASS 900/1500 PN160-250 BWE/SWE							ANSI CLASS 900/1500 PN160-250 BWE/SWE								
1	11	5½	9½	3½	87 lb.	2 ft ³	25	279	140	241	79	39 kg	0.1 m ³		
1½	13	6½	9½	3½	125 lb.	3 ft ³	40	330	165	251	89	57 kg	0.1 m ³		
2	14¾	7½	12¾	4½	230 lb.	4 ft ³	50	400	200	323	379	104 kg	0.1 m ³		
3	18½	9½	14½	6½	346 lb.	7 ft ³	75	460	251	368	156	157 kg	0.2 m ³		
4 Gib	20¾	11½	15¾	7¾	484 lb.	10 ft ³	100	574	308	400	197	220 kg	0.3 m ³		
4 Angl	N/A	11½	15¾	7¾	484 lb.	10 ft ³	100	574	308	400	197	220 kg	0.3 m ³		
6	30¾	15¾	20¾	10½	1311 lb.	24 ft ³	150	819	384	527	259	595 kg	0.7 m ³		
8	32¾	16¾	23½	13¾	3069 lb.	34 ft ³	200	1022	416	598	337	1392 kg	1.0 m ³		
10	39	19½	28½	16½	3800 lb.	52 ft ³	250	991	495	724	419	1723 kg	1.5 m ³		
12	44½	22¾	30½	19¾	5700 lb.	74 ft ³	300	1130	565	775	502	2585 kg	2.1 m ³		
16	56	28	34½	26	8100 lb.	134 ft ³	400	1422	711	876	660	3674 kg	3.8 m ³		
ANSI CLASS 2500 PN400 BWE/SWE							ANSI CLASS 2500 PN400 BWE/SWE								
1	12½	6¾	9½	3½	90 lb.	3 ft ³	25	318	159	241	79	41 kg	0.1 m ³		
1½	14¾	7½	9½	3½	130 lb.	3 ft ³	40	359	191	251	89	59 kg	0.1 m ³		
2	15¾	7¾	12¾	4½	250 lb.	5 ft ³	50	375	187	323	379	113 kg	0.1 m ³		
3	19¾	9½	14½	6½	511 lb.	8 ft ³	75	460	230	368	156	232 kg	0.2 m ³		
4 Gib	22¾	12½	15¾	8	625 lb.	11 ft ³	100	530	301	400	203	283 kg	0.3 m ³		
4 Angl	N/A	11½	15¾	8	625 lb.	11 ft ³	100	530	301	400	203	283 kg	0.3 m ³		
6	32¾	16¾	20¾	11	1590 lb.	27 ft ³	150	768	409	527	280	721 kg	0.8 m ³		
8	40¾	20¾	23½	14¾	4059 lb.	51 ft ³	200	832	511	598	362	1841 kg	1.4 m ³		
10	50	25	28½	17½	4900 lb.	84 ft ³	250	1270	635	724	419	2223 kg	2.4 m ³		
12	56	28	30½	20¾	7100 lb.	115 ft ³	300	1422	711	775	502	3221 kg	3.3 m ³		
16	Call	Call	34½	27	10600 lb.	Call ft ³	400	Call	Call	876	660	4808 kg	Call		
ANSI CLASS 900 PN160 Flanged (RF and RTJ)							ANSI CLASS 900 PN160 Flanged (RF and RTJ)								
1	17¾	8¾	9½	3½	105 lb.	4 ft ³	25	438	219	241	79	48 kg	0.1 m ³		
1½	20	10	9½	3½	150 lb.	6 ft ³	40	508	254	251	89	68 kg	0.2 m ³		
2	23¾	11½	12¾	4½	280 lb.	9 ft ³	50	591	295	323	379	113 kg	0.3 m ³		
3	26¾	13½	14½	6½	551 lb.	13 ft ³	75	676	338	368	156	232 kg	0.4 m ³		
4 Gib	30¾	15½	15¾	8	680 lb.	18 ft ³	100	770	379	400	203	283 kg	0.5 m ³		
4 Angl	N/A	15½	15¾	8	680 lb.	Call ft ³	100	N/A	386	400	203	283 kg	Call		
6	41¾	20¾	20¾	11	1680 lb.	43 ft ³	150	1060	530	527	280	721 kg	1.2 m ³		
8	46¾	23½	23½	14¾	4189 lb.	78 ft ³	200	1172	586	598	362	1841 kg	1.9 m ³		
10	54	27	28½	17½	5070 lb.	106 ft ³	250	1372	686	724	419	2300 kg	2.8 m ³		
12	60¾	30¾	30½	20¾	7300 lb.	147 ft ³	300	1543	772	775	502	3311 kg	3.8 m ³		
16	73½	36¾	34½	27	10840 lb.	225 ft ³	400	1867	933	876	660	4917 kg	6.5 m ³		
ANSI CLASS 1500 PN250 Flanged (RF and RTJ)							ANSI CLASS 1500 PN250 Flanged (RF and RTJ)								
1	17¾	8¾	9½	3½	105 lb.	4 ft ³	25	438	219	241	79	48 kg	0.1 m ³		
1½	20	10	9½	3½	150 lb.	6 ft ³	40	508	254	251	89	68 kg	0.2 m ³		
2	23¾	11½	12¾	4½	280 lb.	9 ft ³	50	591	295	323	379	113 kg	0.3 m ³		
3	26¾	13½	14½	6½	561 lb.	14 ft ³	75	708	354	368	156	254 kg	0.4 m ³		
4 Gib	31¾	16½	15¾	8	690 lb.	19 ft ³	100	791	389	400	203	313 kg	0.5 m ³		
4 Angl	N/A	15½	15¾	8	690 lb.	Call	100	N/A	395	400	203	313 kg	Call		
6	44¾	22¾	20¾	11	1685 lb.	47 ft ³	150	1124	562	527	280	764 kg	1.4 m ³		
8	50¾	25¾	23½	14¾	4199 lb.	90 ft ³	200	1273	637	598	362	1905 kg	2.2 m ³		
10	59¾	29¾	28½	17½	5100 lb.	126 ft ³	250	1511	756	724	419	2313 kg	3.3 m ³		
12	67¾	33¾	30½	20¾	7360 lb.	176 ft ³	300	1708	854	775	502	3338 kg	4.6 m ³		
16	81	40¾	34½	27	10980 lb.	271 ft ³	400	2057	1029	876	660	4980 kg	7.7 m ³		
ANSI CLASS 2500 PN400 Flanged (RF and RTJ)							ANSI CLASS 2500 PN400 Flanged (RF and RTJ)								
1	20	10	9½	3½	110 lb.	6 ft ³	25	508	254	241	79	50 kg	0.2 m ³		
1½	23¾	11½	9½	3½	160 lb.	8 ft ³	40	594	297	251	89	73 kg	0.2 m ³		
2	26¾	13½	12¾	4½	290 lb.	12 ft ³	50	667	333	323	379	113 kg	0.3 m ³		
3	33¾	16½	14½	6½	576 lb.	27 ft ³	75	848	424	368	156	232 kg	0.6 m ³		
4 Gib	38¾	19½	15¾	8	710 lb.	37 ft ³	100	968	562	400	203	283 kg	0.8 m ³		
4 Angl	N/A	19½	15¾	8	710 lb.	Call	100	N/A	484	400	203	283 kg	Call		
6	54¾	27¾	20¾	11	1745 lb.	73 ft ³	150	1378	689	527	280	721 kg	2.0 m ³		
8	65¾	32¾	23½	14¾	4249 lb.	124 ft ³	200	1670	829	598	362	1841 kg	3.6 m ³		
10	83½	41¾	28½	17½	5180 lb.	240 ft ³	250	2121	1060	724	419	2350 kg	6.2 m ³		
12	93	46¾	30½	20¾	7460 lb.	336 ft ³	300	2362	1181	775	502	3384 kg	8.5 m ³		
16	C/F	C/F	34½	27	11120 lb.	C/F	400	C/F	C/F	876	660	5044 kg	C/F		

NOTE: DIMENSIONS ARE SUBJECT TO CHANGE WITHOUT NOTICE. Request certified drawings for piping layout and construction purposes.

¹ Approximate weight and volume
² Consult factory for extended travel (C dimension)

AEROFLOW HIGH PERFORMANCE CONTROL VALVES

ACCESSORIES

Moore Series 760 Positioners

- Pneumatic: Model 760P
- Electropneumatic: Model 760E
- Digital: Model 760D
- Optional internal limit switches
- Optional valve position transmission

Other Positioners

- PMV Series 1200, 2000 and P5
- Hartmann & Braun/Sensycon TZID
- SMAR FY302 Fieldbus
- Siemens PS2
- Bailey AV Series

Process Controllers

- Electropneumatic: Leslie PMC-2
- Pneumatic: Leslie PDAP/PRAP

Solenoid Valves

- ASCO 8320G174 is standard
- Other Asco models, Versa, Skinner, as required

Electric Actuators

- Jordan

Electrohydraulic Actuators

- Rexa L & T Series

Limit Switches

- Westlock
- National Acme (NAMCO)
- Honeywell (Micro)
- GO Proximity Switches

Noise Reduction Devices

- Leslie Noise Suppressor
- Leslie Les-Sonic Silencing Orifice

Air Regulators

- Leslie AFG-2
- Bellofram Type 50
- Control Air Type 300

Other Options

- Handwheels
- Hydraulic Manual Override System
- Limit Stops
- Special Connections
 - Socketweld
 - Butt weld
 - Stub Ends
 - Pipe Reducers
 - Smooth Flange Faces
 - Ring Type Joints

Instruments

- Lockup Valves
- Leslie S-Transfer Valve

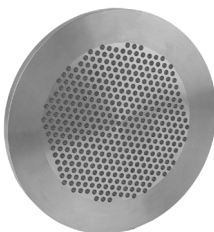
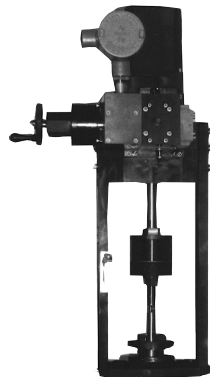
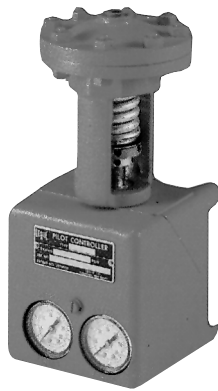

Specification form for Measurement and Control Instruments, Primary Elements and Control Valves

 <p>LESLIE CONTROLS, INC.</p> <p>A subsidiary of CIRCOR International, Inc.</p> <p>12501 Telecom Drive • Tampa, Florida 33637 (813) 978-1000 • FAX: (813) 977-0174</p>	Project/Job _____ Unit/Customer _____ P.O./LCO File # _____ Item _____ Contract _____ MFR Serial# _____	Data Sheet ____ of ____ Spec _____ Tag _____ Dwg _____ Service _____
--	--	--

1	Fluid	<input type="checkbox"/> Steam <input type="checkbox"/> Water <input type="checkbox"/> Gases <input type="checkbox"/> Liquid	Crit Pres	PC			
2	S	Flow	<input type="checkbox"/> #/hr <input type="checkbox"/> gpm <input type="checkbox"/> scfh	Max. Flow	Norm. Flow	Min. Flow	Shut-off
	E		<input type="checkbox"/> kg/hr. <input type="checkbox"/> <input type="checkbox"/> m ³ /hr <input type="checkbox"/>				--
3	R	Inlet Press.	<input type="checkbox"/> psig <input type="checkbox"/> psia <input type="checkbox"/> kg/cm ² <input type="checkbox"/>				psig
4	V	Outlet Press.	<input type="checkbox"/> psig <input type="checkbox"/> psia <input type="checkbox"/> kg/cm ² <input type="checkbox"/>				psig
5	I	Temperature	<input type="checkbox"/> °C <input type="checkbox"/> °F				
6	C	Spec. Wt./Spec. Grav./Mol. Wgt.					
7	E	Viscosity/Spec. Heats Ratio					--
8		Vapor Pressure Pv	<input type="checkbox"/> psia <input type="checkbox"/>				--
9	C	*Required Cv					--
10	O	*Travel %					--
11	N	Allowable/*Predicted SPL (dBA)					0
12	D	FL _____	X _T _____				

13	L	Pipe Size/Sch. In _____ /Sch _____	49	A	*Type	<input type="checkbox"/> DA <input type="checkbox"/> SR <input type="checkbox"/> DASR <input type="checkbox"/> Diaph <input type="checkbox"/> EHA <input type="checkbox"/> Electr. <input type="checkbox"/> Other	
14	I	Pipe Size/Sch. Out _____ /Sch _____					
15	N	Pipe Line Insulation _____ in.	50		*Mfr./Model _____ / _____		
16	VALVE BODY AND BONNET	Type	51	ACTUATOR	*Size/Eff Area	<input type="checkbox"/> 6"/28 in ² <input type="checkbox"/> 10"/80 in ² <input type="checkbox"/> 13"/130 in ² <input type="checkbox"/> 16"/200 in ² <input type="checkbox"/> 20"/300 in ² <input type="checkbox"/> Other	
17		*Body Size in.	<input type="checkbox"/> 1 <input type="checkbox"/> 1 1/2 <input type="checkbox"/> 2 <input type="checkbox"/> 3 <input type="checkbox"/> 4 <input type="checkbox"/> 6 <input type="checkbox"/> 8 <input type="checkbox"/> 10 <input type="checkbox"/> 12 <input type="checkbox"/> 16 <input type="checkbox"/> _____		52	<input type="checkbox"/> On/Off <input type="checkbox"/> Modulating	
		ANSI Class	<input type="checkbox"/> 150 <input type="checkbox"/> 300 <input type="checkbox"/> 600 <input type="checkbox"/> _____ <input type="checkbox"/> 900 <input type="checkbox"/> 1500 <input type="checkbox"/> 2500 <input type="checkbox"/> 4500		53	Spring Action/Air Failure	<input type="checkbox"/> Open <input type="checkbox"/> Closed <input type="checkbox"/> None Spring # _____
18		Design. Press. Temp	_____ / _____		54	*Max. Allowable Press.	_____
19		Mfr./Model:	Leslie/Aeroflow		55	*Min. Required Press.	_____ psig
20		Body/Bonnet Mat'l	<input type="checkbox"/> WCB <input type="checkbox"/> WC9 <input type="checkbox"/> CF8M <input type="checkbox"/> C5 <input type="checkbox"/> WC6 <input type="checkbox"/> _____		56	Available Air Supply Press.	_____
21		End Conn Inlet/Outlet	<input type="checkbox"/> Flg RF <input type="checkbox"/> Thd <input type="checkbox"/> RTJ <input type="checkbox"/> SWE <input type="checkbox"/> BWE/Sch <input type="checkbox"/> In BWE/Sch <input type="checkbox"/> In SWE <input type="checkbox"/> Out BWE/Sch <input type="checkbox"/> Out SWE <input type="checkbox"/> In Stubs/Sch Length (in.) _____ <input type="checkbox"/> Out Stub/Sch Length (in.) _____ <input type="checkbox"/> Exp _____ x _____ In/Sch _____ <input type="checkbox"/> Exp _____ x _____ Out/Sch _____		57	*Bench Range	_____ psig <input type="checkbox"/> N/A
22		Fig. Face Finish	RMS <input type="checkbox"/> Std. (125-500)		58	Act. Orientation	<input type="checkbox"/> Horiz. <input type="checkbox"/> Vert. Override Type <input type="checkbox"/> Manual Hyd. <input type="checkbox"/> None
23		End Ext/Mat'l.	_____		59	Air Failure Valve	<input type="checkbox"/> Opens <input type="checkbox"/> Closes <input type="checkbox"/> Last Tubing <input type="checkbox"/> SST <input type="checkbox"/> Copper <input type="checkbox"/> 3/8" <input type="checkbox"/> 1/2" <input type="checkbox"/> _____
24		*Flow	<input type="checkbox"/> Over <input type="checkbox"/> Under Seat		60	Data Tag:	<input type="checkbox"/> Brass <input type="checkbox"/> SST Solenoid: <input type="checkbox"/> Asco/8320G174 <input type="checkbox"/> None <input type="checkbox"/> Other Mfr./Model _____ / _____
25	*Type Bonnet	<input type="checkbox"/> Std <input type="checkbox"/> Ext Lub & Isol Valve <input type="checkbox"/> Yes <input type="checkbox"/> No Lube <input type="checkbox"/> Yes <input type="checkbox"/> No *Packing Mat'l <input type="checkbox"/> LG <input type="checkbox"/> BTG <input type="checkbox"/> DTFE <input type="checkbox"/> _____	61	Input Signal	<input type="checkbox"/> 3-15 psi <input type="checkbox"/> 4-20 mA <input type="checkbox"/> _____ *Type <input type="checkbox"/> Pneu. (750P) <input type="checkbox"/> I/P(750E) <input type="checkbox"/> DPS <input type="checkbox"/> None <input type="checkbox"/> Other *Mfr./Model _____ / _____		
26			62	*On Incr. Signal Output	<input type="checkbox"/> Incr. <input type="checkbox"/> Decr. Gauges <input type="checkbox"/> Yes <input type="checkbox"/> No, <input type="checkbox"/> By-Pass <input type="checkbox"/> Yes <input type="checkbox"/> No *Cam Charact. <input type="checkbox"/> Linear <input type="checkbox"/> =% <input type="checkbox"/> Sq.Root		
27			63	*Type	<input type="checkbox"/> Mech (Namco EA170-1100) <input type="checkbox"/> None <input type="checkbox"/> Other *Mfr./Model _____ / _____		
28			64	Contacts/Rating	<input type="checkbox"/> Other <input type="checkbox"/> SPDT <input type="checkbox"/> DPDT Actuation points: <input type="checkbox"/> Both <input type="checkbox"/> Open <input type="checkbox"/> Closed NEMA Class 1,4, &13		
29			65	*Mfr./Model:	Leslie/ <input type="checkbox"/> AFG-2 <input type="checkbox"/> None		
30			66	*Set Press.	_____ PSIG <input type="checkbox"/> _____ / _____		
31			67	Filter	<input type="checkbox"/> Yes <input type="checkbox"/> No, <input type="checkbox"/> Gauge <input type="checkbox"/> Yes <input type="checkbox"/> No Range: <input type="checkbox"/> 3-60 psi <input type="checkbox"/> 30-150psi <input type="checkbox"/> _____		
32			68	*Hydro Pressure	_____		
33			69	ANSI/FCI Leakage Class	<input type="checkbox"/> III <input type="checkbox"/> IV <input type="checkbox"/> V <input type="checkbox"/> VI <input type="checkbox"/> Zero CC/min		
34			70	No Service Cond. Available	<input type="checkbox"/>		
35			71	Attached Cv Calcs	<input type="checkbox"/> Yes <input type="checkbox"/> No		
36			72	Special Factory Instr. Attached	<input type="checkbox"/> Yes <input type="checkbox"/> No		
37			73	Shipping Schedule:	_____ weeks ARO		
38			74	SRI#	_____ Date _____		
39			75	Approx. Weight	_____ lbs. each		
40			76	Qty.	_____ Approx. Weight _____ lbs. Total		
41			77	Unit Net Price \$	_____ each		
42			78	Extension Net Price \$	_____ Total		
43			79	Leslie Quote #	_____		
44			80	Rev.	_____		
45			81	Date	_____		
46			82	Revision	_____		
47			83	Orig	_____		
48			84	App	_____		



NOTES:



NOTES:



NOTES:

Commitment to Excellence



Fabrication, Service & Repair

Remanufacturing, Testing, Preventative Maintenance, Customer Training and Fabrication

Circor International operates three service centers (New Jersey, Virginia and Florida) where valves of many major manufacturers are returned to original factory specifications and given a new service warranty at a fraction of the original purchase cost. We also have an international network of Leslie licensed and trained "Red Seal" Service Centers capable of performing the same quality of work as our service centers.

Circor Service Centers are also authorized to service valves manufactured by K&M, R.G. Laurence, CPC-Cryolab, Spence Engineering, Nicholson, KF, Circle Seal, SSI Equipment, Hoke, Aerodyne Controls, SKVC, Watts ACV, Go Regulator, Pibiviesse, Telford, Chas. M. Bailey, and Contromatics.

In addition to handling factory repairs, each Service Center has available factory trained Field Service Technicians to provide

on-site repairs and preventative maintenance where removal is impractical or extended shutdown is unacceptable. Circor Service Centers also provide custom tailored, in-depth, hands-on training programs in operation, instrumentation and maintenance of all supported equipment. Training is conducted at one of our specially designed, fully equipped repair facilities or at your location using your own equipment.

Another service provided at the Circor Service Centers is panel board fabrication. Whenever it is not practical to assemble components on-site, our experts can design, build, and ship or deliver and install a unit customized to suit your needs.

Service is a fundamental part of the Leslie operating philosophy and we urge you to request additional documentation and descriptive material.

* Assessed and certified by ABS Quality Evaluations, Inc., Houston, Texas

Since LESLIE CONTROLS was founded in 1900, we have been an industry leader in quality fluid control equipment. We have developed a full line of engineered products to suit your requirements, including diaphragm control valves, control instrumentation, pressure and temperature regulators and steam water heaters.



LESLIE
CONTROLS, INC.

A subsidiary of CIRCOR International, Inc.

12501 Telecom Drive
Tampa, FL 33637-0906

www.lesliecontrols.com

(813) 978-1000 • FAX: (813) 977-0174