

ANSI 150-600 CLASS DIN PN16-PN100

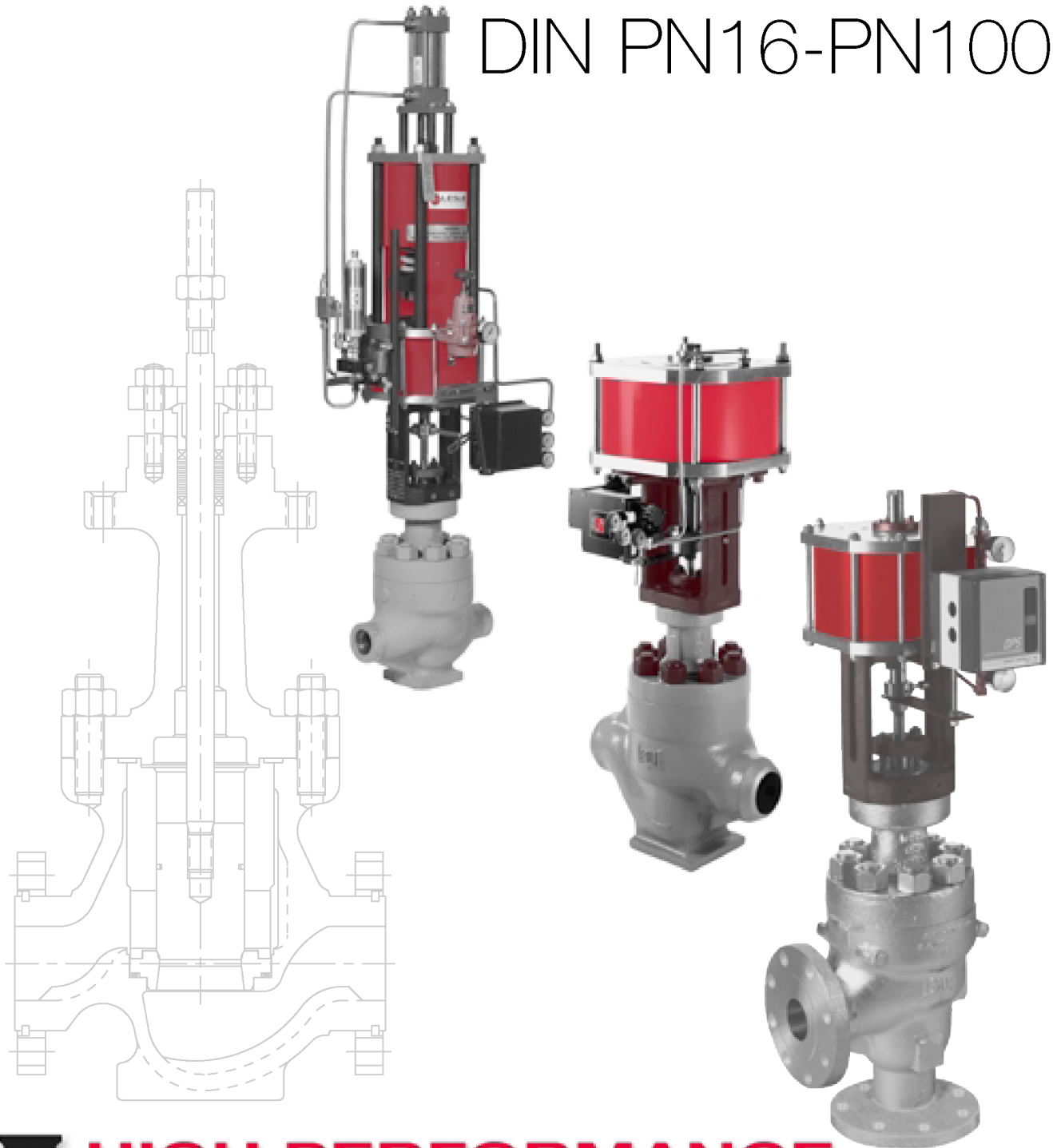

HIGH PERFORMANCE AEROFLOW CONTROL VALVES

LESLIE
CONTROLS, INC.

A subsidiary of CIRCOR International, Inc.

AEROFLOW

HIGH PERFORMANCE CONTROL VALVES ANSI 150-600 CLASS



LESLIE
CONTROLS, INC.

A subsidiary of **CIRCOR** International, Inc.

12501 Telecom Drive • Tampa, FL 33637-0906
Ph: (813) 978-1000 • Fax: (813) 977-0174

AEROFLOW HIGH PERFORMANCE CONTROL VALVES

Solution-Engineered Features for Demanding Applications

1. Aerodynamic Flow Control Valves

Integrally cast into the Inlet and Outlet

- Profiles flow to reduce turbulence
- Evenly distributes flow around the cage
- Reduces Noise generated in the valve

2. Zero Leakage Tight Shut-off

- Exceeds ANSI Class VI Shut-Off
- Metal to Metal Seat and Pilot Balanced Plug Design
- Zero cc/min without over Sized Actuators

3. Custom Characterized Trim Options

- C3 Combination Characterized Cage – Combines High Rangeability, Cavitation I Protection and Low Noise in One Valve
- T2 High Gain Trim – Ultra High Speed, Extraordinary Accuracy Guaranteed Repeatability
- Mini P Multi Stage Trim – Designed For Low-Flow, High ΔP , Cavitating Service with Tight Shut-Off
- Les-Sonic Cage – Provide up to a 25 BA noise reduction
- Les-CAV Multi Stage Cage – Up to five stages control for pressure drops to 4000 PSI (276 BAR)
- Micro Taper Trim – Specially designed trim for very fine control in Low-Flow/ High ΔP Applications

4. Tri-Shear Protected Seat Design

- Prevents high velocity erosion at opening and closing
- Provides a five-stage pressure drop near the seating position
- Prevents particle imp nement on the seating surfaces since they are withdrawn from the direct flow path before flow commences

5. “Smart Valve” Capability –

- Optional Inlet and Outlet pressure taps provide accurate, stable pressure measurements required by today’s “smart” instrument-action

6. Quick Change Trim Design (ANSI 900 and above)

- Seat retention and gasket loading are designed of reliability and ease of maintenance

7. Oversized Outlet Connection –

- Aeroflow Valves can be supplied with a larger outlet connection than the valve body size (Socketweld and Buttweld ends only)

8. Parts Interchangeability

- All parts interchangeable between globe and angle style bodies
- Reduces parts inventory
- Reduces maintenance training

AEROFLOW HIGH PERFORMANCE CONTROL VALVES

LESLIE CONTROLS

T²/DPS SYSTEM

SPEED	—	.5 SECOND OPERATION
ACCURACY	—	± .001"
REPEATABILITY	—	± .001"
ZERO LEAKAGE	—	0.00 CC/MIN AT RATED ϕP

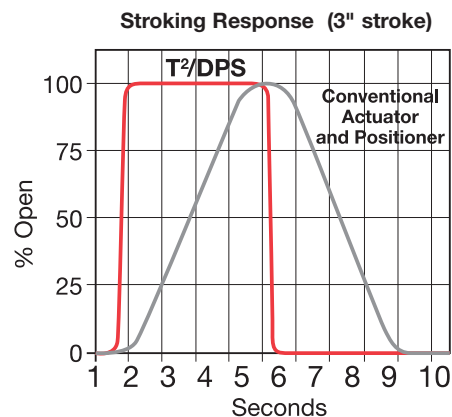

Finally a valve design that allows you to take full advantage of today's Smart Positioner Technology.

Three Components make up the T²/DPS System:

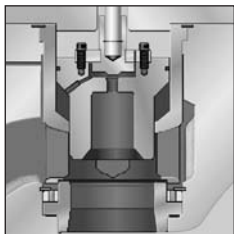

- **T² (Trim in Trim) High Gain Balanced Trim Pilot Trim** that uses fluid pressure to assist in opening/closing the valve plug in milliseconds



- **Optical/Digital Electro-Pneumatic Positioner Ultra-Fast** stable response using a plus Modulated output and an optical/digital non-mechanical stem position feedback



- **Leslie's Low Volume Cylinder Actuators** Low Air volume requirements translates into extremely fast speed of response

AEROFLOW HIGH PERFORMANCE CONTROL VALVES

MODULAR TRIM

Aeroflow trim design allows you to choose the ideal cost/performance combination for each application. All trim modules are 100% field interchangeable providing extraordinary flexibility and value. Any of the cage throttling designs shown below can be combined with any of the characterized cages shown in this section to give you the best possible solution to your specific flow control application. In addition, as shown at the bottom of this page, we can also offer customized trim sets for specific severe service applications where fine control of low flows and high differential pressures is a critical part to your operation.

CAGE THROTTLING DESIGNS

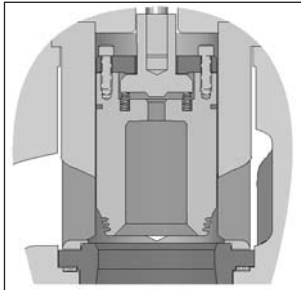
PILOT BALANCED (PB)

-20°F — 1050°F
-29°C — 565°C
Class IV/V/VI/Zero

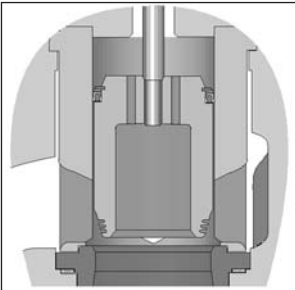
BAL. LOW-TEMP (BL)

-20°F — 500°F
-29°C — 260°C
Class IV/V

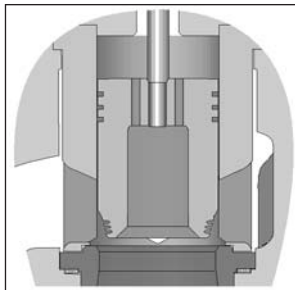
BAL. HIGH-TEMP (BH)

-20°F — 1050°F
-29°C — 565°C
Class III

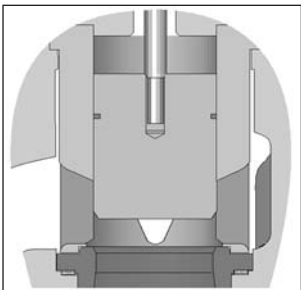
UNBALANCED (UBC)

-20°F — 1050°F
-29°C — 565°C
Class IV/V/VI/Zero

CUSTOM CHARACTERIZED CONTROL

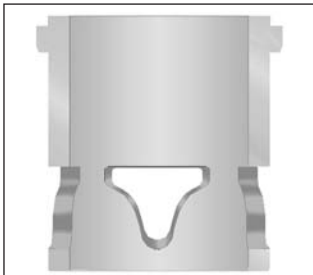
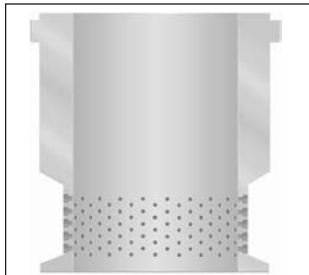
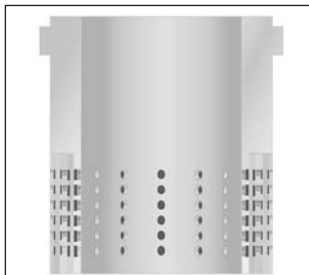
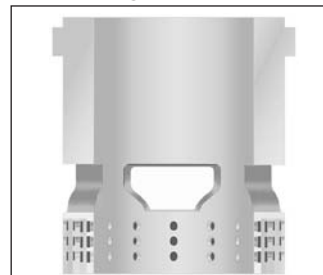
Standard Cage

**LesSonic Cage
Noise Control**

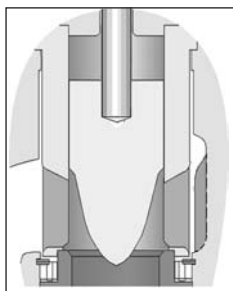
**LesCav V Cage
Cavitation Control**

**C³ Cage
Rauge Control**

CUSTOM TRIM SET OPTIONS

UNBALANCED (UBP)

-20°F — 1050°F
-29°C — 565°C
Class IV/V/VI/Zero

MICROTAPER® (MT)

For Fine Control on
Low Flow/
High ΔP Service

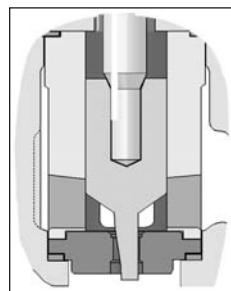

-20°F — 1050°F
-29°C — 565°C
Class IV/V/VI/Zero

MINI-P

For Staged Low Flow/
High ΔP Cavitating
Service

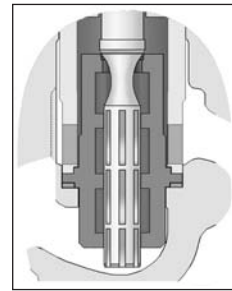

-20°F — 800°F
-29°C — 427°C
Class IV/V/Zero

AEROFLOW HIGH PERFORMANCE CONTROL VALVES

UNBALANCED PLUG THROTTLING (UBP) Cv Table ANSI Class 150 – 600

Linear and Equal %					
Valve Size in/DN	Stroke in/mm	Stem Dia. in/mm	Seat Dia. in/mm	Min Cv STD/DPS ¹	Max CV
1 / 25	1 / 25	0.75 / 20	1.00 / 25	0.20/0.06	16
1.5 / 40	1 / 25	0.75 / 20	1.50 / 40	0.20/0.10	30
2 / 50	1.5 / 40	0.75 / 20	2.25 / 57	0.30/0.10	57
3 / 80	2 / 50	0.75 / 20	3.00 / 80	0.40/0.20	120

Note: Minimum, Intermediate, and Maximum Cv's are shown for reference. Custom Cv's are standard.

¹ Minimum controllable Cv's are based on use of standard pneumatic positioner(STD) or Leslie Digital Positioning System (DPS).

CAGE THROTTLING (UBC, BL, BH, PB) Cv Table ANSI Class 150 – 600

Flow Characteristic						
Valve Size in/DN	Stroke in/mm	Stem Dia. ² in/mm	Seat Dia. in/mm	Min Cv STD/DPS ¹	LINEAR	EQUAL %
					MAX. Cv	MAX. Cv
					ANSI 150-600	ANSI 150-600
2 / 50	1.5 / 38	0.75 / 20	2.21/56	0.6/0.2	65	55
3 / 80	2 / 51	0.75 / 20	2.96/75	0.8/0.3	140	125
4 / 100	2 / 51	0.75 / 20	3.80/97	0.9/0.4	210	190
6 / 150	3 / 76	1.00 / 25	5.31/135	1.4/0.6	470	420
8 / 200	3/76 4 / 102	1.25 / 32	7.06/179	1.8/0.7 830	725 750	650 720
10 / 250	3 / 76 4 / 102	1.25 / 32	8.5/216	5.0/2.0	1375 1550	1230 1390
12 / 300	3 / 76 4 / 102	1.25 / 32	10/254	6.0/2.6	1740 2020	1560 1790
14 / 350	3 / 76 4 / 102	1.25 / 32	11.86/301	7.5/3.7	* *	* *
16 / 400	3 / 76 4 / 102	1.25 / 32	12.5/318	7.5/3.7	2500 3100	2250 2750

Note: Standard travel maximum, 0.6 and 0.2 factor Cv's are shown for reference in 2-6" valve sizes. Standard travel maximum and 0.6 Cv's are shown for reference in 8-16" valves sizes. Maximum Cv's shown for extended travel. **Custom Cv's are standard.**

¹ Minimum controllable Cv's are based on use of standard pneumatic positioner (STD or Leslie Digital Positioning System (DPS)).

² Stem diameter for T² trim is 1/2" for 2-6" sizes and 3/4" for 8" sizes.

* Consult Factory

AEROFLOW HIGH PERFORMANCE CONTROL VALVES

LES-SONIC CAGE THROTTLING Cv Table

Flow Characteristic - LINEAR							
Valve Size in/DN	Stroke in/mm	Stem Dia. ¹ in/mm	Seat Dia. in/mm	Min Cv	P/P1		
					≤ 0.6	>0.6 ≤ 0.8	>0.8 ≤ 0.99
					150-600	150-600	150-600
2 / 50	1.5 / 38 2 / 51	0.75 / 20	2.21 / 56	0.60	45	30	17
					60	40	23
3 / 80	2 / 51 3 / 76	0.75 / 20	2.96 / 75	0.80	100	55	30
					150	82	45
4 / 100	2 / 51 3 / 76	0.75 / 20	3.80 / 97	0.90	150	75	40
					225	110	60
6 / 150	3 / 76 4 / 102	1.00 / 25	5.31 / 135	1.40	330	150	85
					440	200	115
8 / 200	3 / 76 4 / 102 5 / 127	1.25 / 32	7.06 / 179	1.80	430	200	110
					525	265	150
					720	330	180
10 / 250	3 / 76 4 / 102 5 / 127	1.25 / 32	8.5 / 216	5.02	535	240	135
					720	320	180
					890	400	225
12 / 300	3 / 76 4 / 102 5 / 127	1.25 / 32	10 / 254	6.00	620	280	160
					830	375	210
					1030	470	270
14 / 350	3 / 76 4 / 102 5 / 127	1.25 / 32	11.86 / 301	7.50	760	340	190
					1010	450	250
					1270	570	315
16 / 400	3 / 76 4 / 102 5 / 127	1.25 / 32	12.5 / 318	7.50	920	410	230
					1230	550	310
					1540	690	390

¹ Stem diameter for T² trim is 1/2" for 2-6" sizes and 3/4" for 8" size.

LES-CAV CAGE THROTTLING (Single - Stage) Cv Table

Flow Characteristic - LINEAR									
Valve Size in/DN	Stroke in/mm	Stem Dia. ¹ in/mm	Seat Dia. in/mm	Min Cv STD/DPS ¹	ANSI 150-600				
					CAV I	CAV II	CAV III	CAV IV	CAV V
2 / 50	1.5 / 38 2 / 51	0.75 / 20	2.2 / 56	0.6	40	15	9	3.6	2.4
					52	20	12	7	6
3 / 80	2 / 51 3 / 76	0.75 / 20	2.96/75	0.8	75	28	18	6	4.8
					110	48	28	14	12
4 / 100	2 / 51 3 / 76	0.75 / 20	3.80/93	0.9	95	45	27	10.8	7.8
					140	76	46	26	22
6 / 150	3 / 76 4 / 102	1 / 25	5.31/135	1.4	200	110	58	22.8	16.8
					265	175	90	60	52
8 / 200	3 / 76 4 / 102 5 / 127	1.25 / 32	7.06/179	1.8	270	150	106	58	50
					340	225	140	87	75
					430	300	180	116	100
10 / 250	3 / 76 4 / 102 5 / 127	1.25 / 32	8.50/216	5.0	370	210	150	81	70
					490	280	195	122	106
					620	350	250	162	140
12 / 300	3 / 76 4 / 102 5 / 127	1.25 / 32	10/254	5.6	450	250	178	97	84
					600	330	235	146	126
					750	415	300	195	168
4 / 350	3 / 76 4 / 102 5 / 127	1.25 / 32	11.86 / 301	6.6	*	*	*	*	*
					*	*	*	*	*
					*	*	*	*	*
16 / 400	3 / 76 4 / 102 5 / 127	1.25 / 32	12.5/318	6.9	550	310	220	120	104
					730	410	290	180	150
					910	515	370	240	200

Note: Standard travel maximum and 0.6 factor Cv's are shown in 2-6" valve size for reference. Maximum Cv's are shown otherwise. **Custom Cv's are standard.**

¹ Stem diameter for T² trim is 1/2" for 2-6" sizes and 3/4" for 8" sizes.

* Consult Factory

AEROFLOW HIGH PERFORMANCE CONTROL VALVES

Mini-P (3-STAGE) PLUG THROTTLING Cv Table

Flow Characteristic - LINEAR					
Valve Size	Stroke	Stem Dia.	Seat Dia.	Min Cv	Max Cv
in/DN	in/mm	in/mm	in/mm		
1/25 or 1.5/40	0.75/20	0.75/20	0.375/22	0.08	1.2 3 5

MICROTAPER® PLUG THROTTLING Cv Table

Flow Characteristic - LINEAR					
Valve Size	Stroke	Stem Dia.	Seat Dia.	Min Cv	Max Cv
in/DN	in/mm	in/mm	in/mm		
1/25 or 1.5/40	0.75/20	0.75/20	0.375/9.5	0.01	0.3
			0.375/9.5	0.01	0.6
			0.375/9.5	0.01	1.2
			0.50/13	0.013	2.1
			.75/19	0.02	4.8
			1.0/25	0.03	8.5

Flow Coefficients Globe vs. Angle

Flow Coefficients/Allowable ΔP for Aeroflow Anti-Cav Trim Configurations						
	Globe		Angle		Maximum Pressure Differential psi (bar)*	
	FL	XT	FL	XT		
Unbalanced Plug Throttling (Flow under seat)	0.92	0.80	0.90	0.76	N/A	
Unbalanced Plug Throttling (Flow over seat)	0.75	0.50	0.65	0.40	N/A	
Cage (UBC/LT/HT) Throttling (Flow under seat)	0.88	0.76	0.85	0.72	N/A	
Cage (LT/HT/PB/T2) Throttling (Flow over seat)	0.85	0.72	0.83	0.70	N/A	
Les-Sonic (Flow under seat)	N/A	0.68	N/A	0.64	N/A	
Les-Sonic (Flow over seat)	N/A	0.66	N/A	0.62	N/A	
Les-Cav I (Flow over seat)	0.94	N/A	0.92	N/A	400 (27.6)	
Les-Cav II (Flow over seat)	0.96	N/A	0.94	N/A	750 (51.7)	
Les-Cav III (Flow over seat)	0.98	N/A	0.96	N/A	2000 (138)	
Les-Cav IV (Flow over seat)	0.99	N/A	0.97	N/A	3000 (207)	
Les-Cav V (Flow over seat)	0.99	N/A	0.98	N/A	4000 (276)	
MicroTaper® (Flow under seat)	0.92	0.80	0.90	0.78	N/A	
MicroTaper® (Flow over seat)	0.70	0.45	0.60	0.35	N/A	
Mini-P (Flow under seat)	0.98	N/A	0.96	N/A	2000 (138)	

* Other trim Configurations Maximum Pressure Differential will be limited on Allowable Liquid Velocities

** Consult factory for limitations of using unbalanced trim to flow over seat.

AEROFLOW HIGH PERFORMANCE CONTROL VALVES

How to Specify Aeroflow Control Valves

Valve Body

- 1.1.1 Body should have integrally cast flow control vanes in the inlet, outlet and body gallery to reduce turbulence and allow maximum Cv/Size ratios.
- 1.1.2 Body should be designed with a pressure tap on the inlet side so that adjacent piping penetration points are not needed.
- 1.1.3 Globe and angle body configurations should be designed so that trim modules are fully interchangeable.

Valve Trim

- 1.2.1 Pilot balanced trim to have capability to shutoff to ANSI Class VI or Zero (cc/min) Leakage utilizing metal-to-metal seats.
- 1.2.2 Valve plug should be designed with a three stage labyrinth style plug tip for cavitating services.
- 1.2.3 Trim design should allow for reduction down to a 0.2 factor of full Cv, without changing the original plug or seat ring
- 1.2.4 Cage design should allow for modification of flow win dow for a desired flow characteristic without changing plug assembly.
- 1.2.5 Unbalanced designs should allow for reduction of Cv without reducing seat ring diameter.

Actuators

- 2.1.1 Actuator should be designed in a steel or composite construction that is rated for 150 psig working pressure.
- 2.1.2 Air failure spring should be mounted outside air cylinder to minimize residual air volume.
- 2.1.3 Spring cartridge should be mounted so that accessibility for reversing failure modes is easily accomplished.
- 2.1.4 Actuator/spring assembly shall be designed to provide a low center of gravity for vibration and seismic resistance.

Electro-Pneumatic Positioners

- 3.1.1 Positioner design should include as a standard: built in limit switch contacts and a 4-20mA position transmitter output.
- 3.1.2 Positioner should have a guaranteed accuracy of +0.0012" of calibrated span.
- 3.1.3 Positioner should have a guaranteed repeatability of +0.0012" of span.
- 3.1.4 Hysteresis including dead band should be 0.0%.
- 3.1.5 Positioner steady state air consumption~on should be 0.00 SCFM.

AEROFLOW HIGH PERFORMANCE CONTROL VALVES

UNBALANCED DESIGN Materials/Temperature Specifications

Item	Description	Material	Material Specification
1	Body/Bonnet	Carbon Steel Stainless Steel Chrome-moly Steel	ASTM A-216 GR WCB ASTM A-351 GR CF8M ASTM A-217 GR WC9
2	Valve Plug Mini P Trim only Microtape Trim only	Stainless Steel 13-8 MO Stainless Steel	AISI SST 420 ASTM A-564 AISI SST 431
3	Valve Stem	Nitronic 60	ASTM A-276
4	Piston Ring	Stellite	Stellite #25
5	¹ Cage	Stainless Steel	AISI SST 440
6	Seat Ring	Stainless Steel	AISI SST 440C
10	*Packing Follower	Stainless Steel	AISI SST 303
11	*Packing Flange	Stainless Steel	AISI 1144CF
12	*Hex Nut	Stainless Steel	ASTM A-194 GR4
13	*Studs	Alloy Steel	ASTM A-193 B16
14	*Packing	BTG or Laminated Graphite	
15	Hex Nut	Alloy Steel Alloy Steel (WCB body)	ASTM A-194 GR7 ASTM A-194 GR2
16	Stud	Alloy Steel Alloy Steel (WCB body)	ASTM A-193 B16 ASTM A-193 GR7
17	*Gasket	Graphite	Inconel 600

* Included in all other trim modules unless otherwise listed

¹ Malcolmized® in applications over 800°F (427°C)

NACE Material available upon request

INCONEL® is a trademark of the Inco Family of Companies
MICROTAPER® is a registered trademark of Leslie Controls, Inc.
NITRONIC 60® is a trademark of Armco, Inc.
STELLITE® is a trademark of Stoodly Deloro Stellite, Inc.

AEROFLOW HIGH PERFORMANCE CONTROL VALVES

BALANCED DESIGN

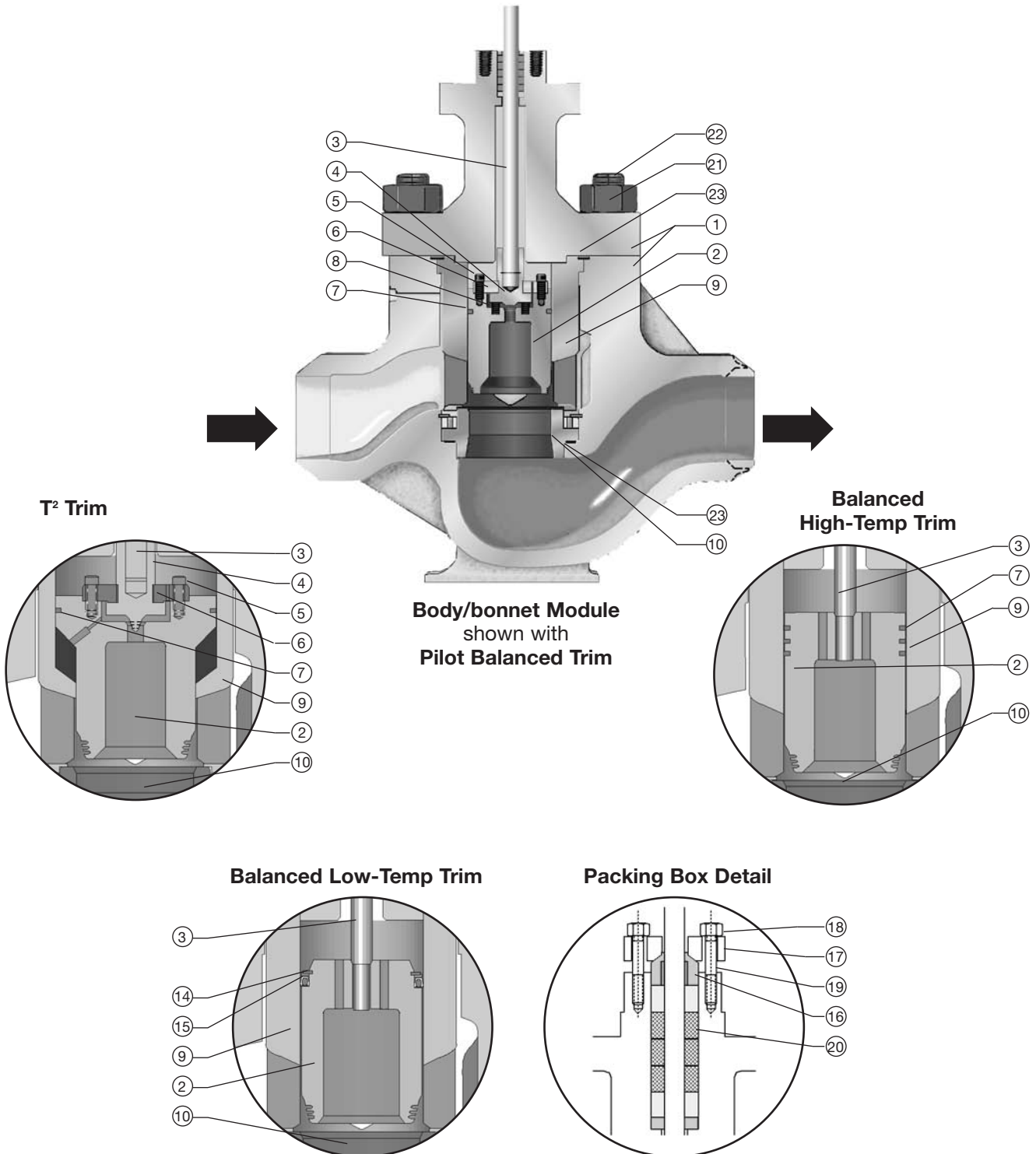

AEROFLOW HIGH PERFORMANCE CONTROL VALVES

BALANCED DESIGN Materials/Temperature Specifications

Item	Description	Material	Material Specification
1	Body/Bonnet	Carbon Steel Stainless Steel Chrome-moly	ASTM A-216 GR WCB ASTM A-351 GR CF8M ASTM A-217 GR WC9
2	Valve Plug	Stainless Steel	AISI 420
3	Valve Stem	Nitronic 60	ASTM A-276
4	Pilot Plug	Stainless Steel	AISI SST 431
5	Socket Head Cap Screw	18-8 Stainless Steel	AISI SST 300
6	Pilot Plate	Stainless Steel	ASTM A-582
7	Piston Ring	Stellite	Stellite #25
8	Spring	Inconel	INCO: x 750
9	*Cage	Stainless Steel	AISI SST 440
10	Seat Ring	Stainless Steel	AISI SST 440 C
14	Seal Retainer	Stainless Steel	ASTM A-240
15	Seal	PTFE	Fluo 36
16	*Packing Follower	Stainless Steel	AISI SST 303
17	*Packing Flange	Stainless Steel	AISI 1144 CF
18	*Hex Nut	Stainless Steel	ASTM A-194 GR4
19	*Studs	Alloy Steel	A-193 B16
20	*Packing	BTG or Laminated Graphite	
21	Hex Nut	Alloy Steel Alloy Steel (WCB only)	ASTM 194 GR7 ASTM 194 GR2H
22	Stud	Alloy Steel Alloy Steel (WCB only)	ASTM 193 B16 ASTM 193 GR7
23	*Gasket	Graphite	Inconel 600

* Common to all trim modules including Les-Cav/Les-Sonic unless otherwise listed

¹ Malcolmized® in applications over 800°F (427°C)

INCONEL® is a trademark of the Inco Family of Companies

NITRONIC 60® is a trademark of Armco, Inc.

STELLITE® is a trademark of Stoodly Deloro Stellite, Inc.

AEROFLOW HIGH PERFORMANCE CONTROL VALVES

Diaphragm Actuator

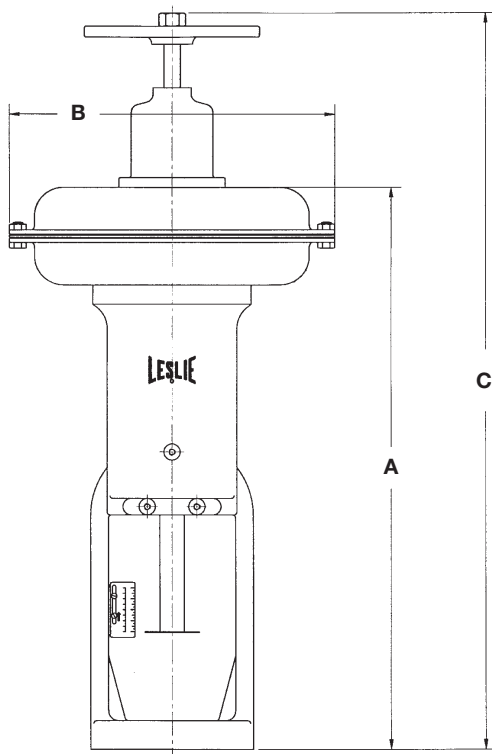

DIAPHRAGM ACTUATOR DOUBLE-ACTING

SIZE	STANDARD		W/optional Handwheel
	"A"	"B"	"C"
55AFR	16 $\frac{1}{4}$	11 $\frac{15}{16}$	25 $\frac{5}{16}$
55AF	18 $\frac{5}{8}$	11 $\frac{15}{16}$	26 $\frac{5}{16}$
85AFR	22 $\frac{15}{32}$	14 $\frac{3}{4}$	31 $\frac{1}{16}$
85AF	25 $\frac{11}{16}$	14 $\frac{3}{4}$	33 $\frac{5}{8}$

Piston Actuator

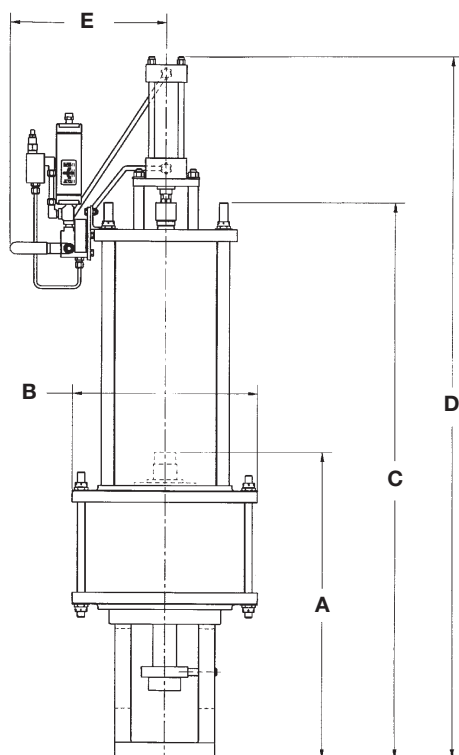

PISTON ACTUATOR DOUBLE-ACTING

SIZE	STANDARD		W/optional Spg. Return	W/optional Hyd. Ov'd	
	"A"	"B"	"C"	"D"	"E"
6"	16 $\frac{1}{2}$	7 $\frac{7}{8}$	25 $\frac{15}{16}$	35 $\frac{5}{8}$	11 $\frac{1}{2}$
10"	17 $\frac{11}{16}$	10 $\frac{1}{2}$	33 $\frac{7}{8}$	45 $\frac{3}{4}$	12 $\frac{13}{16}$
13"	26	15 $\frac{3}{4}$	47 $\frac{5}{16}$	59 $\frac{13}{16}$	13 $\frac{3}{8}$
16"	24 $\frac{3}{4}$	19	42 $\frac{1}{16}$	51 $\frac{13}{16}$	14 $\frac{10}{16}$
20"	24 $\frac{3}{4}$	23	42 $\frac{1}{16}$	51 $\frac{13}{16}$	14 $\frac{11}{16}$

AEROFLOW HIGH PERFORMANCE CONTROL VALVES

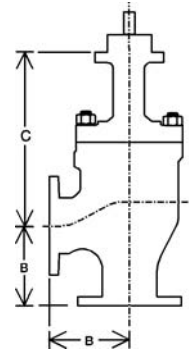
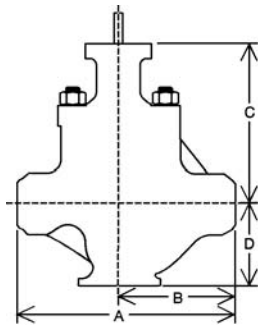

ANSI 150-600 CLASS Dimensions

DIMENSIONS IN INCHES					Shpg. Info. ¹		DIMENSIONS IN MILLIMETERS					Shpg. Info. ¹	
SIZE	A	B	C ²	D	WGT.	VOL.	SIZE	A	B	C ²	D	WGT.	VOL.
ANSI 150/300/600# PN16-100 BWE/SWE							ANSI 150/300/600# PN16-100 BWE/SWE						
1	8¼	4¼	8	3	53 lb.	2 ft ³	25	210	105	203	76	24 kg	0.1 m ³
1½	9½	4½	8	3½	63 lb.	2 ft ³	40	251	125	203	78	29 kg	0.1 m ³
2	11¼	5½	12¾	3½	94 lb.	3 ft ³	50	286	143	324	94	43 kg	0.1 m ³
3	13¼	6¾	14½	4¼	160 lb.	4 ft ³	75	337	168	368	121	73 kg	0.2 m ³
4	15½	7¾	16½	5¼	215 lb.	6 ft ³	100	394	197	419	141	98 kg	0.2 m ³
6	20	10	21¼	6¼	450 lb.	11 ft ³	150	508	254	548	173	204 kg	0.4 m ³
8	24	12	24	8¼	860 lb.	17 ft ³	200	610	305	610	225	390 kg	0.5 m ³
10	29¾	14¼	18¾	9¼	1100 lb.	22 ft ³	250	752	376	476	248	499 kg	0.6 m ³
12	32¼	16¾	20¾	10¼	1700 lb.	27 ft ³	300	819	410	521	273	771 kg	0.8 m ³
16	43¾	21¼	23½	12¼	3200 lb.	53 ft ³	400	1108	552	597	324	1451 kg	1.5 m ³
ANSI 150# PN16 Flanged							ANSI 150# PN16 Flanged						
1	7¼	3¾	8	3	56 lb.	2 ft ³	25	184	92	203	76	25 kg	0.1 m ³
1½	8¼	4¾	8	3½	65 lb.	2 ft ³	40	222	111	203	78	29 kg	0.1 m ³
2	10	5	12¾	3½	95 lb.	3 ft ³	50	254	127	324	94	43 kg	0.1 m ³
3	11¼	5½	14½	4¼	155 lb.	4 ft ³	75	298	149	368	121	70 kg	0.1 m ³
4	13¼	6¼	16½	5¼	230 lb.	5 ft ³	100	352	176	419	141	105 kg	0.2 m ³
6	17¾	8¾	21¼	6¼	505 lb.	9 ft ³	150	451	225	548	173	230 kg	0.3 m ³
8	21¼	10¾	24	8¼	930 lb.	14 ft ³	200	543	270	610	225	423 kg	0.4 m ³
10	26½	14¼	18¾	9¼	1120 lb.	18 ft ³	250	673	376	503	248	508 kg	0.5 m ³
12	29	16¾	20¾	10¼	1730 lb.	23 ft ³	300	737	410	521	273	785 kg	0.7 m ³
16	40	21¼	23½	12¼	3250 lb.	46 ft ³	400	1016	554	597	324	1474 kg	1.3 m ³
ANSI 300# PN40 Flanged							ANSI 300# PN40 Flanged						
1	7¼	3¾	8	3	58 lb.	2 ft ³	25	197	98	203	76	26 kg	0.1 m ³
1½	9¼	4¾	8	3½	67 lb.	2 ft ³	40	235	117	203	78	30 kg	0.1 m ³
2	10½	5¼	12¾	3½	97 lb.	3 ft ³	50	267	133	324	94	44 kg	0.1 m ³
3	12¼	6¼	14½	4¼	160 lb.	4 ft ³	75	311	156	368	121	73 kg	0.1 m ³
4	14¼	7¼	16½	5¼	240 lb.	6 ft ³	100	368	184	419	141	109 kg	0.2 m ³
6	18¾	9¼	21¼	6¼	525 lb.	10 ft ³	150	473	237	548	173	239 kg	0.3 m ³
8	22¾	11¼	24	8¼	950 lb.	15 ft ³	200	568	284	610	225	432 kg	0.5 m ³
10	27¾	13¼	18¾	9¼	1140 lb.	20 ft ³	250	708	354	503	248	517 kg	0.6 m ³
12	30½	15¼	20¾	10¼	1760 lb.	25 ft ³	300	775	387	521	273	798 kg	0.7 m ³
16	41¾	20¼	23½	12¼	3300 lb.	49 ft ³	400	1057	529	597	324	1497 kg	1.4 m ³
ANSI 600# PN64-100 Flanged							ANSI 600# PN64-100 Flanged						
1	8¼	4¼	8	3	59 lb.	2 ft ³	25	210	105	203	76	27 kg	0.1 m ³
1½	9¾	4¼	8	3½	69 lb.	2 ft ³	40	251	125	203	78	31 kg	0.1 m ³
2	11¼	5½	12¾	3½	100 lb.	3 ft ³	50	286	143	324	100	45 kg	0.1 m ³
3	13¼	6¾	14½	4¼	170 lb.	4 ft ³	75	337	168	368	121	77 kg	0.2 m ³
4	15½	7¾	16½	5¼	260 lb.	6 ft ³	100	394	197	419	141	118kg	0.2 m ³
6	20	10	21¼	6¼	550 lb.	11 ft ³	150	508	254	548	173	204 kg	0.3 m ³
8	24	12	24	8¼	1000 lb.	17 ft ³	200	610	305	610	225	455 kg	0.5 m ³
10	29¾	14¼	18¾	9¼	1160 lb.	22 ft ³	250	752	376	476	248	527 kg	0.6 m ³
12	32¼	16¾	20¾	10¼	1840 lb.	28 ft ³	300	819	410	521	273	812 kg	0.8 m ³
16	43¾	21¼	23½	12¼	3350 lb.	53 ft ³	400	1108	554	597	324	1520 kg	1.5 m ³

NOTE: DIMENSIONS ARE SUBJECT TO CHANGE WITHOUT NOTICE. Request certified drawings for piping layout and construction purposes.

1 Approximate weight and volume
2 Consult factory for extended travel (C dimension)

AEROFLOW HIGH PERFORMANCE CONTROL VALVES

ACCESSORIES

Moore Series 760 Positioners

- Pneumatic: Model 760P
- Electropneumatic: Model 760E
- Digital: Model 760D
- Optional internal limit switches
- Optional valve position transmission

Other Positioners

- PMV Series 1200, 2000 and P5
- Hartmann & Braun/Sensycon TZID
- SMAR FY302 Fieldbus
- Siemens PS2
- Bailey AV Series

Process Controllers

- Electropneumatic: Leslie PMC-2
- Pneumatic: Leslie PDAP/PRAP

Solenoid Valves

- ASCO 8320G174 is standard
- Other Asco models, Versa, Skinner, as required

Electric Actuators

- Jordan

Electrohydraulic Actuators

- Rexa L & T Series

Limit Switches

- Westlock
- National Acme (NAMCO)
- Honeywell (Micro)
- GO Proximity Switches

Noise Reduction Devices

- Leslie Noise Suppressor
- Leslie Les-Sonic Silencing Orifice

Air Regulators

- Leslie AFG-2
- Bellofram Type 50
- Control Air Type 300

Other Options

- Handwheels
- Hydraulic Manual Override System
- Limit Stops
- Special Connections
 - Socketweld
 - Butt weld
 - Stub Ends
 - Pipe Reducers
 - Smooth Flange Faces
 - Ring Type Joints

Instruments

- Lockup Valves
- Leslie S-Transfer Valve



Specification form for Measurement and Control Instruments, Primary Elements and Control Valves

 LESLIE CONTROLS, INC. A subsidiary of CIRCOR International, Inc. 12501 Telecom Drive • Tampa, Florida 33637 (813) 978-1000 • FAX: (813) 977-0174		Project/Job _____ Unit/Customer _____ P.O./LCO File # _____ Item _____ Contract _____ MFR Serial# _____			Data Sheet ____ of ____ Spec _____ Tag _____ Dwg _____ Service _____			
		1 Fluid <input type="checkbox"/> Steam <input type="checkbox"/> Water <input type="checkbox"/> Gases <input type="checkbox"/> Liquid Crit Pres PC						
2	S	Flow	<input type="checkbox"/> #/hr <input type="checkbox"/> gpm <input type="checkbox"/> scfh	Max. Flow	Norm. Flow	Min. Flow	Shut-off	
	E		<input type="checkbox"/> kg/hr. <input type="checkbox"/> <input type="checkbox"/> m ³ /hr <input type="checkbox"/>				--	
3	R	Inlet Press.	<input type="checkbox"/> psig <input type="checkbox"/> psia <input type="checkbox"/> kg/cm ² <input type="checkbox"/>				psig	
4	V	Outlet Press.	<input type="checkbox"/> psig <input type="checkbox"/> psia <input type="checkbox"/> kg/cm ² <input type="checkbox"/>				psig	
5	I	Temperature	<input type="checkbox"/> °C <input type="checkbox"/> °F					
6	C	Spec. Wt./Spec. Grav./Mol. Wgt.						
7	E	Viscosity/Spec. Heats Ratio					--	
8		Vapor Pressure Pv	<input type="checkbox"/> psia <input type="checkbox"/>				--	
9	C	*Required Cv					--	
10	O	*Travel %					--	
11	N	Allowable/*Predicted SPL (dBA)					0	
12	D	FL _____ XT _____						
13	L	Pipe Size/Sch. In	_____/Sch	49	*Type <input type="checkbox"/> DA <input type="checkbox"/> SR <input type="checkbox"/> DASR			
14	I	Pipe Size/Sch. Out	_____/Sch		<input type="checkbox"/> Diaph <input type="checkbox"/> EHA <input type="checkbox"/> Electr. <input type="checkbox"/> Other			
15	N	Pipe Line Insulation	in. _____	50	*Mfr./Model _____ / _____			
16	V A L V E	Type	<input type="checkbox"/> Globe <input type="checkbox"/> Angle	51	*Size/Eff Area <input type="checkbox"/> 6"/28 in ² <input type="checkbox"/> 10"/80 in ² <input type="checkbox"/> 13"/130 in ²			
17		*Body Size in.	<input type="checkbox"/> 1 <input type="checkbox"/> 1 1/2 <input type="checkbox"/> 2 <input type="checkbox"/> 3 <input type="checkbox"/> 4		<input type="checkbox"/> 16"/200 in ² <input type="checkbox"/> 20"/300 in ² <input type="checkbox"/> Other			
			<input type="checkbox"/> 6 <input type="checkbox"/> 8 <input type="checkbox"/> 10 <input type="checkbox"/> 12 <input type="checkbox"/> 16 <input type="checkbox"/> _____		<input type="checkbox"/> On/Off <input type="checkbox"/> Modulating			
		ANSI Class	<input type="checkbox"/> 150 <input type="checkbox"/> 300 <input type="checkbox"/> 600 <input type="checkbox"/> _____		Spring Action/Air Failure <input type="checkbox"/> Open <input type="checkbox"/> Closed <input type="checkbox"/> None			
			<input type="checkbox"/> 900 <input type="checkbox"/> 1500 <input type="checkbox"/> 2500 <input type="checkbox"/> 4500		Spring # _____			
18		Design. Press. Temp	_____/_____		*Max. Allowable Press. _____			
19		Mfr./Model:	Leslie/Aeroflow		*Min. Required Press. _____ psig			
20		Body/Bonnet Mat'l	<input type="checkbox"/> WCB <input type="checkbox"/> WC9 <input type="checkbox"/> CF8M		Available Air Supply Press. _____			
			<input type="checkbox"/> C5 <input type="checkbox"/> WC6 <input type="checkbox"/>		Max. _____ Min. _____			
21		End Conn Inlet/Outlet	<input type="checkbox"/> Flg RF <input type="checkbox"/> Thd <input type="checkbox"/> RTJ		*Bench Range _____ psig <input type="checkbox"/> N/A			
		<input type="checkbox"/> SWE _____ <input type="checkbox"/> BWE/Sch _____		Act. Orientation <input type="checkbox"/> Horiz. <input type="checkbox"/> Vert.				
		<input type="checkbox"/> In BWE/Sch _____ <input type="checkbox"/> In SWE _____		Override Type <input type="checkbox"/> Manual Hyd. <input type="checkbox"/> None				
		<input type="checkbox"/> Out BWE/Sch _____ <input type="checkbox"/> Out SWE _____		Air Failure Valve <input type="checkbox"/> Opens <input type="checkbox"/> Closes <input type="checkbox"/> Last				
		<input type="checkbox"/> In Stubs/Sch _____ Length (in.) _____		Tubing <input type="checkbox"/> SST <input type="checkbox"/> Copper <input type="checkbox"/> 3/8" <input type="checkbox"/> 1/2" <input type="checkbox"/>				
		<input type="checkbox"/> Out Stub/Sch _____ Length (in.) _____		Data Tag: <input type="checkbox"/> Brass <input type="checkbox"/> SST				
		<input type="checkbox"/> Exp _____ x _____ In/Sch _____		Solenoid: <input type="checkbox"/> Asco/8320G174 <input type="checkbox"/> None				
		<input type="checkbox"/> Exp _____ x _____ Out/Sch _____		<input type="checkbox"/> Other Mfr./Model _____ / _____				
22	Fig. Face Finish	RMS <input type="checkbox"/> Std. (125-500)		Input Signal <input type="checkbox"/> 3-15 psi <input type="checkbox"/> 4-20 mA <input type="checkbox"/>				
23	End Ext/Mat'l.	_____		*Type <input type="checkbox"/> Pneu. (750P) <input type="checkbox"/> I/P(750E) <input type="checkbox"/> DPS <input type="checkbox"/> None				
24	*Flow	<input type="checkbox"/> Over <input type="checkbox"/> Under Seat		<input type="checkbox"/> Other *Mfr./Model _____ / _____				
25	*Type Bonnet	<input type="checkbox"/> Std <input type="checkbox"/> Ext		*On Incr. Signal Output <input type="checkbox"/> Incr. <input type="checkbox"/> Decr.				
26	Lub & Isol Valve	<input type="checkbox"/> Yes <input type="checkbox"/> No		Gauges <input type="checkbox"/> Yes <input type="checkbox"/> No, <input type="checkbox"/> By-Pass <input type="checkbox"/> Yes <input type="checkbox"/> No				
27	Lube	<input type="checkbox"/> Yes <input type="checkbox"/> No		*Cam Charact. <input type="checkbox"/> Linear <input type="checkbox"/> =% <input type="checkbox"/> Sq. Root				
28	*Packing Mat'l	<input type="checkbox"/> LG <input type="checkbox"/> BTG		*Type <input type="checkbox"/> Mech (Namco EA170-1100) <input type="checkbox"/> None				
		<input type="checkbox"/> DTFE <input type="checkbox"/>		<input type="checkbox"/> Other *Mfr./Model _____ / _____				
29	*Type	<input type="checkbox"/> UBC <input type="checkbox"/> UBP <input type="checkbox"/> MT <input type="checkbox"/> Mini-P		Contacts/Rating <input type="checkbox"/> Other <input type="checkbox"/> SPDT <input type="checkbox"/> DPDT				
		<input type="checkbox"/> BH <input type="checkbox"/> BL <input type="checkbox"/> PB <input type="checkbox"/> T2		Actuation points: <input type="checkbox"/> Both <input type="checkbox"/> Open <input type="checkbox"/> Closed				
30	Les-Sonic Cage	<input type="checkbox"/> Yes <input type="checkbox"/> No		NEMA Class 1,4, &13				
31	Les-Cav	<input type="checkbox"/> I <input type="checkbox"/> II <input type="checkbox"/> III <input type="checkbox"/> IV <input type="checkbox"/> V		*Mfr./Model: Leslie/ <input type="checkbox"/> AFG-2 <input type="checkbox"/> None				
32	*Characteristic	<input type="checkbox"/> Linear <input type="checkbox"/> =% <input type="checkbox"/> QO		*Set Press. <input type="checkbox"/> _____ PSIG <input type="checkbox"/> _____ / _____				
		<input type="checkbox"/> Custom		Filter <input type="checkbox"/> Yes <input type="checkbox"/> No, <input type="checkbox"/> Gauge <input type="checkbox"/> Yes <input type="checkbox"/> No				
33	Travel	<input type="checkbox"/> STD <input type="checkbox"/> Ext <input type="checkbox"/> Max		Range: <input type="checkbox"/> 3-60 psi <input type="checkbox"/> 30-150psi <input type="checkbox"/>				
34	*Rated Cv	% Max. Cv = _____		*Hydro Pressure				
35	*Plug Mat'l	<input type="checkbox"/> 420 <input type="checkbox"/>		ANSI/FCI Leakage Class <input type="checkbox"/> III <input type="checkbox"/> IV				
36	Pilot Valve Material	<input type="checkbox"/> 431 <input type="checkbox"/>		<input type="checkbox"/> V <input type="checkbox"/> VI <input type="checkbox"/> Zero CC/min				
37	*Seat Ring Mat'l	<input type="checkbox"/> 440C <input type="checkbox"/>		No Service Cond. Available <input type="checkbox"/>				
38	*Cage Mat'l	<input type="checkbox"/> 440A <input type="checkbox"/>		Attached Cv Calcs <input type="checkbox"/> Yes <input type="checkbox"/> No				
39	Stem Mat'l	<input type="checkbox"/> Nitronic® 60 <input type="checkbox"/>		Special Factory Instr. Attached <input type="checkbox"/> Yes <input type="checkbox"/> No				
40	NEC Class	Group _____ Div. _____		Shipping Schedule: _____ weeks ARO				
41				SRI# _____ Date _____				
42				Approx. Weight _____ lbs. each				
43				Qty. _____ Approx. Weight _____ lbs. Total				
44				Unit Net Price \$ _____ each				
45				Extension Net Price \$ _____ Total				
46				Leslie Quote # _____				
47				Rev.	Date	Revision	Orig	
48							App	



NOTES:



NOTES:



NOTES:

Commitment to Excellence



ISO 9001
CN 30057

Fabrication, Service & Repair

Remanufacturing, Testing, Preventative Maintenance, Customer Training and Fabrication

Circor International operates three service centers (New Jersey, Virginia and Florida) where valves of many major manufacturers are returned to original factory specifications and given a new service warranty at a fraction of the original purchase cost. We also have an international network of Leslie licensed and trained "Red Seal" Service Centers capable of performing the same quality of work as our service centers.

Circor Service Centers are also authorized to service valves manufactured by K&M, R.G. Laurence, CPC-Cryolab, Spence Engineering, Nicholson, KF, Circle Seal, SSI Equipment, Hoke, Aerodyne Controls, SKVC, Watts ACV, Go Regulator, Pibiviesse, Telford, Chas. M. Bailey, and Contromatics.

In addition to handling factory repairs, each Service Center has available factory trained Field Service Technicians to provide

on-site repairs and preventative maintenance where removal is impractical or extended shutdown is unacceptable. Circor Service Centers also provide custom tailored, in-depth, hands-on training programs in operation, instrumentation and maintenance of all supported equipment. Training is conducted at one of our specially designed, fully equipped repair facilities or at your location using your own equipment.

Another service provided at the Circor Service Centers is panel board fabrication. Whenever it is not practical to assemble components on-site, our experts can design, build, and ship or deliver and install a unit customized to suit your needs.

Service is a fundamental part of the Leslie operating philosophy and we urge you to request additional documentation and descriptive material.

* Assessed and certified by ABS Quality Evaluations, Inc., Houston, Texas

Since LESLIE CONTROLS was founded in 1900, we have been an industry leader in quality fluid control equipment. We have developed a full line of engineered products to suit your requirements, including diaphragm control valves, control instrumentation, pressure and temperature regulators and steam water heaters.



LESLIE
CONTROLS, INC.

A subsidiary of CIRCOR International, Inc.

12501 Telecom Drive
Tampa, FL 33637-0906

www.lesliecontrols.com

(813) 978-1000 • FAX: (813) 977-0174