

K-MAX

ROTARY CONTROL VALVES
ANSI 150-600 CLASS



LESLIE
CONTROLS, INC.

A subsidiary of **CIRCOR** International, Inc.

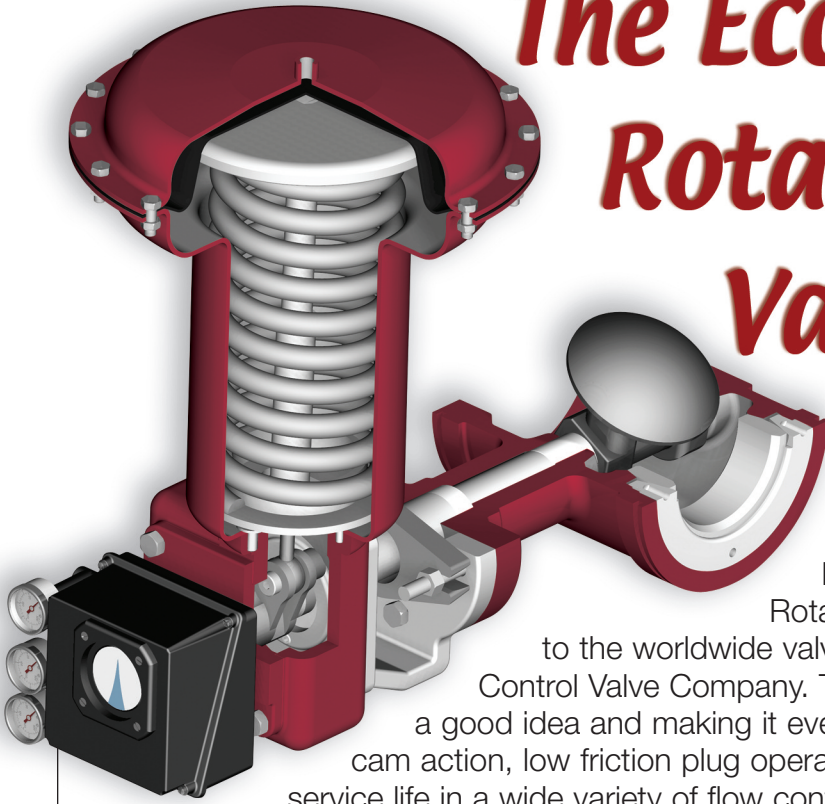

The Eccentric Rotary Control Valve has **EVOLVED!**

Leslie Controls' **K-MAX** Eccentric Plug Rotary Control Valve was originally introduced to the worldwide valve market by the K&M (Kieley & Mueller) Control Valve Company. The **K-MAX** is a classic case of taking a good idea and making it even better. It's design still incorporates the cam action, low friction plug operation that provides tight shutoff over long service life in a wide variety of flow control applications.

The **K-MAX** Rotary Control Valve has improved on the performance and durability of traditional rotary control valves with the addition of these features:

■ Economical Design

The inherent versatility of the K-Max offers the advantage of using one valve style for many applications, allowing for plant standardization and minimal stocking requirements. In addition, the efficient straight-through flow design allows for a much lower cost per C, than conventional globe style control valves.

■ Eccentric Rotary Plug Action

The K-Max plug is offset to the shaft centerline. This allows the plug to break free of the seat ring immediately upon initial rotation of the shaft. Since there is no sliding contact between the plug and the seat ring throughout travel, seat ring life and shutoff integrity are greatly enhanced.

■ Self-aligning Orbital Seat

This innovative design allows orbital movement of the seat ring to provide self-alignment with the plug at assembly. Once seat ring to plug alignment is made, the seat is locked in place by the seat ring retainer. The seat ring and plug rigidly mate with every closure of the valve, maintaining excellent shutoff capability.

■ Rangeability

Rangeability of the K-Max valve is 100:1, allowing precise throttling over a wide range of flows.

■ Bi-directional Flow Capability

The normal flow direction for clean liquids, gases, and steam is flow to open (flow into the face of the plug). The recommended flow direction for erosive and slurry service is flow to close (flow into the backside of the plug). Shutoff class is maintained in either flow direction.

features

Maximum Service Life assured by these standard features:

- 1 **Dual Spline Driven Shaft**
- 2 **Large Diameter 17-4PH Stem**
- 3 **Triple Bearing Shaft Support**

- 4 **Long Packing Life and Minimized Emissions Hazard** provided by rotary valve operation.

- 5 **Fewer Possible Leak Paths** due to one piece, integral bonnet design.

- 6 **Easy Trim Size Changes** modify valve C_v by simply replacing seat ring.

- 7 **Customized Trim Options** include Stainless Steel, Stellite®, and other alloys for a variety of applications such as:

- Slurry Service
- Corrosive Chemicals
- Erosive Conditions
- Superheated Steam

- 8 **Tight Shutoff over Extended Service Life** provided by low friction, cam action offset plug mated with self-aligning orbital seat.

- 9 **Easy Maintenance and Clean-out** assured by standard shaft access plug.

Variety of End Connections

- Wafer Style (150, 300, 600 ANSI Class)
- Separable Flanged (150, 300 ANSI Class)
- Integral Flanged (150, 300, 600 ANSI Class)

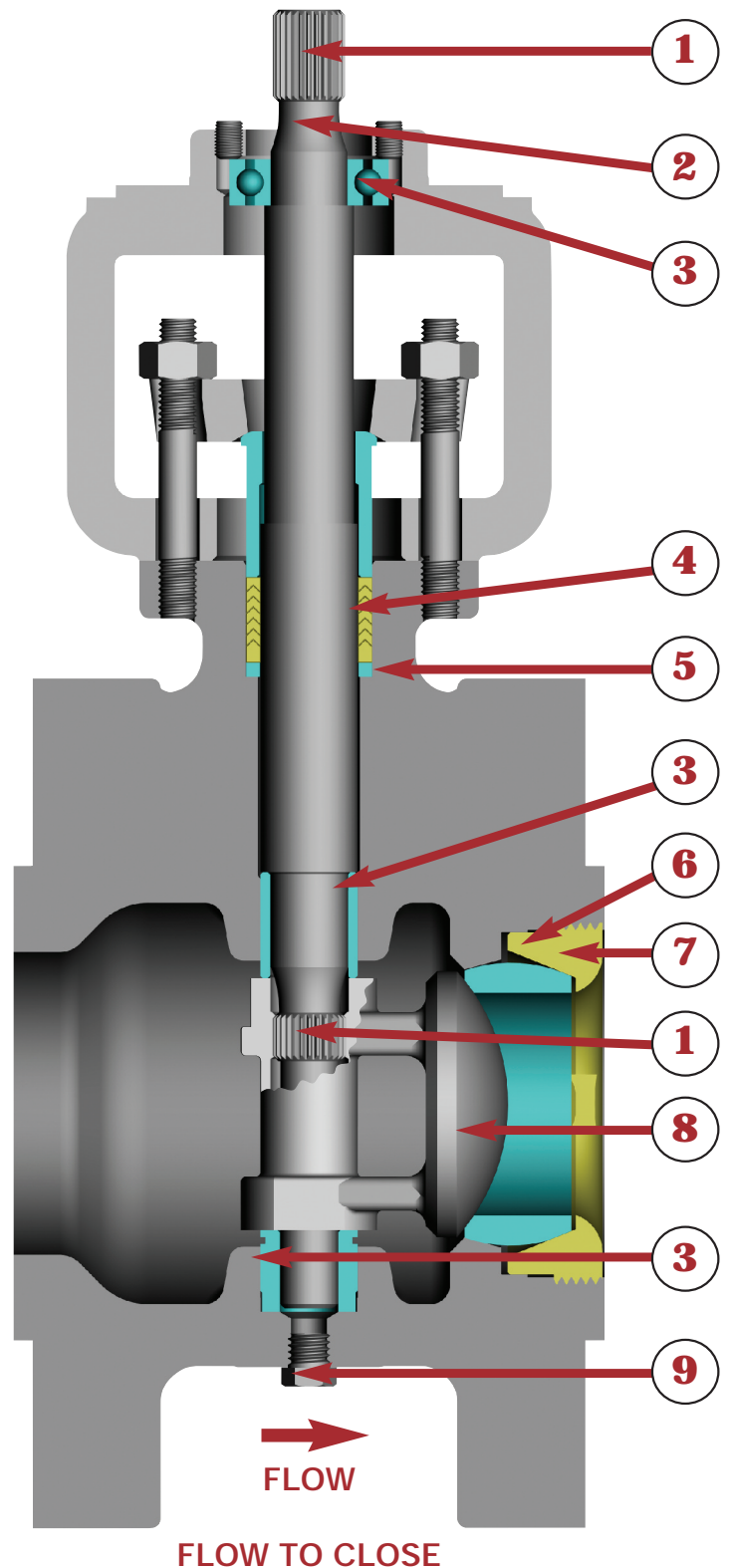

technical specifications

Valve Style:

High performance eccentric rotary plug control valve.

Valve Size:

Sizes 1" through 8" (25mm-200mm) with full or reduced port trim.

End Connection:

Flangeless ANSI class 150, 300 or 600, sizes 1" - 8".
 Separable flanged ANSI class 150 or 300, sizes 1" - 6".
 Integral flanged ANSI class 150, 300 or 600, sizes 1" - 8".

Note: Serrated raised face flanges are standard. Smooth raised face flanges, DIN and JIS flanges, available on application.

Seat Seal

- Metal to metal seat (standard) - ANSI Class IV
- Metal to metal seat (optional) - ANSI Class V
- PTFE soft seat - ANSI Class VI

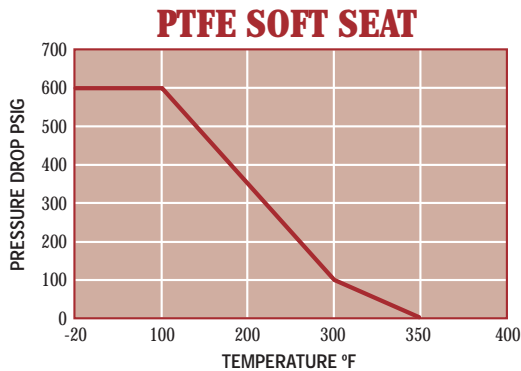

The inherent flow characteristic of the K-Max valve is linear. When required, the valve travel can be modified with a positioner cam adjustment to provide equal percent flow characteristic.

FLOW CHARACTERISTIC

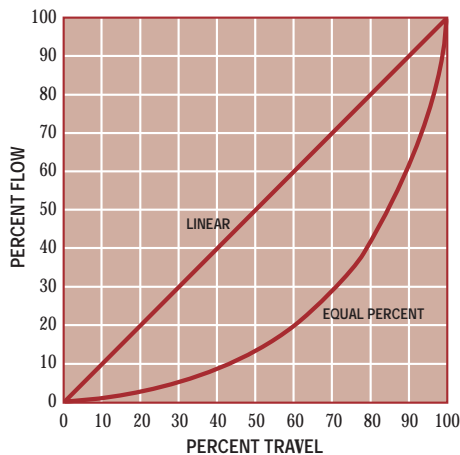

Body Material:

Carbon steel, ASTM A216 grade WCB
 316 stainless steel, ASTM A351 grade CF8M

Packing:

Packing Type	Temperature Range
Teflon [®] Chevron	-40°F through +450°F
Laminated Graphite	-300°F through +800°F
Teflon [®] Chevron with Viton Bearing Seals	-40°F through +450°F

Trim Material:

See K-Max valve material specifications.

Note: Other trim combinations available on application.

Alloy 6 Trim Options:

No Alloy 6

No Alloy 6 on seat ring or plug.

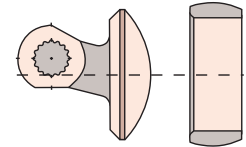

Partial Alloy 6

Alloy 6 on seat ring and plug seating surfaces.

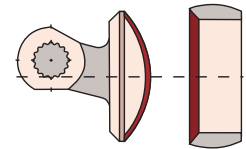

Full Alloy 6

Alloy 6 on seat ring bore in addition to seat ring and plug seating surfaces.

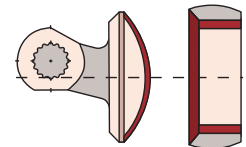

ALLOY 6 RECOMMENDED USAGE

(ANSI CLASS 600 RATING)

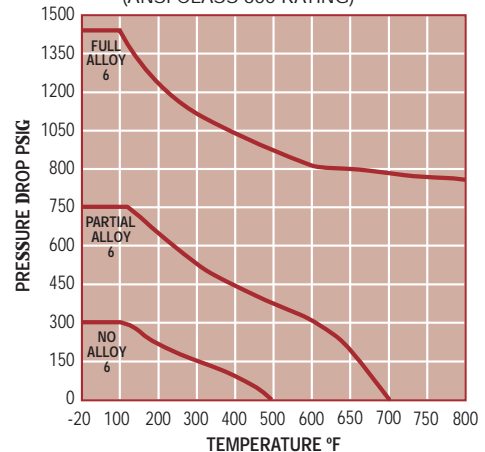

technical specifications

TRIM SIZE

Full size trim	-	100% capacity
.6 reduced trim	-	60% of full capacity
.4 reduced trim	-	40% of full capacity
.2 reduced trim	-	20% of full capacity

Note:
Other trim sizes available
on application.

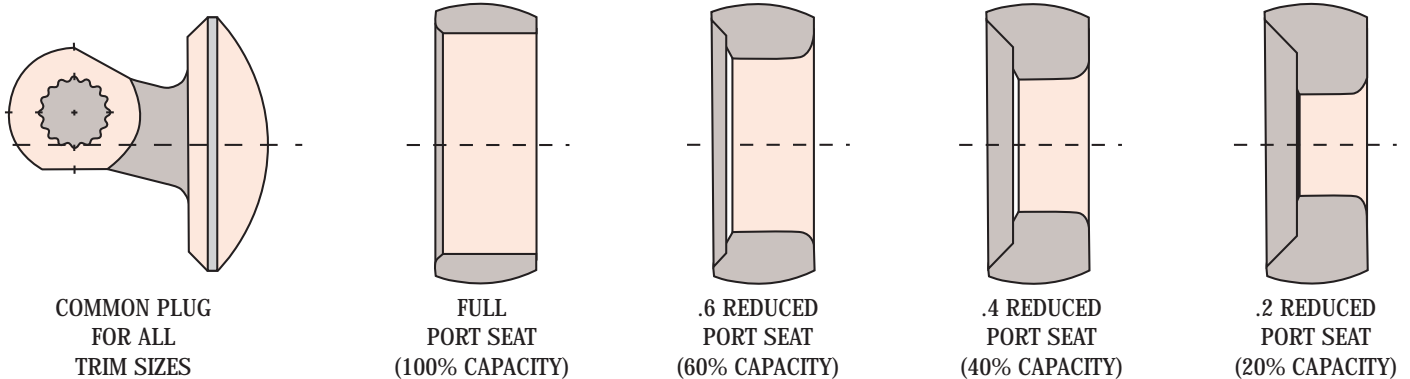

OPTIONS

- Fluoroelastomer bearing seal for slurry service
- Kalrez® bearing seal for slurry service
- 316 stainless steel separable flanges and retaining rings
- 316 stainless steel valve to actuator bolting
- NACE trim - conforms to NACE MR0103 & MR0175

STANDARD CLASS

Temp. °F	Working Pressure by Classes, psig		
	150	300	600
-20 to 100	285	740	1480
200	260	675	1350
300	230	655	1315
400	200	635	1270
500	170	600	1200
600	140	550	1095
650	125	535	1075
700	110	535	1065
750	95	505	1010
800	80	410	825
850	65	270	535
900	50	170	345
950	35	105	205
1000	20	50	105

Not recommended for prolonged usage above about 800°F

RECOVERY COEFFICIENTS F_L (ALL FLUIDS) & CAVITATION INDEX K_C (LIQUIDS)

Valve Opening %	Flow to Open		Flow to Close	
	F_L	K_C	F_L	K_C
100	.88	.60	.75	.56
90	.89	.61	.74	.49
80	.89	.62	.73	.49
70	.90	.63	.73	.49
60	.89	.62	.75	.50
50	.89	.61	.78	.51
40	.88	.61	.80	.52
30	.88	.60	.82	.53
20	.87	.59	.84	.55
10	.87	.59	.85	.55

Note: For calculating the pressure drop at which cavitation will begin, ΔP_c multiply K_C by the quantity $P_1 - P_v$, where P_1 = upstream pressure (PSIA), and P_v = vapor pressure (PSIA). $\Delta P_c = K_C (P_1 - P_v)$.

specifications

Trim Material Code	Body Material	Plug Material	Seat Ring Material		Shaft Material	Bearing Material
			Size 2" - 8" full trim valves	Size 1" - 1.5" full trim valves and size 1" - 8" reduced trim valves		
S	Carbon Steel ASTM A216 WCB	316 Stainless Steel ASTM A351 CF8M w/hardened electroless nickel coating	316 Stainless Steel ASTM A351 CF8M Hardness Brinell 150	316 Stainless Steel ASTM A479 316 Hardness Brinell 150	17-4 PH Stainless Steel ASTM A564 S17400 condition H900 Hardness Rockwell C 40	440C Stainless Steel ASTM A276 S44004 Hardness Rockwell C 58
	316 Stainless Steel ASTM A351 CF8M	316 Stainless Steel ASTM A351 CF8M w/hardened electroless nickel coating	316 Stainless Steel ASTM A351 CF8M Hardness Brinell 150 nickel coating	316 Stainless Steel ASTM A479 316 Hardness Brinell 150	17-4 PH Stainless Steel ASTM A564 S17400 condition H900 Hardness Rockwell C 40	Alloy 6 AMS 5387B Hardness Rockwell C 37-41
P or F	Carbon Steel ASTM A216 WCB	316 Stainless Steel ASTM A351 CF8M w/Alloy 6 hard overlay AWS A5.13 RCoCr - A Hardness Rockwell C 38 - 47	Alloy 6	316 Stainless Steel ASTM A479 316 Alloy 6 Hardness Rockwell C 38 - 47	17-4 PH Stainless Steel ASTM A564 S17400 condition H900 Hardness Rockwell C 40	440C Stainless Steel ASTM A276 S44004 Hardness Rockwell C 58
	316 Stainless Steel ASTM A315 CF8M	316 Stainless Steel ASTM A351 CF8M w/Alloy 6 hard overlay AWS A5.13 RCoCr - A Hardness Rockwell C 38 - 47	Alloy 6	316 Stainless Steel ASTM A479 316 Alloy 6 Hardness Rockwell C 38 - 47	17-4 PH Stainless Steel ASTM A564 S17400 condition H900 Hardness Rockwell C 40	Alloy 6 AMS 5387B Hardness Rockwell C 37-41

Note: Seat ring retainer material is the same as the base plug material.

actuator dimensions

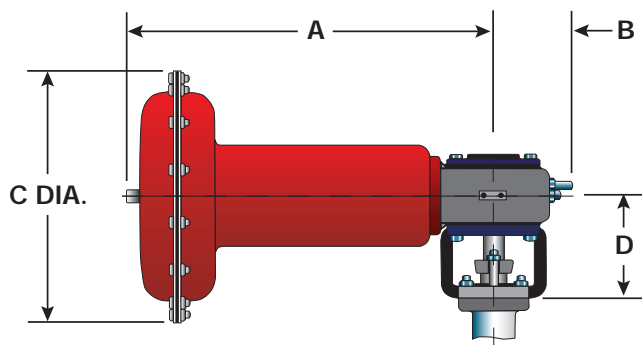

ACTUATOR DIMENSIONS inches (mm) AND WEIGHTS pounds (kg)

Actuator Size	Dimensions				Weights
	A	B	C	D	
40	11.25 (286)	3.50 (88.9)	10.12 (257)	6.50 (165)	29 (13)
55	18.50 (470)	5.25 (133)	12.00 (305)	6.56 (167)	80 (36)
85	19.88 (505)	5.25 (133)	14.75 (375)	7.44 (189)	110 (50)

ACTUATOR MOUNTING POSITIONS

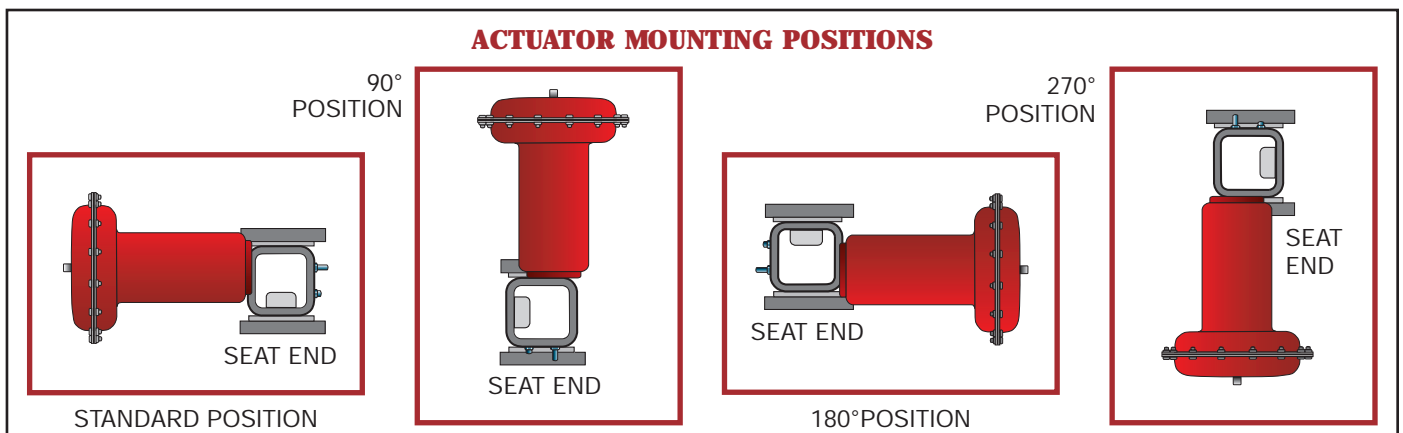

body dimensions

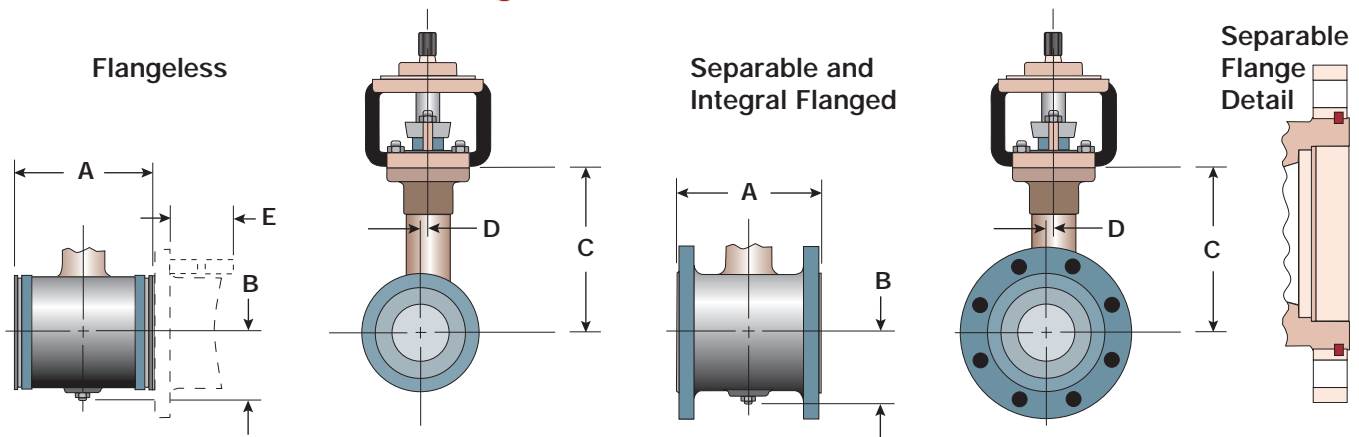

BODY DIMENSIONS inches (mm) **AND WEIGHTS** pounds (kg)

Size	DIMENSIONS													WEIGHTS			
	A	B	C	D	E	F	G	H	J	K	L	M	N	Flgless	FL150	FL300	FL600
1 (25)	4 (102)	2 ¹ / ₁₆ (62)	4 ¹ / ₁₆ (113)	5 ¹ / ₃₂ (4.06)	7 ¹ / ₁₆ (194)	1 (25)	1 ¹ / ₂ (38.1)	1 ¹ / ₁₆ (17.5)	—	1 ⁵ / ₁₆ (23.9)	—	7 ¹ / ₁₆ (11.2)	3 ³ / ₄ (82.6)	9 (4.1)	12 (5.4)	14 (6.4)	17 (7.7)
1 ¹ / ₂ (40)	4 ¹ / ₂ (114)	2 ³ / ₄ (69.8)	5 ¹ / ₁₆ (130)	3 ¹ / ₄ (6.35)	8 ³ / ₄ (222)	1 (25)	1 ¹ / ₂ (38.1)	1 ¹ / ₁₆ (17.5)	—	1 ⁵ / ₁₆ (23.9)	—	7 ¹ / ₁₆ (11.2)	3 ³ / ₄ (82.6)	13 (5.9)	18 (8.2)	23 (10)	27 (12)
2 (50)	4 ⁷ / ₁₆ (124)	2 ³ / ₁₆ (71.4)	4 ⁷ / ₁₆ (124)	7 ¹ / ₃₂ (5.59)	9 ¹ / ₁₆ (232)	1 (25)	1 ¹ / ₂ (38.1)	1 ¹ / ₁₆ (17.5)	—	1 ⁵ / ₁₆ (23.9)	—	7 ¹ / ₁₆ (11.2)	3 ³ / ₄ (82.6)	14 (6.4)	21 (9.5)	25 (11)	30 (14)
3 (80)	6 ¹ / ₂ (165)	3 ³ / ₁₆ (90.4)	5 ³ / ₄ (146)	5 ¹ / ₁₆ (7.87)	11 ¹ / ₂ (292)	1 ¹ / ₄ (32)	2 ¹ / ₁₆ (62)	1 ³ / ₁₆ (20.6)	7 ¹ / ₁₆ (22.4)	3 ¹ / ₄ (19)	5 (125)	6 ¹ / ₁₆ (14.2)	6 ¹ / ₂ (165)	31 (14)	43 (20)	52 (24)	58 (26)
4 (100)	7 ¹ / ₁₆ (194)	4 (100)	7 (178)	7 ¹ / ₁₆ (11.2)	13 ³ / ₁₆ (340)	1 ¹ / ₄ (32)	2 ¹ / ₁₆ (62)	1 ³ / ₁₆ (20.6)	7 ¹ / ₁₆ (22.4)	3 ¹ / ₄ (19)	5 (125)	6 ¹ / ₁₆ (14.2)	6 ¹ / ₂ (165)	42 (19)	60 (27)	76 (34)	100 (45)
6 (150)	9 (229)	5 ¹ / ₁₆ (129)	9 ¹ / ₁₆ (244)	1 ¹ / ₁₆ (16.8)	15 ³ / ₄ (400)	1 ³ / ₄ (44.4)	2 ¹ / ₁₆ (58.7)	1 ⁵ / ₁₆ (23.9)	7 ¹ / ₁₆ (11.2)	1 ¹ / ₁₆ (16.8)	5 (125)	6 ¹ / ₁₆ (14.2)	6 ¹ / ₂ (165)	97 (44)	119 (54)	152 (69)	207 (94)
8 (200)	9 ¹ / ₁₆ (243)	6 (150)	11 (279)	7 ¹ / ₁₆ (22.4)	17 ³ / ₄ (438)	1 ³ / ₄ (44.4)	2 ¹ / ₁₆ (58.7)	1 ⁵ / ₁₆ (23.9)	7 ¹ / ₁₆ (11.2)	1 ¹ / ₁₆ (16.8)	5 (125)	6 ¹ / ₁₆ (14.2)	6 ¹ / ₂ (165)	144 (65)	180 (82)	222 (101)	304 (138)

- Note: 1. All dimensions are subject to change without notice. Request certified drawings for use in preparing piping layouts.
 2. Flange dimensions conform to ANSI B16.5.
 3. Face-to-face dimensions conform to ISA S75.04.
 4. Weights shown do not include crating.

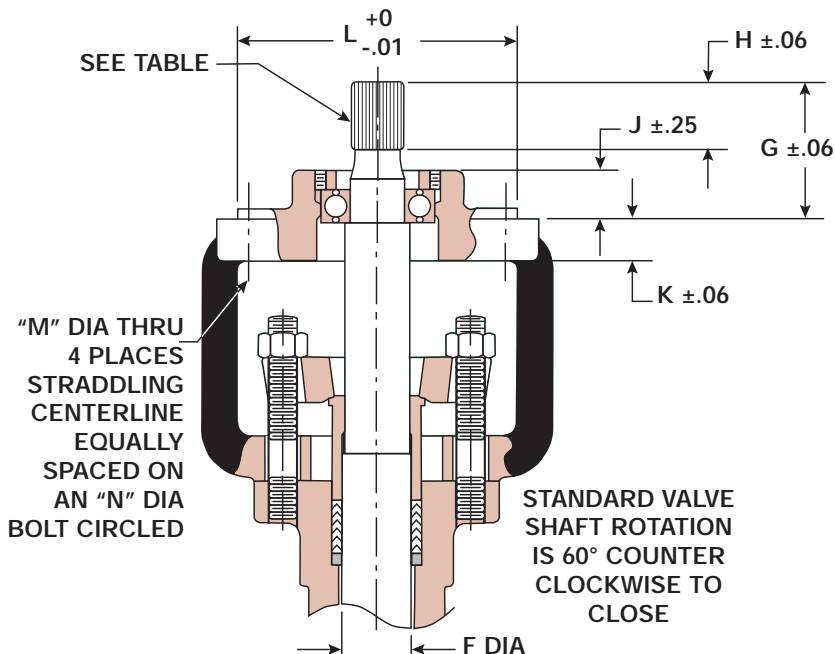

EXTERNAL INVOLUTE SPLINE DATA TABLE
(Inches)

Feature	Valve Size		
	1, 1.5, 2	3, 4	6, 8
Fillet Root Side Fit			
Number of teeth	28	28	52
Pitch	40/80	32/64	40/80
Pressure angle	30°	30°	30°
Base diameter	.6062	.7578	1.1258
Pitch diameter	.7	.875	1.3
Major diameter	.725/.722	.906/.903	1.325/1.322
Form diameter	.671	.839	1.271
Minor diameter	.638	.8	1.236
Circular Tooth Thickness			
Max. effective	.0390	.0491	.0393
Min. actual	.0366	.0464	.0361

C_v Tables

FLOW COEFFICIENTS (C_v), LINEAR CHARACTERISTIC

FLOW TO OPEN		Percent Travel (60°) Rotation									
Valve Size	Trim Size	10%	20%	30%	40%	50%	60%	70%	80%	90%	100%
1	Full	1.3	2.8	4.2	5.9	7.8	9.1	11	12	13	14
	.6 reduced	.76	1.6	2.5	3.5	4.8	5.5	6.4	7.4	7.9	8.4
	.4 reduced	.50	1.1	1.7	2.4	3.2	3.7	4.3	4.9	5.3	5.6
	.2 reduced	.25	.53	.84	1.2	1.6	1.8	2.1	2.5	2.6	2.8
1.5	Full	2.9	6.1	9.6	13	18	21	24	28	30	32
	.6 reduced	2.7	5.7	9.0	11	12	13	15	17	18	20
	.4 reduced	1.2	2.5	3.9	5.5	7.4	8.6	9.8	11	12	13
	.2 reduced	.59	1.2	2.0	2.8	3.7	4.3	4.9	5.7	6.1	6.5
2	Full	4.6	9.7	15	21	29	34	39	45	48	51
	.6 reduced	2.7	5.7	9.0	13	17	20	23	26	28	30
	.4 reduced	1.8	3.8	6.0	8.4	11	13	15	18	19	20
	.2 reduced	.90	1.9	3.0	4.2	5.7	6.6	7.6	8.8	9.4	10
3	Full	14	29	45	63	86	99	114	132	141	150
	.6 reduced	8.1	17	27	38	51	59	68	79	85	90
	.4 reduced	5.4	11	18	25	34	40	46	53	56	60
	.2 reduced	2.7	5.7	9.0	13	17	20	23	26	28	30
4	Full	22	47	74	104	141	163	187	217	232	247
	.6 reduced	13	28	44	62	84	97	112	129	138	147
	.4 reduced	8.8	19	29	41	56	65	75	86	92	98
	.2 reduced	4.4	9.3	15	21	28	32	37	43	46	49
6	Full	47	99	156	218	296	343	395	458	489	520
	.6 reduced	28	59	89	125	170	206	225	275	294	312
	.4 reduced	19	40	59	83	113	137	150	183	196	208
	.2 reduced	9.4	20	30	42	57	69	75	92	98	104
8	Full	78	165	261	365	496	574	661	766	818	870
	.6 reduced	47	99	156	219	297	345	396	459	491	522
	.4 reduced	31	66	104	146	198	230	264	306	327	348
	.2 reduced	16	33	52	73	99	115	132	153	164	174

FLOW TO CLOSE		Percent Travel (60°) Rotation									
Valve Size	Trim Size	10%	20%	30%	40%	50%	60%	70%	80%	90%	100%
1	Full	1.4	2.9	4.5	6.3	8.6	9.9	11	13	14	15
	.6 reduced	.81	1.7	2.7	3.8	5.1	5.9	6.8	7.9	8.5	9.0
	.4 reduced	.54	1.1	1.8	2.5	3.4	4.0	4.6	5.3	5.6	6.0
	.2 reduced	.27	.57	.90	1.3	1.7	2.0	2.3	2.6	2.8	3.0
1.5	Full	3.1	6.5	10	14	19	22	26	30	32	34
	.6 reduced	1.9	4.0	6.3	8.8	12	14	16	19	20	21
	.4 reduced	1.3	2.7	4.2	5.9	8.0	9.2	11	12	13	14
	.2 reduced	.63	1.3	2.1	2.9	4.0	4.6	5.3	6.2	6.6	7.0
2	Full	5.0	11	17	23	31	36	42	48	52	55
	.6 reduced	2.7	5.7	9.0	13	17	20	24	29	30	33
	.4 reduced	1.8	3.8	6.0	8.4	11	13	16	19	20	22
	.2 reduced	.90	1.9	3.0	4.2	5.7	6.5	8.0	9.0	10	11
3	Full	14	30	47	65	88	102	118	136	146	155
	.6 reduced	8.4	18	28	39	53	61	71	81	87	93
	.4 reduced	5.6	12	19	26	35	41	47	54	58	62
	.2 reduced	2.8	5.9	9.3	13	15	21	24	27	29	31
4	Full	24	51	80	112	152	176	202	234	250	266
	.6 reduced	14	30	48	67	90	95	120	140	149	159
	.4 reduced	9.5	20	32	45	60	63	80	93	99	106
	.2 reduced	4.8	10	16	22	30	32	40	47	50	53
6	Full	43	91	144	202	273	316	364	422	451	480
	.6 reduced	26	55	86	120	164	189	219	254	270	288
	.4 reduced	17	37	58	80	109	126	146	169	180	192
	.2 reduced	8.6	18	29	40	55	63	73	85	90	96
8	Full	72	152	240	336	456	528	608	704	752	800
	.6 reduced	43	90	144	201	273	317	365	422	450	480
	.4 reduced	29	60	96	134	182	211	243	281	300	320
	.2 reduced	14	30	48	67	91	106	122	141	150	160

torque specifications

TORQUE REQUIREMENTS TO ACHIEVE ANSI CLASS IV, V OR VI SHUTOFF (Foot Pounds)

Valve Size	Shut off Pressure Drop (PSIG)													
	30	50	100	200	300	400	500	600	700	800	900	1000	1200	1440
1	10.8	11.0	11.5	12.2	12.9	13.8	14.6	15.4	16.2	16.9	17.8	18.6	20.2	21.8
1.5	19.5	19.9	21.2	23.4	25.8	28.0	30.3	32.7	34.9	37.3	39.6	42.4	46.5	51.1
2	28.7	29.5	31.4	35.3	39.3	43.3	47.3	51.3	55.2	59.2	63.1	67.4	74.9	78.8
3	61.3	63.7	69.7	81.7	93.6	106	117	129	142	153	165	177	193	210
4	110	116	130	160	189	218	248	277	306	336	365	394	-	-
6	229	252	299	393	487	582	676	770	-	-	-	-	-	-
8	397	442	552	773	994	-	-	-	-	-	-	-	-	-

MAXIMUM ALLOWABLE DIFFERENTIAL PRESSURE (PSIG)

Based on Torsional Shear Strength of Shaft

Valve Size	Shaft Material
	17-4 SST
1	1440
1.5	1440
2	1440
3	1440
4	1000
6	1000
8	550

MAXIMUM ALLOWABLE SHAFT TORQUES

(Foot Pounds)

Valve Size	Shaft Material
	17-4 SST
1	210
1.5	210
2	210
3	390
4	390
6	1550
8	1550

DIAPHRAGM ACTUATOR OUTPUT TORQUES

Actuator Size	Actuator Action	Actuator Spring	Output Torque(Ft-lbs)
40	Air to Open	20 psi	31
	Air to Close	20 psi	19
	Air to Open	35 psi	58
	Air to Close	35 psi	58
	Air to Open	60 psi	95
	Air to Close	60 psi	102
55	Air to Open	20 psi	88
	Air to Close	20 psi	76
	Air to Open	35 psi	152
	Air to Close	35 psi	124
	Air to Open	60 psi	263
	Air to Close	60 psi	224

Actuator Size	Actuator Action	Actuator Spring	Output Torque(Ft-lbs)
85	Air to Open	20 psi	130
	Air to Close	20 psi	130
	Air to Open	35 psi	220
	Air to Close	35 psi	221
	Air to Open	60 psi	389
	Air to Close	60 psi	389

actuator sizing

Full Port, Air to Open Flow-to-Open & Flow-to-Close

Valve Size (Inches)	Actuator Code	Maximum Shutoff Pressure Differential		
		Air Supply PSIG		
		20	35	60
1	DR-40-R-60	-	-	1440
	DR-40-R-35	-	1440	-
	DR-40-R-20	1440	-	-
1.5	DR-40-R-60	-	-	1440
	DR-40-R-35	-	1440	-
	DR-40-R-20	500	-	-
2	DR-40-R-60	-	-	1440
	DR-40-R-35	-	800	-
	DR-40-R-20	100	-	-
3	DR-55-R-60*	-	-	1440
	DR-55-R-35	-	775	-
	DR-55-R-20	250	-	-
	DR-85-R-35*	-	1440	-
	DR-85-R-20	600	-	-
4	DR-55-R-60*	-	-	540
	DR-55-R-35	-	100	-
	DR-55-R-20	25	-	-
	DR-85-R-35*	-	400	-
	DR-85-R-20	100	-	-
6**	DR-85-R-60	-	-	200
	DR-85-R-35	-	25	-
8**	DR-85-R-60	-	-	25

Full Port, Air to Close Flow-to-Open & Flow-to-Close

Valve Size (Inches)	Actuator Code	Maximum Shutoff Pressure Differential		
		Air Supply PSIG		
		20	35	60
1	DR-40-D-60	-	-	1440
	DR-40-D-35	-	1440	-
	DR-40-D-20	1200	-	-
1.5	DR-40-D-60	-	-	1440
	DR-40-D-35	-	1440	-
	DR-40-D-20	75	-	-
2	DR-40-D-60	-	-	1440
	DR-40-D-35	-	800	-
	DR-40-D-20	20	-	-
3	DR-55-D-60*	-	-	1440
	DR-55-D-35	-	560	-
	DR-55-D-20	150	-	-
	DR-85-D-35*	-	1440	-
	DR-85-D-20	600	-	-
4	DR-55-D-60*	-	-	425
	DR-55-D-35	-	100	-
	DR-55-D-20	20	-	-
	DR-85-D-35*	-	400	-
	DR-85-D-20	100	-	-
6**	DR-85-D-60	-	-	200
	DR-85-D-35	-	25	-
8**	DR-85-D-60	-	-	25

.6, .4 & .2 Reduced Port, Air to Open Flow-to-Open & Flow-to-Close

Valve Size (Inches)	Actuator Code	Maximum Shutoff Pressure Differential		
		Air Supply PSIG		
		20	35	60
1 & 1.5	DR-40-R-60	-	-	1440
	DR-40-R-35	-	1440	-
	DR-40-R-20	1440	-	-
2	DR-40-R-60	-	-	1440
	DR-40-R-35	-	1440	-
	DR-40-R-20	860	-	-
3	DR-55-R-60*	-	-	1440
	DR-55-R-35	-	1440	-
	DR-55-R-20	400	-	-
	DR-85-R-20	960	-	-
4	DR-55-R-60*	-	-	1440
	DR-55-R-35	-	200	-
	DR-55-R-20	40	-	-
	DR-85-R-35*	-	640	-
	DR-85-R-20	160	-	-
6**	DR-85-R-60	-	-	690
	DR-85-R-35	-	120	-
8**	DR-85-R-60	-	-	295

.6, .4 & .2 Reduced Port, Air to Close Flow-to-Open & Flow-to-Close

Valve Size (Inches)	Actuator Code	Maximum Shutoff Pressure Differential		
		Air Supply PSIG		
		20	35	60
1 & 1.5	DR-40-D-60	-	-	1440
	DR-40-D-35	-	1440	-
	DR-40-D-20	1440	-	-
2	DR-40-D-60	-	-	1440
	DR-40-D-35	-	1440	-
	DR-40-D-20	860	-	-
3	DR-55-D-60*	-	-	1440
	DR-55-D-35	-	1440	-
	DR-55-D-20	240	-	-
	DR-85-D-20	960	-	-
4	DR-55-D-60*	-	-	1440
	DR-55-D-35	-	200	-
	DR-55-D-20	30	-	-
	DR-85-D-35*	-	640	-
	DR-85-R-20	160	-	-
6**	DR-85-D-60	-	-	690
	DR-85-D-35	-	120	-
8**	DR-85-D-60	-	-	295

* Not for use with trim material S3.

** For higher differential pressures, consult factory.

ordering code

Class	Material	Valve Size	End Conn.	Valve Rating	Trim Material	Trim Factor	Shutoff Class	Packing	Flow Direction	Actuator	Spring	H.O.D.	Actuator Orientation	# of Accessories	
K	R	C	2	W	1	S	1	4	T	C	B	6	N	2	0
1	2	3	4	5	6	7	8	9	10	11	12	13	14	15	16

Class - Position 1 & 2 KR	Shutoff - Position 9 Classification (per FCI 70.2) 4 = Class IV, Standard 5 = Class V, Optional 6 = Class VI, soft seat only	H = Handwheel J = HandJack
Material - Position 3 C = WCB (Carbon Steel) S = CF8M (Stainless Steel) X = Other	Packing - Position 10 G = Laminated Graphite T = Teflon-Chevron V = Teflon-Chevron ⁴ X = Other	Actuator Orientation - Position 15 A = Standard B = 90° C = 180° D = 270°
Valve Size - Position 4 0 = 1" 1 = 1½" 2 = 2" 3 = 3" 4 = 4" 6 = 6" 8 = 8" X = Other	Flow Direction - Position 11 O = Flow to Open C = Flow to Close	# of Accessories - Position 16 1 = 1 accessory 2 = 2 accessories 3 = 3 accessories 4 = 4 accessories 5 = 5 accessories 6 = 6 accessories 7 = 7 accessories 8 = 8 accessories 9 = 9 accessories 0 = No accessories
End Connection - Position 5 W = Wafer L = CS separable flanges ² S = SS separable flange ¹ F = Integral flanges X = Other	Actuator - Position 12 A = DR-40-D B = DR-40-R C = DR55-D D = DR-55-R E = DR-85-D F = DR-85-R N = None/bare stem ⁵	
Valve Rating - Position 6 1 = ANSI 150 2 = ANSI 300 3 = ANSI 600 4 = ANSI 150 Special Class 5 = ANSI 300 Special Class 6 = ANSI 600 Special Class X = Other	Spring - Position 13 2 = 20 3 = 35 6 = 60 (Standard)	
Trim Material - Position 7 S = Std 316 SS P = Partial Stellite F = Full Stellite R = 316/TFE ⁴ X = Other	H.O.D. - Position 14 N = No	
Trim Factor - Position 8 1 = Full 6 = 0.6 4 = 0.4 2 = 0.2 X = Other		

NOTE: Consult Factory for configurations not listed above.

Add accessories and other options as separate line items.

1. Separable flanges available in 1" - 6", ANSI 150-300 only.
2. Separable flanges available in 1" - 6", ANSI 150-300 only.
Carbon steel separable flanges only good to 800° F service.
3. Optional in 316 & CS valves.
4. Use position 9, Option 6 for shutoff classification. TFE seats 1" - 2" Full Cv only.
5. With Viton O-ring Bearing Seals.
6. Includes Yoke Kit.

applications

The **K-MAX** Rotary Control Valve is engineered to handle nearly all industrial process control requirements including:

- High and Low Pressure Steam
- Clean, Dirty and Corrosive Liquids
- Clean, Dirty and Corrosive Gas
- Erosive and Abrasive Slurries

CONTROL VALVE SPEC SHEET

Project/Job _____
 Unit/Customer _____
 P.O./LCO File # _____
 Item _____
 Contract _____
 MFR Serial# _____

Data Sheet ____ of ____
 Spec _____
 Tag _____
 Dwg _____
 Service _____

Fluid Steam Water Gas

Liquid _____

Crit Pres PC

Service Conditions

Flow #/hr gpm scfh _____

Inlet Pressure psig psia _____

Outlet Pressure psig psia _____

Temperature °C °F _____

Max Press/Temperature: _____ / _____

Density/MW/SG

Viscosity

Vapor Pressure psia _____

Required C_v _____ Noise (dBA) Allowable _____

Max. Flow	Norm. Flow	Min. Flow	Shutoff Pressure

Line Info Pipe Size In _____ /Sch _____ Pipe Size Out _____ /Sch _____

Valve, Body & Bonnet

Body Size in. 1 1½ 2 2½ 3 4 6 8

ANSI Class 150 300 600 Other _____

Body/Bonnet Material: Cast Steel 316SS Other _____

End Conn. Inlet/Outlet: Sep. Flanges Wafer Int. Flanges Other _____

Packing Material: PTFE BTG Laminated Graphite Other _____

Trim Size 100% 60% 40% 20% Other _____

Actuator

Spring Action: Air to Open Air to Close Last Position None

Available Air Supply Pressure: Max. _____ Min. _____

Manual Override: Yes No Type _____

Solenoid Yes No Type _____ Voltage _____

Positioner Yes No Type _____ Pneu I/P

Switch Yes No Type _____

Air Set Yes No Type: _____ Range: _____

Other Accessories Yes No Type _____

Test ANSI/FCI Leakage Class: II III IV V VI Leslie VIII

Since LESLIE CONTROLS was founded in 1900, we have been an industry leader in quality fluid control equipment. We have developed a full line of engineered products to suit your requirements, including diaphragm control valves, control instrumentation, pressure and temperature regulators and steam water heaters.



LESLIE
CONTROLS, INC.

A subsidiary of CIRCOR International, Inc.

12501 Telecom Drive
 Tampa, FL 33637-0906

www.lesliecontrols.com

(813) 978-1000 • FAX: (813) 978-0984