

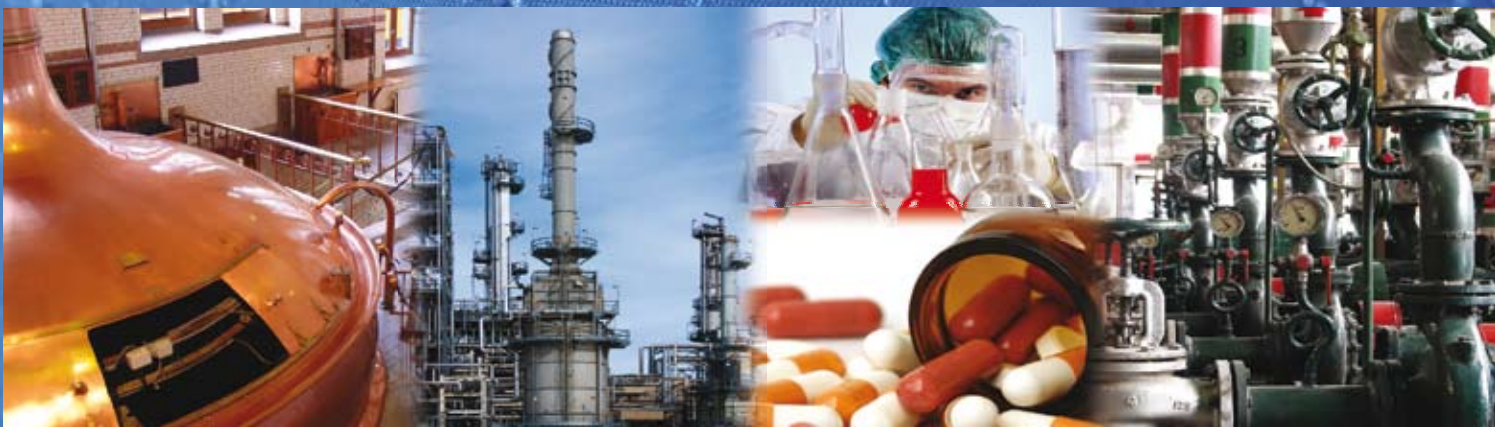

*flow & process solutions*





brands you trust.



STOCKHAM - Ball Valves

**CRANE**

Energy Flow Solutions

# Features & Benefits



## Stockham Ball Valve

### Key Features & Benefits:

- ❶ Full Material Offering: Bronze, Brass, Lead-Free Brass, Carbon Steel and Stainless Steel
- ❷ 100% Factory Testing for Quality Assurance
- ❸ Fully-Rated and Certified

## Figure Number Index

FIG. NO.	PAGE
T-255	4
S-255	5
T-255-FB-P-HC	6
S-255-FB-P-HC	7
T-285	8
S-285	9
T-285-BR-P-66	10
S-285-BR-P-66	11
LF-T-255-FB-P	12
LF-S-255-FB-P	13
T-2852-CS-R-66-LL	14
T-2852-SS-R-66-LL	15

<b>A</b>	
Accessories .....	16
Actuators .....	17
ASME/NSF 61 .....	4, 12, 13
<b>B</b>	
Balancing Plate/Memory Stop .....	16
Body Design .....	3
Brass Body Valves .....	4-7, 12-13
<b>D</b>	
Design .....	3
<b>E</b>	
Extension Stems .....	16
<b>F</b>	
Features & Benefits .....	2
Figure Number System .....	3
Factory Mutual Approved .....	4
<b>H</b>	
Handle Design .....	3
Handle Options .....	16
<b>L</b>	
Lever Lock Handles .....	16
No Lead Brass Valve Offering .....	12-13
<b>M</b>	
Materials .....	3
<b>P</b>	
Pressure/Temperature Ratings .....	18
<b>Q</b>	
Quality Management .....	3
<b>S</b>	
Seat Design .....	3
Stem Design .....	3
<b>T</b>	
Testing .....	3
<b>U</b>	
UL® and CSA® Listed .....	4

# Overview

## APPLICATIONS

Stockham ball valves have gained wide acceptance in industrial and commercial construction segments. Accurate machining and strict testing procedures ensure each user that quality is built into every valve. Stockham ball valves are specified for service in chemical plants, petroleum refineries, pulp and paper mills, and in commercial and industrial construction projects.

## BODY

Stockham offers two-piece body style designs up to 2000# CWP. Two-piece valves offer a larger port opening, equivalent to other competitive options.

Two-piece valves are available in brass (600# CWP), bronze (600# CWP), Stainless Steel (CF8M)(2000# CWP) and Carbon Steel (WCB)(2000# CWP).

Stockham Offers:

2 piece Carbon Steel/Stainless	Threaded to 2"
2 piece Brass valves	Threaded to 4"
2 piece Brass valves	Soldered to 3"
2 piece Bronze valves	NPT & SJ to 3"

## STEM

Stems are inserted from within the body to provide a pressure-safe design (blowout proof).

All Stockham bronze and brass ball valves are furnished with stem seals of PTFE to assure a long lasting, positive seal.

Most valves have gland nuts which may be adjusted for stem seal tightness.

## SEAT

Tight shutoff is achieved with use of PTFE or RTFE seats.

## HANDLE

Handles on threaded and solder end valves are zinc plated carbon steel or stainless steel, covered with a protective plastic sleeve with "Stockham" imprinted on it. Handle stop is an integral part of the handle and provides positive stop as the body stop engages the handle stop. Handles are firmly attached to the stem with jam nuts. Special handles made of Type 304 stainless steel may be furnished on some valves. Other handle options are shown on page 18.

## TESTING

Each valve is individually air-tested to ensure the double-block qualities of the seals and to test the integrity of the pressure-containing parts.

## WEIGHTS AND DIMENSIONS

Published weights and dimensions are for estimating purposes only and are subject to change without notice. It is our intent to maintain basic dimensional requirements of acceptable standards.

## MATERIALS

The standard valve materials for ball valves are brass, bronze, carbon steel, and stainless steel. All materials for ball valves conform to the specifications set by the American Society for Testing and Materials. Changes in materials may be made without notice.

## Figure Number System

Size	Special	Ends	Body Style	Body Material	Seats/Packing	Trim	Handle
1/4" - 4"	LF = No Lead AB 1953 Approved Material	T = Threaded S = Solder Joint	255 = 2 pc. Forged, Full Port 600#	FB = Forged Brass BR = Cast Bronze	P = PTFE (Virgin) R = RTFE (Reinforced)	70 = Chrome Plated Brass Ball 66 = Stainless Ball & Stem HC = Hose Cap & Chain*	Lever
			285 = 2 pc. Cast, Full Port 600#	CS = Carbon Steel SS = Stainless Steel			LL = Locking Lever EL = Extended Lever SL = Stainless Steel Lever
			2852 = 2 pc. Full Port 2000#				

Use this figure number system when ordering ball valves to indicate specific features desired. Not all combinations are available.

\* Hose caps, when provided, are for thread protection and not intended to be used as primary sealing device.

## QUALITY MANAGEMENT

Stockham is committed to a philosophy of total quality management. It begins with design, to comply with pertinent MSS and ASME Standards. Continuous improvement is applied in a methodical process to improve materials and services to meet or exceed customer needs.

# Dimensions 600 CWP/150 SWP • Full Port • Threaded Ends

## T-255

Forged Brass, 2-Piece Body, Meets MSS SP-110,  
CSA/UL/FM Approval (1/2" - 2" only) NSF 61.8 (1/4" - 4")

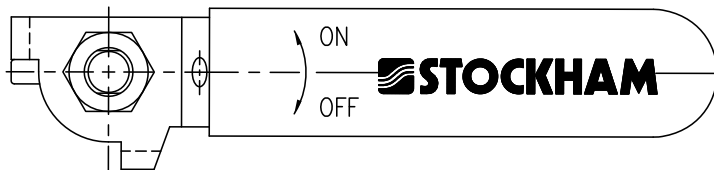
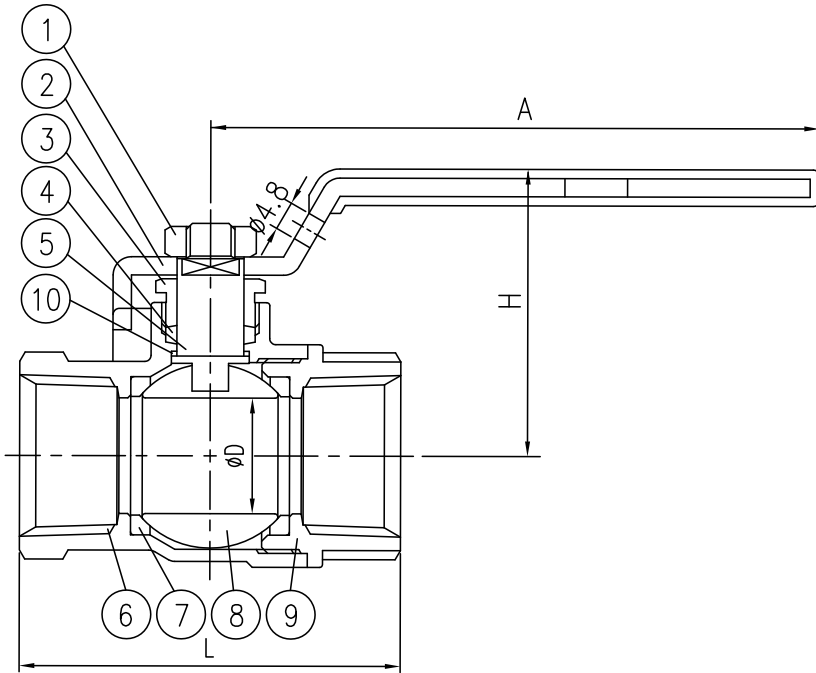

## Materials of Construction

No.	Description	Material
1	Nut	AISI-1010
2	Handle	A283-D
3	Stem Gland Screw	B16-C36000
4	Stem Packing	PTFE
5	Stem	B16-C36000
6	Body	B124-C37700 B584-C85700 (2" - 4")
7	Seat	PTFE
8	Ball	B16-C36000 or B124-C37700 (1" - 4")
9	End Plug	B124-C37700
10	Thrust Washer	PTFE (2" - 4")

For optional Accessories see Page 16.

## Dimensions and Weights

Inches (millimeters) - Pounds (kilograms)

Valve Size	Dimensions				Wt.
	A	D	H	L	
1/4	1.97	0.35	1.26	1.69	0.35
	(50)	(9)	(32)	(43)	(0.16)
3/8	2.95	0.39	1.46	1.81	0.35
	(75)	(10)	(37)	(46)	(0.16)
1/2	2.95	0.50	1.50	2.13	0.42
	(75)	(13)	(38)	(54)	(0.19)
3/4	3.94	0.75	1.85	2.48	0.84
	(100)	(19)	(47)	(63)	(0.38)
1	3.94	0.98	2.05	2.99	1.25
	(100)	(25)	(52)	(76)	(0.57)
1 1/4	4.92	1.25	2.36	3.35	1.83
	(125)	(32)	(60)	(85)	(0.83)
1 1/2	4.92	1.50	2.56	3.62	2.49
	(125)	(38)	(65)	(92)	(1.13)
2	7.87	1.97	3.11	4.25	4.58
	(200)	(50)	(79)	(108)	(2.08)
2 1/2	7.87	2.48	3.50	5.16	7.71
	(200)	(63)	(89)	(131)	(3.50)
3	7.87	2.95	3.86	5.91	10.64
	(200)	(75)	(98)	(150)	(4.83)
4	7.87	3.97	3.86	6.26	13.22
	(200)	(96)	(98)	(159)	(6.00)



MH46785  
Listed  
2L73



### Approvals:

UL Approved

- YSDT (LP-Gas Shut-off valves)
- YRBX (Flammable Liquid Shut-off valves)
- MHKZ (Manual valves)

CSA Approved

- CLASS 3371 94 - Manually Operated Metallic for Use in Piping Systems  
Certified to US Standards
- CLASS 3371 92 - Manually Operated Metallic for Use in House  
Piping Systems - Certified to US Standards
- CLASS 3371 88 - General Use - Certified to US Standards
- CLASS 3371 81 - Appliance Connector - Certified to US Standards
- CLASS 3371 12 - Manually Operated for Use on Piping
- CLASS 3371 10 - Lever Operated Non-Lubricated Shut-off
- CLASS 3371 08 - General Use
- CLASS 3371 01 - Appliance Connector
- CLASS 3371 10
- CLASS 3371 90

# Dimensions 600 CWP/150 SWP • Full Port • Solder Ends

## S-255

Forged Brass, 2-Piece Body

Meets MSS SP-110, NSF 61.8 (1/2" - 3")

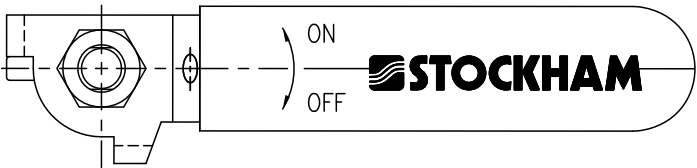
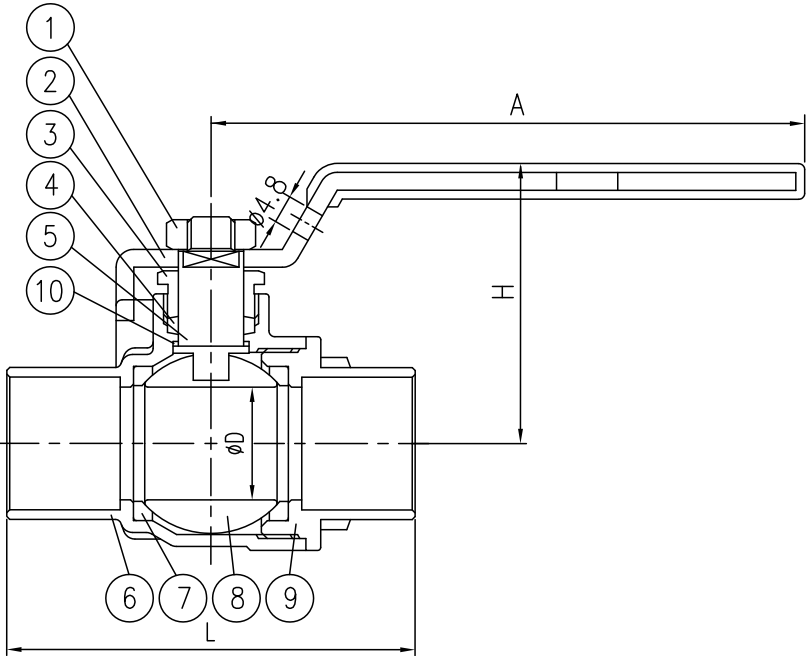

### Materials of Construction

No.	Description	Material
1	Nut	AISI-1010
2	Handle	A283-D
3	Stem Gland Screw	B16-C36000
4	Stem Packing	PTFE
5	Stem	B16-C36000
6	Body	B124-C37700 B584-C85700 (2" - 3")
7	Seat	PTFE
8	Ball	B16-C36000 or B124-C37700 (1" - 3")
9	End Plug	B124-C37700
10	Thrust Washer	PTFE (2" - 3")

For optional Accessories see Page 16.

### Dimensions and Weights

Inches (millimeters) - Pounds (kilograms)

Valve Size	Dimensions				Wt.
	A	D	H	L	
1/2	2.95	0.50	1.50	1.93	0.37
	(75)	(13)	(38)	(49)	(0.17)
3/4	3.94	0.75	1.85	2.72	0.79
	(100)	(19)	(47)	(69)	(0.36)
1	3.94	0.98	2.05	3.31	1.16
	(100)	(25)	(52)	(84)	(0.53)
1 1/4	4.92	1.25	2.36	3.78	1.65
	(125)	(32)	(60)	(96)	(0.75)
1 1/2	4.92	1.50	2.56	4.29	2.20
	(125)	(38)	(65)	(109)	(1.00)
2	7.87	1.97	3.11	5.35	4.40
	(200)	(50)	(79)	(136)	(2.00)
2 1/2	7.87	2.48	3.50	6.18	6.90
	(200)	(63)	(89)	(157)	(3.13)
3	7.87	2.95	3.86	7.09	9.92
	(200)	(75)	(98)	(180)	(4.50)

## Dimensions 600 CWP • Full Port • Threaded Ends

### T-255-FB-P-HC

Forged Brass, Hose Cap and Chain, 2-Piece Body\*  
Meets MSS SP-110

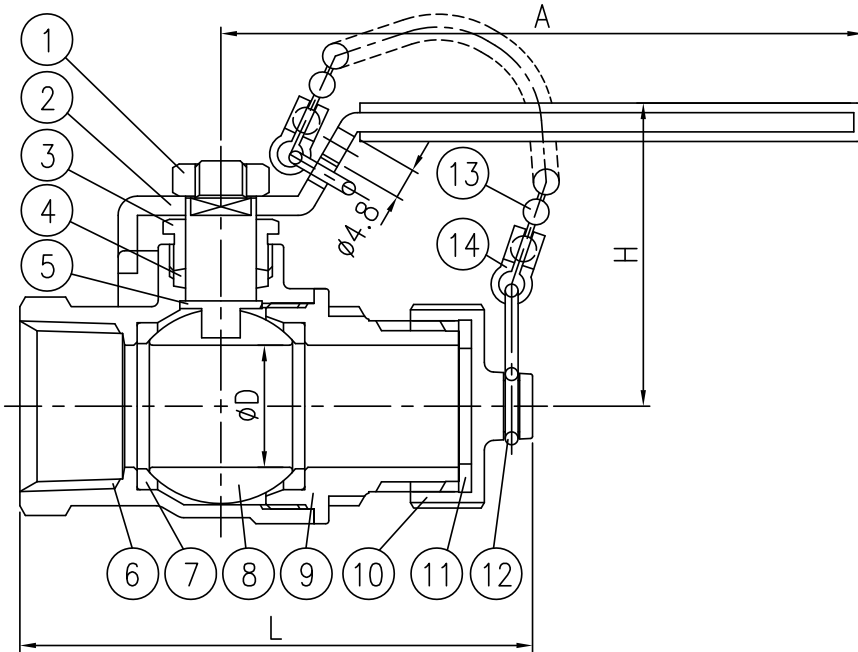

### Materials of Construction

No.	Description	Material
1	Nut	AISI-1010
2	Handle	A283-D
3	Stem Gland Screw	B16-C36000
4	Stem Packing	PTFE
5	Stem	B16-C36000
6	Body	B124-C37700
7	Seat	PTFE
8	Ball Disc	B16-C36000
9	End Plug	B124-C37700
10	Cap Nut	B124-C37700
11	Nut Packing	NBR
12	Ring	A227M
13	Chain	A283-D
14	Plate	A283-D

For optional Accessories see Page 16.

\* Hose caps when provided are for thread protection and not intended to be used as primary sealing device.



### Dimensions and Weights

Inches (millimeters) - Pounds (kilograms)

Valve Size	Dimensions				Wt.
	A	D	H	L	
1/2	2.95	.50	1.50	2.83	0.57
	(75)	(13)	(38)	(72)	(0.26)
3/4	3.94	.75	1.85	3.15	1.03
	(100)	(19)	(47)	(80)	(0.47)

# Dimensions 600 CWP • Full Port • Solder Ends

## S-255-FB-P-HC

Forged Brass, Hose Cap and Chain, 2-Piece Body\*  
Meets MSS SP-110

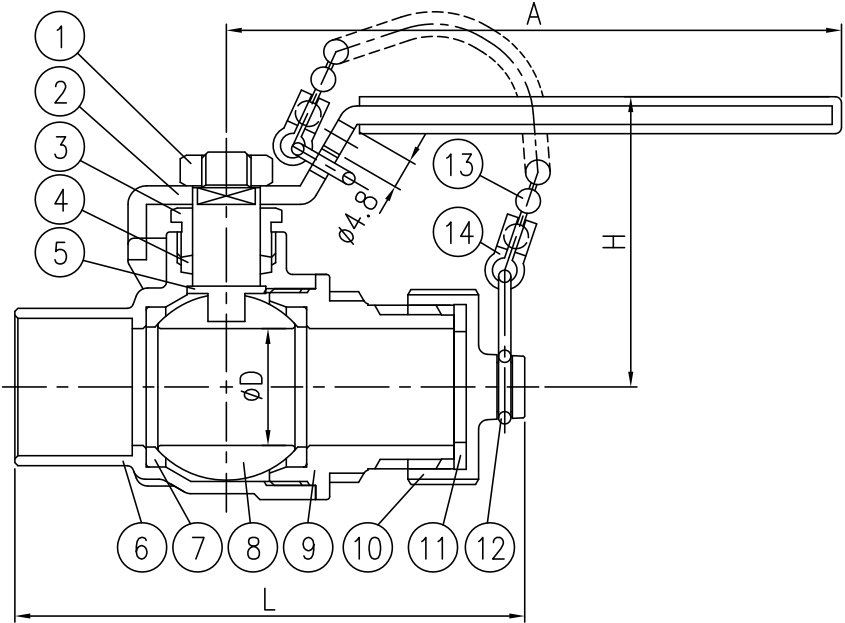

### Materials of Construction

No.	Description	Material
1	Nut	AISI-1010
2	Handle	A283-D
3	Stem Gland Screw	B16-C36000
4	Stem Packing	PTFE
5	Stem	B16-C36000
6	Body	B124-C37700
7	Seat	PTFE
8	Ball Disc	B16-C36000
9	End Plug	B124-C37700
10	Cap Nut	B124-C37700
11	Nut Packing	NBR
12	Ring	A227
13	Chain	A283-D
14	Plate	A283-D

For optional Accessories see Page 16.

\* Hose caps when provided are for thread protection and not intended to be used as primary sealing device.



### Dimensions and Weights

Inches (millimeters) - Pounds (kilograms)

Valve Size	Dimensions				Wt.
	A	D	H	L	
1/2	2.95	.50	1.50	2.71	0.57
	(75)	(13)	(38)	(69)	(0.26)
3/4	3.94	.75	1.85	3.27	0.99
	(100)	(19)	(47)	(83)	(0.45)

# Dimensions 600 CWP/150 SWP • Full Port • Threaded Ends

## T-285

Cast Bronze, 2-Piece Body, Chrome Plated Brass Ball,  
Meets MSS SP-110

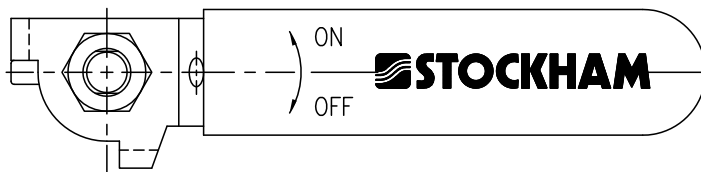
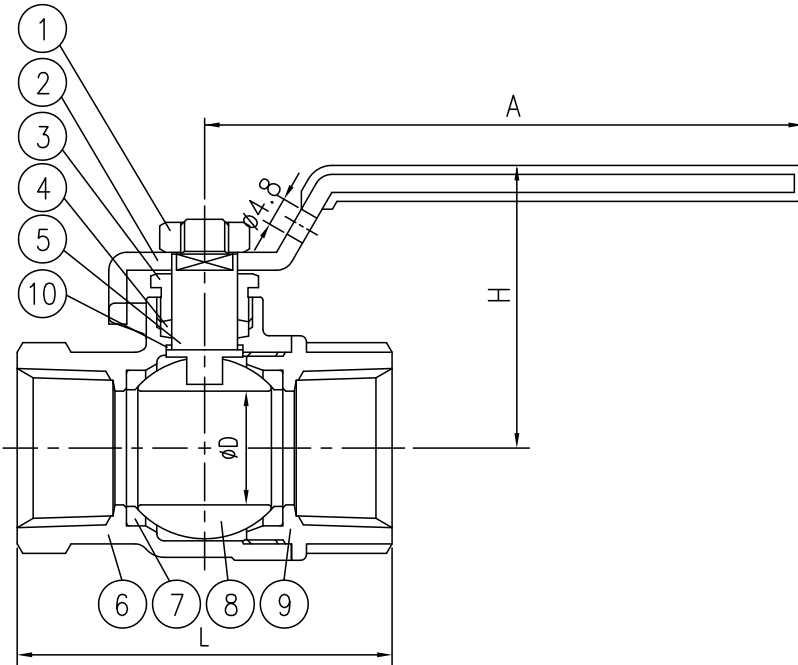

## Materials of Construction

No.	Description	Material
1	Nut	AISI-1010
2	Handle	A283-D
3	Stem Gland Screw	B16-C36000
4	Stem Packing	PTFE
5	Stem	B16-C36000
6	Body	B584-C84400
7	Seat	PTFE
8	Ball	B16-C36000 or B124-C37700 (1" - 3")
9	End Plug	B584-C84400
10	Thrust Washer	PTFE

For optional Accessories see Page 16.

## Dimensions and Weights

Inches (millimeters) - Pounds (kilograms)

Valve Size	Dimensions				Wt.
	A	D	H	L	
1/4	1.97	0.35	1.26	1.69	0.37
	(50)	(9)	(32)	(43)	(0.17)
3/8	2.95	0.39	1.46	1.81	0.31
	(75)	(10)	(37)	(46)	(0.14)
1/2	2.95	0.50	1.50	2.13	0.39
	(75)	(13)	(38)	(54)	(0.18)
3/4	3.94	0.75	1.85	2.48	0.86
	(100)	(19)	(47)	(63)	(0.39)
1	3.94	0.98	2.05	2.99	1.25
	(100)	(25)	(52)	(76)	(0.57)
1 1/4	4.92	1.25	2.36	3.35	1.52
	(125)	(32)	(60)	(85)	(0.69)
1 1/2	4.92	1.50	2.56	3.62	1.83
	(125)	(38)	(65)	(92)	(0.83)
2	7.87	1.97	3.11	4.25	5.51
	(200)	(50)	(79)	(108)	(2.50)
2 1/2	7.87	2.48	3.50	5.16	9.37
	(200)	(63)	(89)	(131)	(4.25)
3	7.87	2.95	3.86	5.91	13.60
	(200)	(75)	(98)	(180)	(6.17)

# Dimensions 600 CWP/150 SWP • Full Port • Solder Ends

## S-285

Cast Bronze, 2-Piece Body, Chrome Plated Brass Ball,  
Meets MSS SP-110

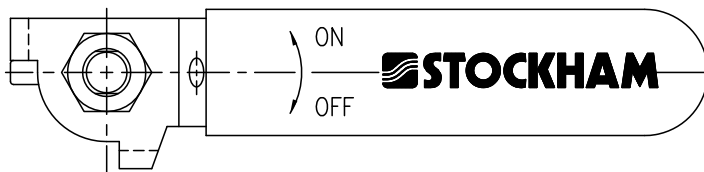
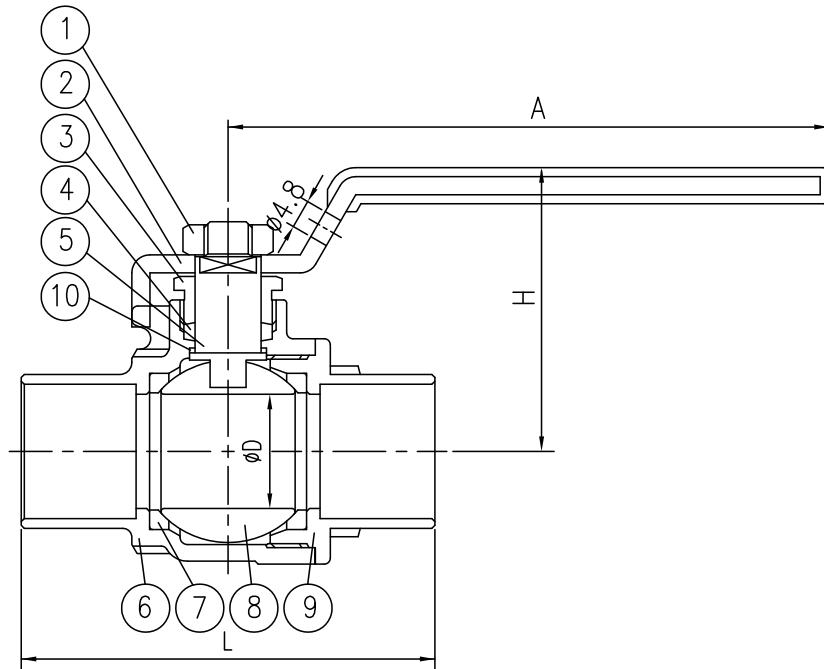

### Materials of Construction

No.	Description	Material
1	Nut	AISI-1010
2	Handle	A283-D
3	Stem Gland Screw	B16-C36000
4	Stem Packing	PTFE
5	Stem	B16-C36000
6	Body	B584-C84400
7	Seat	PTFE
8	Ball	B16-C36000 or B124-C37700 (1" - 3")
9	End Plug	B584-C84400
10	Thrust Washer	PTFE

For optional Accessories see Page 16.

### Dimensions and Weights

Inches (millimeters) - Pounds (kilograms)

Valve Size	Dimensions				Wt.
	A	D	H	L	
3/8	3.31	0.39	1.46	1.61	0.31
	(84)	(10)	(37)	(41)	(0.14)
1/2	3.31	0.50	1.50	1.93	0.39
	(84)	(13)	(38)	(49)	(0.18)
3/4	4.65	0.79	1.93	2.76	0.86
	(118)	(20)	(49)	(70)	(0.39)
1	4.65	0.98	2.09	3.31	1.25
	(118)	(25)	(53)	(84)	(0.57)
1 1/4	5.28	1.25	2.48	3.78	1.52
	(134)	(32)	(63)	(96)	(0.69)
1 1/2	5.28	1.50	2.64	4.29	1.83
	(134)	(38)	(67)	(109)	(0.83)
2	7.87	1.97	3.31	5.39	5.51
	(200)	(50)	(84)	(137)	(2.50)
2 1/2	7.87	2.48	3.66	6.22	9.37
	(200)	(63)	(93)	(158)	(4.25)
3	7.87	2.95	4.02	7.17	13.60
	(200)	(75)	(102)	(182)	(6.17)

## Dimensions 600 CWP/150 SWP • Full Port • Threaded Ends

### T-285-BR-P-66

Cast Bronze, 2-Piece Body, Stainless Steel Ball & Stem,  
Meets MSS SP-110

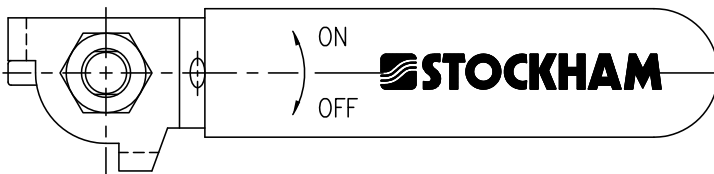
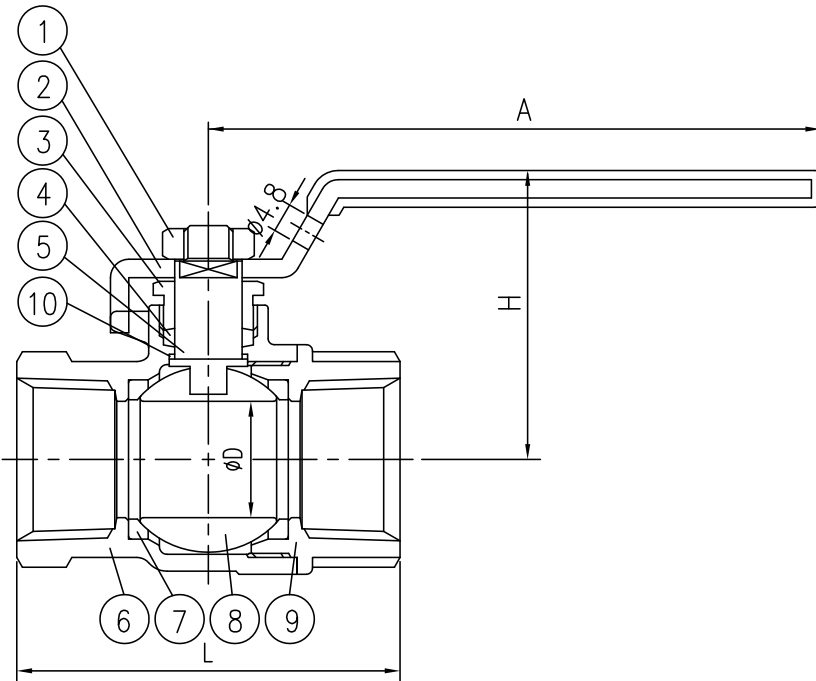

### Materials of Construction

No.	Description	Material
1	Nut	AISI-1010
2	Handle	A283-D
3	Stem Gland Screw	B16-C36000
4	Stem Packing	PTFE
5	Stem	S30400
6	Body	B584-C84400
7	Seat	PTFE
8	Ball	S30400
9	End Plug	B124-C37700
10	Thrust Washer	PTFE

For optional Accessories see Page 16.

### Dimensions and Weights

Inches (millimeters) - Pounds (kilograms)

Valve Size	Dimensions				Wt.
	A	D	H	L	
1/4	1.97	0.35	1.26	1.69	0.42
	(50)	(9)	(32)	(43)	(0.19)
3/8	2.95	0.39	1.46	1.81	0.35
	(75)	(10)	(37)	(46)	(0.16)
1/2	2.95	0.50	1.50	2.13	0.48
	(75)	(13)	(38)	(54)	(0.22)
3/4	3.94	0.75	1.85	2.48	0.88
	(100)	(19)	(47)	(63)	(0.40)
1	3.94	0.98	2.05	2.99	1.27
	(100)	(25)	(52)	(76)	(0.58)
1 1/4	4.92	1.25	2.36	3.35	1.96
	(125)	(32)	(60)	(85)	(0.89)
1 1/2	4.92	1.50	2.56	3.62	2.58
	(125)	(38)	(65)	(92)	(1.17)
2	7.87	1.97	3.11	4.25	5.88
	(200)	(50)	(79)	(108)	(2.67)
2 1/2	7.87	2.48	3.50	5.16	10.20
	(200)	(63)	(89)	(131)	(4.63)
3	7.87	2.95	3.86	5.91	14.33
	(200)	(75)	(98)	(180)	(6.50)

**Dimensions 600 CWP/150 SWP • Full Port • Solder Ends**

**S-285-BR-P-66**

**Cast Bronze, 2-Piece Body, Stainless Steel Ball & Stem,  
Meets MSS SP-110**

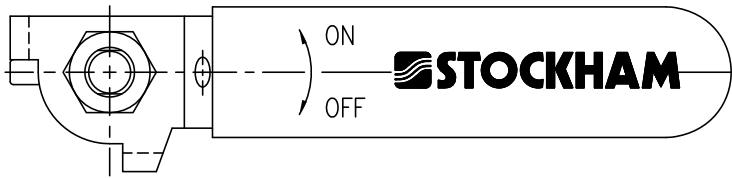
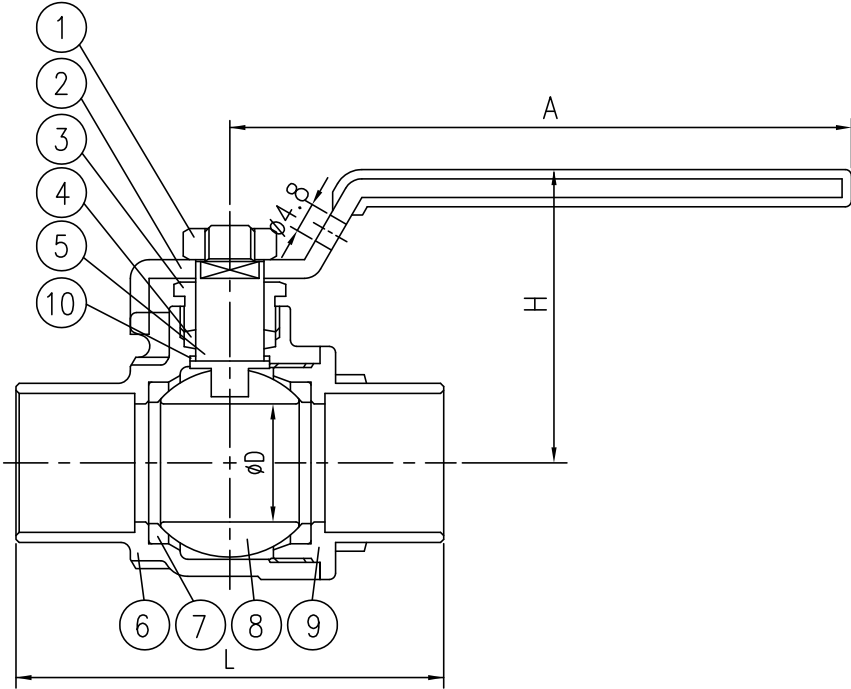

**Materials of Construction**

No.	Description	Material
1	Nut	AISI-1010
2	Handle	A283-D
3	Stem Gland Screw	B16-C36000
4	Stem Packing	PTFE
5	Stem	S30400
6	Body	B584-C84400
7	Seat	PTFE
8	Ball	S30400
9	End Plug	B124-C37700
10	Thrust Washer	PTFE

For optional Accessories see Page 16.

**Dimensions and Weights**

Inches (millimeters) - Pounds (kilograms)

Valve Size	Dimensions				Wt.
	A	D	H	L	
3/8	3.31	0.39	1.46	1.61	0.28
	(84)	(10)	(37)	(41)	(0.13)
1/2	3.31	0.50	1.50	1.93	0.39
	(84)	(13)	(38)	(49)	(0.18)
3/4	4.65	0.79	1.93	2.76	0.88
	(118)	(20)	(49)	(70)	(0.40)
1	4.65	0.98	2.09	3.31	1.27
	(118)	(25)	(53)	(84)	(0.58)
1 1/4	5.28	1.25	2.48	3.78	2.02
	(134)	(32)	(63)	(96)	(0.92)
1 1/2	5.28	1.50	2.64	4.29	2.29
	(134)	(38)	(67)	(109)	(1.04)
2	7.87	1.97	3.31	5.39	5.40
	(200)	(50)	(84)	(137)	(2.45)
2 1/2	7.87	2.48	3.66	6.22	8.48
	(200)	(63)	(93)	(158)	(3.85)
3	7.87	2.95	4.02	7.17	12.34
	(200)	(75)	(102)	(182)	(5.60)

## Dimensions 600 CWP • Full Port • Threaded Ends

### LF-T-255-FB-P

Forged No Lead Brass, 2-Piece Body, NSF-61-G & AB 1953

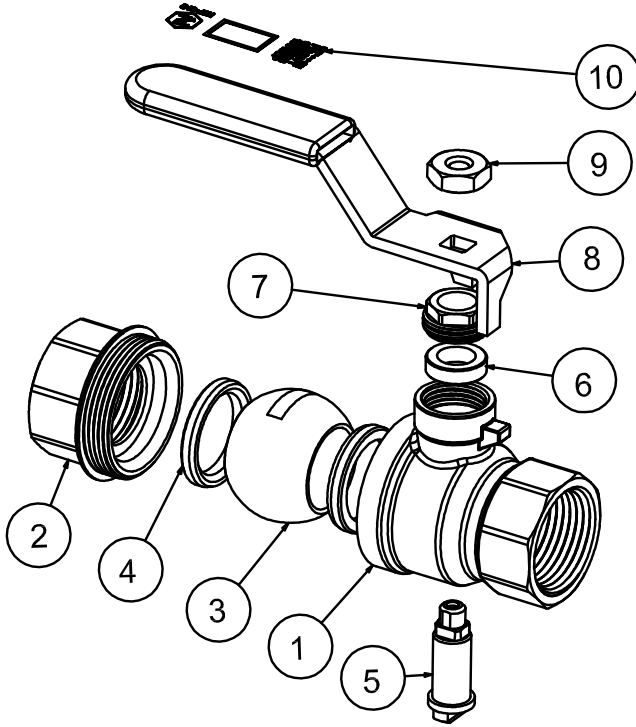

### Materials of Construction

No.	Description	Material
1	Body	AB 1953 Brass OT57
2	Fixed End	AB 1953 Brass OT57
3	Ball	Chromium Plated AB 1953 Brass OT57
4	Seat	PTFE
5	Stem	AB 1953 Brass OT57
6	Packing Ring	PTFE
7	Packing Nut	Brass ASTM B124 C37700
8	Handle	Steel ASTM A36 Dacromet Plated
9	Nut	Steel ASTM A36 Zinc Plated
10	Print	Black Color

For optional Accessories see Page 16.

**Valves are rated to 600CWP only and are not intended for use on steam service.**

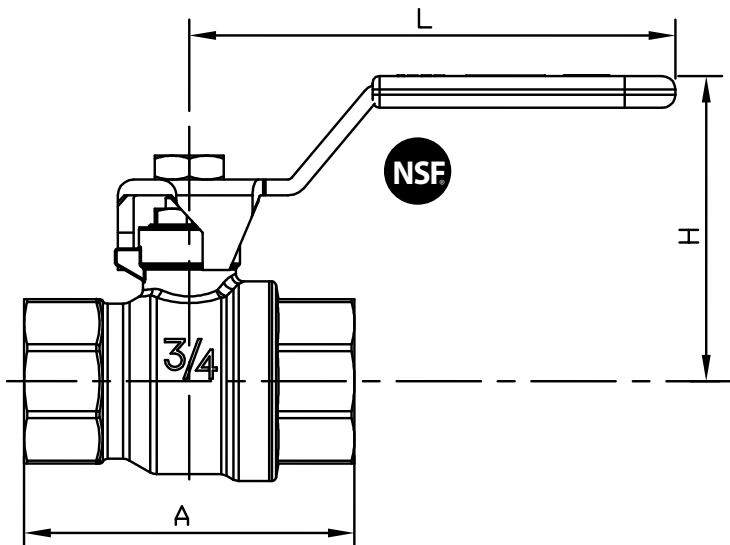

### Dimensions and Weights

Inches (millimeters) - Pounds (kilograms)

Valve Size	Dimensions			Wt.
	A	H	L	
1/2	2.12	2.11	3.60	0.46
	(54)	(54)	(91)	(.21)
3/4	2.44	2.26	3.60	0.64
	(62)	(57)	(91)	(.29)
1	2.85	2.60	4.98	1.04
	(72)	(66)	(126)	(.47)
1 1/4	3.27	2.85	4.98	1.65
	(83)	(72)	(126)	(.75)
1 1/2	3.79	3.23	5.59	2.38
	(96)	(82)	(142)	(1.08)
2	4.35	3.52	5.59	3.64
	(110)	(89)	(142)	(1.65)

## Dimensions 600 CWP • Full Port • Solder Ends

### LF-S-255-FB-P

Forged No Lead Brass, 2-Piece Body, NSF-61-G & AB 1953

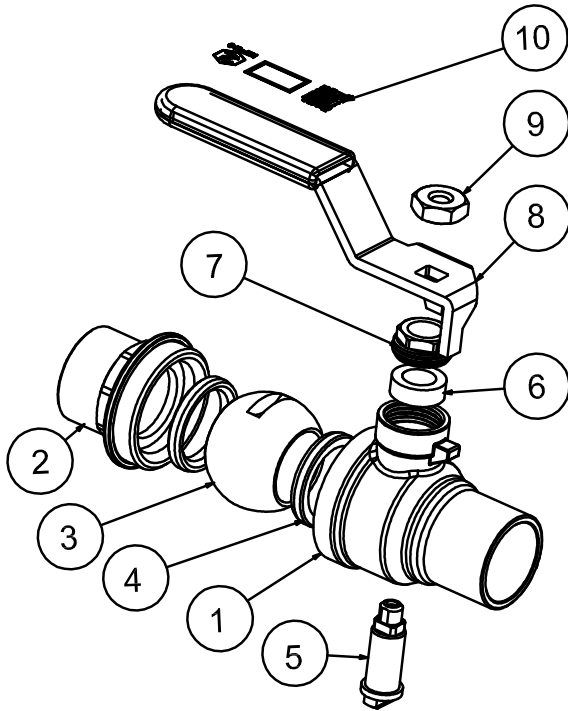

### Materials of Construction

No.	Description	Material
1	Body	AB 1953 Brass OT57
2	Fixed End	AB 1953 Brass OT57
3	Ball	Chromium Plated AB 1953 Brass OT57
4	Seat	PTFE
5	Stem	AB 1953 Brass OT57
6	Packing Ring	PTFE
7	Packing Nut	Brass ASTM B124 C37700
8	Handle	Steel ASTM A36 Dacromet Plated
9	Nut	Steel ASTM A36 Zinc Plated
10	Print	Black Color

For optional Accessories see Page 16.

**Valves are rated to 600CWP only and are not intended for use on steam service.**

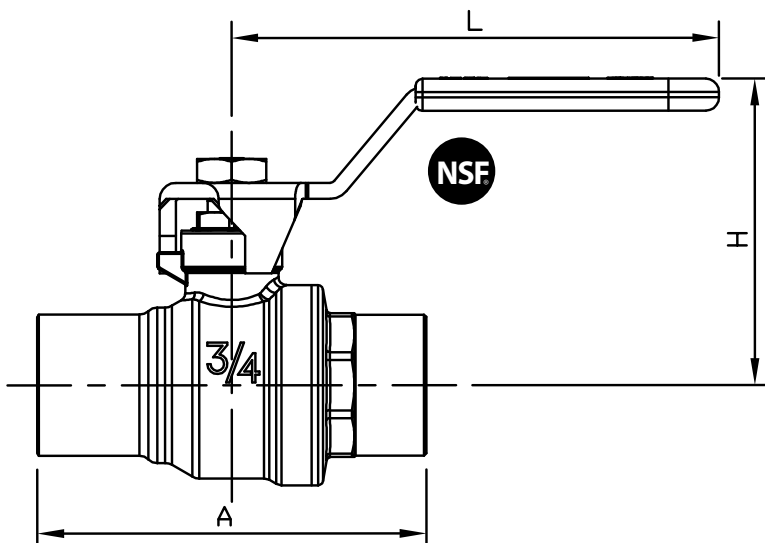

### Dimensions and Weights

Inches (millimeters) - Pounds (kilograms)

Valve Size	Dimensions			Wt.
	A	H	L	
1/2	2.13	2.11	3.60	0.44
	(54)	(54)	(91)	(.20)
3/4	2.87	2.26	3.60	0.60
	(73)	(57)	(91)	(.27)
1	3.39	2.60	4.98	.97
	(86)	(66)	(126)	(.44)
1 1/4	3.90	2.85	4.98	1.41
	(99)	(72)	(126)	(.64)
1 1/2	4.53	3.23	5.59	2.36
	(115)	(82)	(142)	(1.07)
2	5.51	3.52	5.59	3.35
	(140)	(89)	(142)	(1.52)

# Dimensions 2000 CWP • Full Port • Threaded Ends

## T-2852-CS-R-66-LL

Carbon Steel, 2-Piece Body, Stainless Steel Ball & Stem, Locking Lever, Meets MSS SP-110

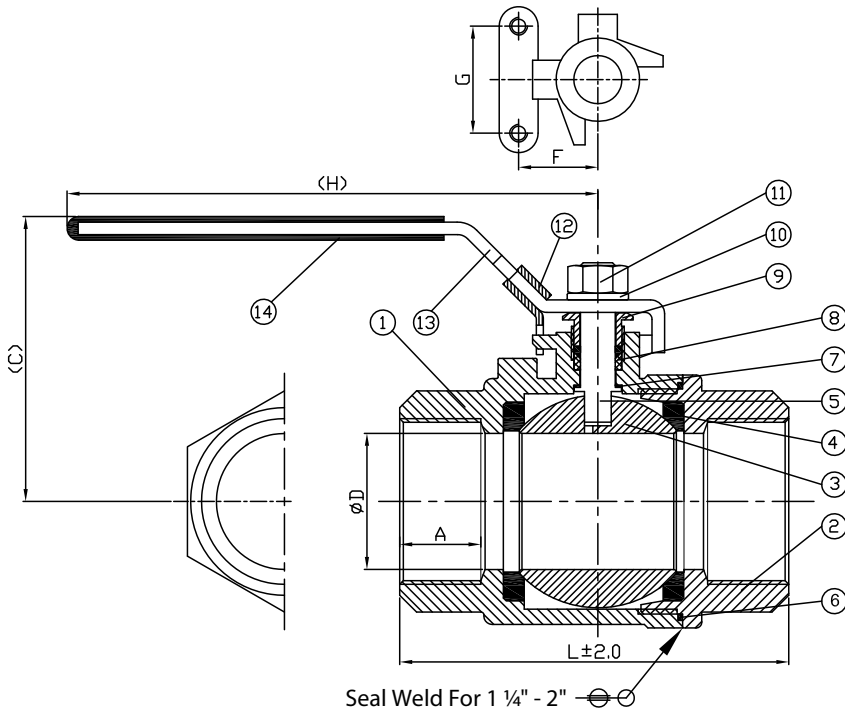

## Materials of Construction

No.	Description	Material
1	Body	WCB
2	Cap	WCB
3*	Ball (Vented)	CF8M
4	Seat	RTFE - PTFE 15% GF
5	Stem	AISI 316
6	Body Seal	PTFE (for 1/4" - 1")
7	Thrust Washer	PTFE
8	Stem Packing	PTFE
9	Gland Nuts	A2
10	Spring Washer	AISI 304
11	Handle Nuts	A2
12	Locking Device	AISI 304
13	Handle	AISI 304
14	Handle Sleeve	PVC

\* All carbon and stainless ball valves come standard with a stainless steel ball.

For optional Accessories see Page 16.

## Dimensions and Weights

Inches (millimeters) - Pounds (kilograms)  
Pound-Force Foot (Newton Meter)

Valve Size	Dimensions							Wt.	Torque	C <sub>v</sub> Factor
	D	L	C	H	F	G	A			
1/4	.45	2.38	2.17	4.13	.50	1.12	.49	.66	3	6.6
	(12)	(61)	(55)	(105)	(13)	(29)	(13)	(.30)	(4)	
3/8	.49	2.38	2.17	4.13	.50	1.12	.55	.66	5	7.9
	(13)	(61)	(55)	(105)	(13)	(29)	(14)	(.30)	(6)	
1/2	.59	2.38	2.24	4.13	.50	1.12	.70	.88	6	11.2
	(15)	(61)	(57)	(105)	(13)	(29)	(18)	(.40)	(8)	
3/4	.79	3.03	2.68	4.84	.87	1.38	.75	1.32	9	21
	(20)	(77)	(68)	(123)	(22)	(35)	(19)	(.60)	(12)	
1	.98	3.54	2.87	6.10	.87	1.38	.89	2.09	11	35
	(25)	(90)	(73)	(155)	(22)	(35)	(23)	(.95)	(15)	
1 1/4	1.26	3.94	3.35	6.10	.93	1.50	.98	3.2	19	57
	(32)	(100)	(85)	(155)	(24)	(38)	(25)	(1.45)	(25)	
1 1/2	1.50	4.65	3.82	7.52	.93	1.50	.98	4.96	26	80
	(38)	(118)	(97)	(191)	(24)	(38)	(25)	(2.25)	(35)	
2	1.93	5.43	4.09	7.52	1.14	1.50	1.15	7.28	34	150
	(49)	(138)	(104)	(191)	(29)	(38)	(29)	(3.30)	(45)	

# Dimensions 2000 CWP • Full Port • Threaded Ends

## T-2852-SS-R-66-LL

**Stainless Steel, 2-Piece Body, Stainless Steel Ball & Stem, Locking Lever, Meets MSS SP-110**

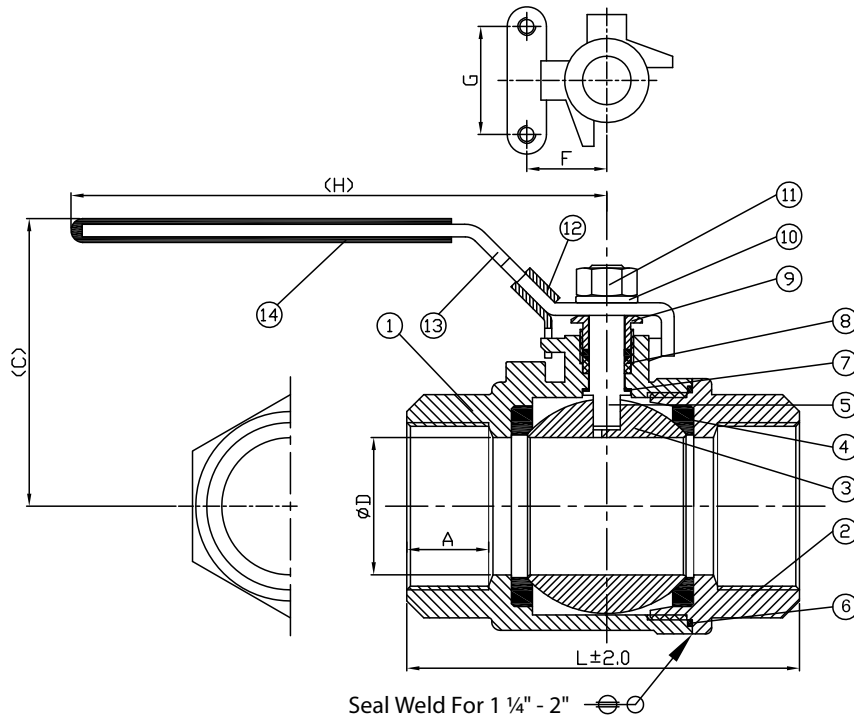

### Materials of Construction

No.	Description	Material
1	Body	CF8M
2	Cap	CF8M
3*	Ball (Vented)	CF8M
4	Seat	RTFE - PTFE 15% GF
5	Stem	AISI 316
6	Body Seal	PTFE (for 1/4" - 1")
7	Thrust Washer	PTFE
8	Stem Packing	PTFE
9	Gland Nuts	A2
10	Spring Washer	AISI 304
11	Handle Nuts	A2
12	Locking Device	AISI 304
13	Handle	AISI 304
14	Handle Sleeve	PVC

\* All carbon and stainless ball valves come standard with a stainless steel ball.

For optional Accessories see Page 16.

### Dimensions and Weights

Inches (millimeters) - Pounds (kilograms)  
Pound-Force Foot (Newton Meter)

Valve Size	Dimensions							Wt.	Torque	C <sub>v</sub> Factor
	D	L	C	H	F	G	A			
1/4	.45	1.97	2.17	4.13	.50	1.12	.49	.66	3	6.6
	(12)	(50)	(55)	(105)	(13)	(29)	(13)	(.30)	(4)	
3/8	.49	2.36	2.17	4.13	.50	1.12	.55	.66	5	7.9
	(13)	(60)	(55)	(105)	(13)	(29)	(14)	(.30)	(6)	
1/2	.59	2.95	2.24	4.13	.50	1.12	.70	.88	6	11.2
	(15)	(75)	(57)	(105)	(13)	(29)	(18)	(.40)	(8)	
3/4	.79	3.15	2.68	4.84	.87	1.38	.75	1.32	9	21
	(20)	(80)	(68)	(123)	(22)	(35)	(19)	(.60)	(12)	
1	.98	3.54	2.87	6.10	.87	1.38	.89	2.09	11	35
	(25)	(90)	(73)	(155)	(22)	(35)	(23)	(.95)	(15)	
1 1/4	1.26	4.33	3.35	6.10	.93	1.50	.98	3.2	19	57
	(32)	(110)	(85)	(155)	(24)	(38)	(25)	(1.45)	(25)	
1 1/2	1.50	4.72	3.82	7.52	.93	1.50	.98	4.96	26	80
	(38)	(120)	(97)	(191)	(24)	(38)	(25)	(2.25)	(35)	
2	1.93	5.51	4.09	7.52	1.14	1.50	1.15	7.28	34	150
	(49)	(140)	(104)	(191)	(29)	(38)	(29)	(3.30)	(45)	

# Accessories



### Extension Stems

Extension stems may be needed when ball valves are installed in piping requiring insulation or in other special circumstances.

### Memory Stop

Continuous operation of a ball valve in partially open position is not recommended. Stockham does not recommend that a ball valve be used in a position less than 50% full open.

### Lever Lock Handles

Lever Lock handles are suitable for use on Lever Lock ball valves. They can be latched for maintenance or operation lockout or for low security protection. Valves may be locked in open and closed positions. Available only in brass as an accessory. Other handle options (not shown): Stainless Steel Handles.

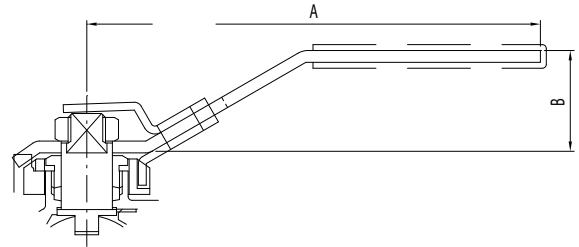
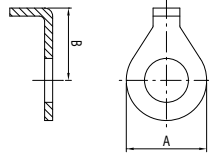
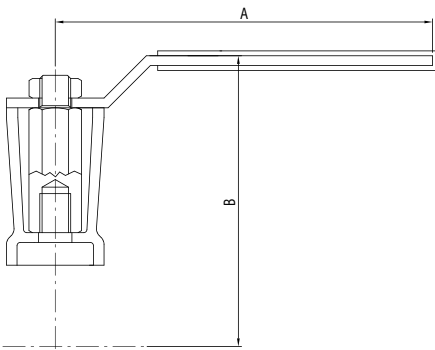

**2 1/4" Extension Stems Dimensions**  
Inches (millimeters)

Valve Size	Dimensions	
	A	B
1/4	3.30	4.37
	(84)	(111)
3/8	3.30	4.37
	(84)	(111)
1/2	3.30	4.40
	(84)	(112)
3/4	4.64	4.88
	(118)	(124)
1	4.64	5.03
	(118)	(128)
1 1/4	5.27	5.47
	(134)	(139)
1 1/2	5.27	5.62
	(134)	(143)
2	7.87	6.25
	(200)	(159)
2 1/2	7.87	6.65
	(200)	(169)
3	7.87	6.96
	(200)	(177)

Available for valves: T-255, S-255, LFT-255, LFS-255, T-285, S-285

**Memory Stop Dimensions**  
Inches (millimeters)

Valve Size	Dimensions	
	A	B
1/4	.59	.55
	(15)	(14)
3/8	.59	.55
	(15)	(14)
1/2	.59	.55
	(15)	(14)
3/4	.74	.66
	(19)	(17)
1	.74	.66
	(19)	(17)
1 1/4	.90	.78
	(23)	(20)
1 1/2	.90	.78
	(23)	(20)
2	1.25	1.10
	(32)	(28)
2 1/2	1.25	1.10
	(32)	(28)
3	1.25	1.10
	(32)	(28)

Available for valves: T-255, S-255, T-285, S-285

**Lever Lock Handles Dimensions**  
Inches (millimeters)

Valve Size	Dimensions	
	A	B
1/4	3.22	.78
	(82)	(20)
3/8	3.22	.78
	(82)	(20)
1/2	3.22	.78
	(82)	(20)
3/4	4.52	1.02
	(115)	(26)
1	4.52	1.02
	(115)	(26)
1 1/4	5.19	1.02
	(132)	(26)
1 1/2	5.19	1.02
	(132)	(26)
2	7.55	.94
	(192)	(24)
2 1/2	7.55	.94
	(192)	(24)
3	7.55	.94
	(192)	(24)

Available for valves: T-255, S-255

# Actuators

## Actuators

Stockham ball valves can be supplied with pneumatic or electric actuators. Valves with pads for simplified mounting include:

½" through 2"      Carbon or Stainless Steel Body  
2-Piece Ball Valves



**For Threaded End Valves, ¼" - 4"**

### Electric

- **Standard** - 120 VAC, 60Hz, single phase, reversing motor; thermal overload protection; manual override, 100% duty cycle; rated torques from 347 to 868 in-lbs.

### To order, please supply the following information:

1. Valve figure number and size
2. Line pressure
3. Electrical supply
4. NEMA Code requirements
5. Special requirements

### Pneumatic

- Models provide 61 to 71,687 in-lbs. of torque with 80 psi supply air.
- Models for fail-safe applications provide output torques from 20 to 67,356 in-lbs. with 80 psi supply air.
- Include solenoid valves (direct mounted) and limit switches.

### To order, please supply the following information:

1. Valve figure number and size
2. Line pressure
3. Air supply pressure (minimum)
4. Double-Acting or Spring Return
5. If spring return, indicate fail-open or fail-close
6. Require limit switches or solenoid valve

# Pressure/Temperature Ratings

The Pressure/Temperature ratings for ball valves are as shown in the charts below.

**T-255, S-255 and T-285, S-285**

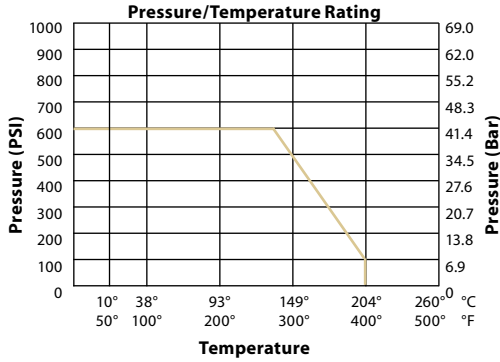

**T-255-FB-P-HC and S-255-FB-P-HC**

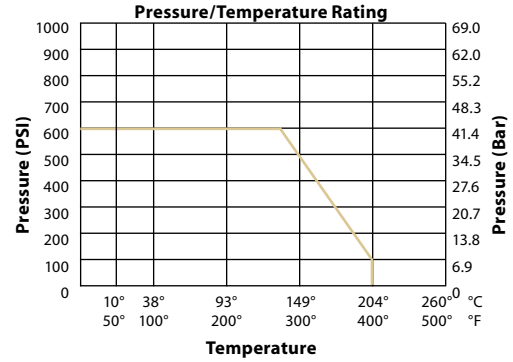

**LF-T-255-FB-P and LF-S-255-FB-P**

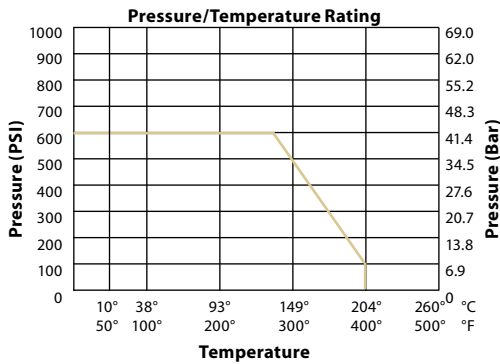

**T-2852-CS-R-66-LL and T-2852-SS-R-66-LL**

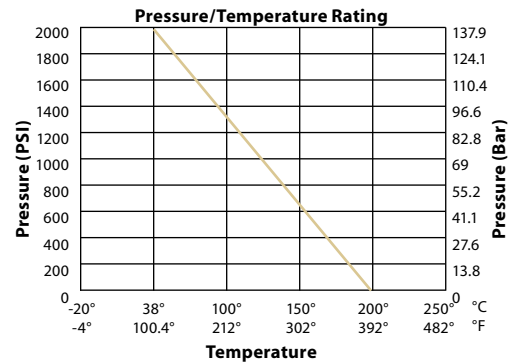





**CRANE**

Energy Flow Solutions



brands you trust.



COMPAC-NOZ

**CRANE**

**DUO-CHEK**



**NOZ-CHEK**



**STOCKHAM**



**UNI-CHEK**

**NUCLEAR**

**VALVE SERVICES**



Potravinářský průmysl  
Farmaceutický průmysl  
Biotechnologie  
Petrochemie  
Chemický průmysl  
Energetika  
Úprava vody  
Papírenství a zpracování celulózy  
Plynárenský průmysl  
Keramický průmysl  
Zpracovatelský průmysl



Firma s tradicí od r. 1990 se při svém vzniku zaměřila na dodávky základních komponent, přístrojové a měřicí techniky a dodávky technologií pro farmaceutický a potravinářský průmysl. Cílem bylo zajistit kompletní dodavatelsko - inženýrské služby, včetně servisu. V roce 1998, který byl pro firmu velmi významným mezníkem, proběhla transformace společnosti do nynější formy. V dalších letech činnosti společnosti dochází k rozšíření portfolia a je navazována spolupráce s partnery v oblasti armatur, komponent, ventilů, procesní měřicí techniky a čerpadel.

Oblastí působnosti je potravinářský, farmaceutický průmysl, biotechnologie, chemický průmysl, petrochemie, úprava vody, papírenství a celulóza, energetika, keramický průmysl a zpracovatelský průmysl.

Firma REGOM INSTRUMENTS je díky širokému dodavatelskému portfoliu a bohatým zkušenostem schopna zajistit dodávky armatur, komponent, čerpadel, přístrojů a zařízení.

Cílem společnosti REGOM INSTRUMENTS je poskytování kvalitních služeb a spolehlivých dodávek pro co nejširší okruh zákazníků.



**REGOM INSTRUMENTS s.r.o.**

Brabcova 1159 / 2

147 00 Praha 4

CZECH REPUBLIC

Tel: +420 241 402 206

Fax: +420 241 400 290

Mail: [regom@regom.cz](mailto:regom@regom.cz)

Skype: regom-office

**[www.regom.cz](http://www.regom.cz)**