



flow & process solutions





brands you trust.



STOCKHAM - Bronze Valves

CRANE

Energy Flow Solutions

The Stockham Pledge

SETTING THE STANDARD IN SERVICE

Stockham is committed to setting the standard in quality service to the Commercial Construction industry.

Our pledge to our customers is:

- A friendly voice every time you call
- Quick response to your quotes and questions
- On-time delivery
- Accurate shipments

Figure Number Index

GLOBE/ANGLE VALVES	
FIG. NO.	PAGE
B-13T	10
B-14T	11
B-16	12
B-17	13
B-20T	15
B-22T	16
B-29	18
B-32T	19
B-37	20
B-62	21
B-64	22
B-66	24
B-74	26
B-220	14
B-222T	17
B-264	23
B-266	25
B-274	27

GATE VALVES	
FIG. NO.	PAGE
B-100	28
B-103	30
B-104	31
B-105	32
B-108	29
B-120	33
B-122	34
B-128	35
B-131	36
B-132	37
B-135	38
B-144	39
B-145	40
B-147	41
LFB-103	58
LFB-104	59

CHECK VALVES	
FIG. NO.	PAGE
B-309Y	47
B-310BY	42
B-310TY	43
B-316	49
B-319Y	48
B-320BY	44
B-320TY	45
B-320BC/TC/VC	46
B-321	52
B-322B	50
B-322T	51
B-337	53
B-345	54
B-367	56
B-375	55
LFB-309Y	60
LFB-319Y	61

NOTE: Add "K" to figure numbers above to designate valves assembled and tested in the USA. For example, B-100K, B-309YK, etc.

Index

General Information	6-9
Globe and Angle Valves	
Class 125 / 200 CWP	10-13
Class 150 / 300 CWP	14-18
Class 200	19-23
Class 300	24-27
Gate Valves	
Class 125 / 200 CWP	28-32
Class 150 / 300 CWP	33-36
Class 200	37-38
Class 300	39-41
Check Valves	
Class 125 / 200 CWP	42-49
Class 150 / 300 CWP	50-52
Class 200	53-54
Class 300	55-56
Bronze Low Lead Valves	
Gate Valves	
Class 125 / 200 CWP	58-59
Swing Check Valves	
Class 125 / 200 CWP	60-61

Cross Reference for Commonly Used Valves

BRONZE

GLOBE

	<u>Stockham</u>	<u>NIBCO</u>	<u>Milwaukee</u>
Class 125	B-16	T-211-B	502
Class 300 SS Trim	B-74 B-66	T-276AP T-275-B	593A 572

GATE

	<u>Stockham</u>	<u>NIBCO</u>	<u>Milwaukee</u>
Class 125 RS-Thread	B-100	T-111	148
Class 125 NRS-Thread	B-103	T-113	105
Class 125 RS-Solder	B-108	S-111	149
Class 125 NRS-Solder	B-104	S-113	115
Class 150 Union Bonnet	B-120	T-134	1151
Class 300 SS Trim	B-145	T-174-SS	1184

CHECK

	<u>Stockham</u>	<u>NIBCO</u>	<u>Milwaukee</u>
Class 125 Thread	B-319Y	T-413-BY	509
Class 125 Solder	B-309Y	S-413-B	1509
Class 300 Swing Check	B-375 B-321	T-473-B T-433-B	507 515

IRON

GATE

	<u>Stockham</u>	<u>NIBCO</u>	<u>Milwaukee</u>	<u>Powell</u>	<u>Walworth</u>
Class 125 NRS	G-612	F-619	F2882 A	1787	W719F
Class 125 OS&Y	G-623	F-617-0	F2885 A	1793	W726F
Class 250 OS&Y	F-667	F-667-0	F2894 A	1797	W786F

GLOBE

	<u>Stockham</u>	<u>NIBCO</u>	<u>Milwaukee</u>	<u>Powell</u>	<u>Walworth</u>
Class 125	G-512	F-718-B	F2981 A	241	W906F

SWING CHECK

	<u>Stockham</u>	<u>NIBCO</u>	<u>Milwaukee</u>	<u>Powell</u>	<u>Walworth</u>
Class 125 Flanged	G-931	F-918-B	F2974 A	559	W928F

STOP CHECK

	<u>Stockham</u>	<u>NIBCO</u>	<u>Milwaukee</u>	<u>Powell</u>	<u>Walworth</u>
Class 250 Straight-way Y-Pattern	F-540	----	----	----	----
Class 250 Angle Y-Pattern	F-541	F-869-B	----	----	----

Pressure-Temperature Ratings

Stockham bronze valves have been specified, installed, and are proven performers in commercial and industrial facilities internationally. The broadness and unsurpassed quality of the Stockham line appeal to consulting engineers, mechanical contractors, and industrial users alike.

QUALITY MANAGEMENT

Stockham is committed to a philosophy of total quality management. It begins with design, to comply with pertinent MSS and ASME Standards. Continuous improvement is applied in a process to improve materials and services to meet or exceed customer needs.

MATERIALS

The basic bronze pressure-containing parts conform to either the American Society for Testing and Materials Specifications B-61 or B-62. Materials for most valve parts are listed in this catalog section. Changes in materials may be made without notice.

PRESSURE-TEMPERATURE RATINGS, NONSHOCK

The pressure classes available have these rated working pressures:

Press. Class	PRESSURE-PSI					
	125	150		200	300	
End Conn.	THD	THD	FLG	THD	THD	FLG
Temp. (Deg. F)	MATERIAL					
	ASTM B-62			ASTM B-61		
-20 to						
150	200	300	225	400	1000	500
200	185	270	210	375	920	475
250	170	240	195	350	830	450
300	155	210	180	325	740	425
350	155	210	165	300	650	400
400	-	-	-	275	560	375
406	125	150	150	-	-	-
450	120	145	-	250	480	350
500	-	-	-	225	390	325
550	-	-	-	200	300	300

NOTES:

- Buna-N Disc Valves limited to 150°F temperatures.
- PTFE and Viton® Disc Valves are limited to 450°F temperatures.
- For lower temperatures, Pressures for Temperatures -20 to 150 shall apply - Uses for low temperatures shall conform to the rules of Applicable Codes under which they are to be used.
- P-T Ratings-ASME B16.24-1971.
- Some codes (i.e. ASME BPVC, Section 1) limit the rating temperatures of B-62 material to 406°F.
- Solder End Valves are limited by temperatures which affect the strength of the solder joint. These ratings must be adjusted as below.
- Internal pressures great enough to burst castings can be developed during the formation of ice. Valves should be protected so that contained media does not freeze.
- Class 300 Valves, 2 ½" and 3" are rated by MSS SP-80 to 600 psi CWP maximum including B-375 bronze check valve.
- Class 200 & 300 valves made of ASTM B62 are limited to 450°F.

ADJUSTED PRESSURE RATINGS

Joints made of Copper Tube and Solder End Valves
(Pounds per square inch)
Extracted from MSS SP-80

SOLDER USED IN JOINTS	SERVICE TEMPERATURE DEGREES F	WATER, including other non-corrosive liquids and gases			SATURATED STEAM (psig)
		Valve Sizes			Valve Sizes
		¼" through 1"	1 ¼" through 2"	2 ½" through 4"	¼" through 4"
50-50 Tin-Lead (ASTM B-32, Alloy Grade 50-A)	100	200	175	150	-
	150	150	125	100	-
	200	100	90	75	-
	250	85	75	50	15
95-5 Tin-Antimony	100	500	400	300	-
	150	400	350	275	-
	200	300	250	200	-
	250	200	175	150	15

Design: Gate, Globe & Angle Valves Classes 125 - 300

Gate Valves Classes 125, 150, 200 and 300

Handwheel—Strong malleable handwheels dissipate heat rapidly and are accurately fitted to stems.

Nameplate—Aluminum nameplates are used for valve identification.

Stem—Copper-silicon bronze stems have excellent corrosion resistance and superior strength.

Bonnet—Bonnets are either threaded, union, or bolted type. Ample packing chamber depth with adequate packing is provided for maximum life.

Wedge—All wedges are the tapered solid type. Wedge guides assure alignment and minimize friction on seats. Wedges are completely out of the line of flow when valves are open.

Body—Bodies have guides for close and accurate disc travel. Threaded pipe ends conform to the ASME B.1.20.1 Standard. Solder ends conform to the ASME Standard for Solder Joint Fittings B16.18. They are suitable for use with Types K, L, and M copper tubing handling nonflammable materials. End flanges of flanged valves are faced and drilled to meet ASME B16.24, the standard covering Classes 150 and 300 bronze flanges.

Seat Rings—Certain valves are furnished with stainless steel seat rings, swaged into bodies. This provides wear resistance and improves corrosion resistance and longer life.

Globe and Angle Valves Classes 125, 150, 200 and 300

Handwheel—Strong malleable handwheels dissipate heat rapidly and are accurately fitted to stems.

Nameplate—Aluminum nameplates are used for valve identification.

Stem—Copper-silicon bronze stems have excellent corrosion resistance and superior strength.

Bonnet—Bonnets are either threaded, union, or bolted type. Ample packing chamber depth with adequate packing is provided for maximum life.

Seat Ring—Renewable seats are furnished on most Class 150, 200, and 300 valves. The materials for each valve in this catalog are clearly specified.

Disc—Discs may be metal in the plug, fullway, needle-type design or PTFE. The available materials are noted on each valve page.

Body—Bodies are designed for easy flow with ample wall sections for adequate strength. Threaded pipe ends conform to the ASME B1.20.1. Solder ends conform to the ASME Standard for Solder Joint Fittings B16.18. They are used with Types K, L and M copper tubing handling nonflammable materials.

End flanges of flanged valves are faced and drilled to meet ASME B16.24, the standard covering Classes 150 and 300 bronze flanges.

Design: Swing and Lift Check Valves Classes 125 - 300

Body—Threaded pipe ends conform to ASME B1.20.1. Most threaded end valves can be bored for silver brazed end connections. Solder ends comply with the ASME Standard for Solder Joint Fittings B16.18 and are suitable for use with Types K, L, and M copper tubing handling nonflammable materials.

End flanges of flanged valves are faced and drilled to meet ASME B16.24.

Cap—Caps on threaded end check valves have threaded or union body connections with sturdy wrench grips.

Disc—Discs may be nonmetallic (PTFE, Viton® or Buna-N) or metal (bronze). The available materials are noted on each valve page. Disc and disc holders are guided during travel by caps or bodies. The nonmetallic discs are securely fastened in disc holders and are easily replaced.

Hinge, Hinge Pin, Side Plug—Swing check hinges are mounted on type 304 hinge pins which are held in place by side plugs.

Marking—For identification, each globe and gate valve has a metal identification plate under the handwheel nut showing the Stockham figure number.

Testing—Before shipment, each and every valve is individually tested under pressure for soundness of body castings and tight closure.

Packaging—All valves are shipped in sturdy cardboard containers. This packaging protects the valves during shipment and facilitates storage.

Weights and Dimensions—Complete information on weights and dimensions is incorporated on the same pages with the valve listings. Weights and dimensions are furnished for estimating purposes only and are subject to change without notice except for basic dimensions established by accepted standards.

Cv COEFFICIENTS*

(For Estimating Purposes Only)

SIZE	GATE	GLOBE		ANGLE	CHECK		
		Std.	Needle		Y-Type Swing	Std. Swing	Lift
1/8	4.66	0.71	0.16	-	-	1.86	-
1/4	8.52	1.31	0.37	1.97	2.41	3.41	0.98
3/8	15.64	2.40	0.51	3.61	4.42	6.25	1.81
1/2	24.89	3.82	1.09	5.75	7.04	9.96	2.87
3/4	45.40	6.96	2.25	10.48	12.84	18.16	5.24
1	76.70	11.77	-	17.71	21.70	30.68	8.86
1 1/4	135.73	20.82	-	31.35	38.40	54.29	15.67
1 1/2	189.09	29.01	-	43.67	53.48	75.64	21.83
2	327.67	50.26	-	75.67	92.67	131.07	37.84
2 1/2	480.32	73.68	-	110.93	-	192.13	55.46
3	741.65	113.76	-	171.28	-	296.66	85.64

* Fully open. Cv = GPM @ 1 PSI Pressure Drop, 60°F Water

Viton® is a registered trademark of DuPont Performance Elastomers L.L.C.

Globe Valve Figure B-13T

Class 125 • Threaded Bonnet • PTFE Disc • Threaded Ends

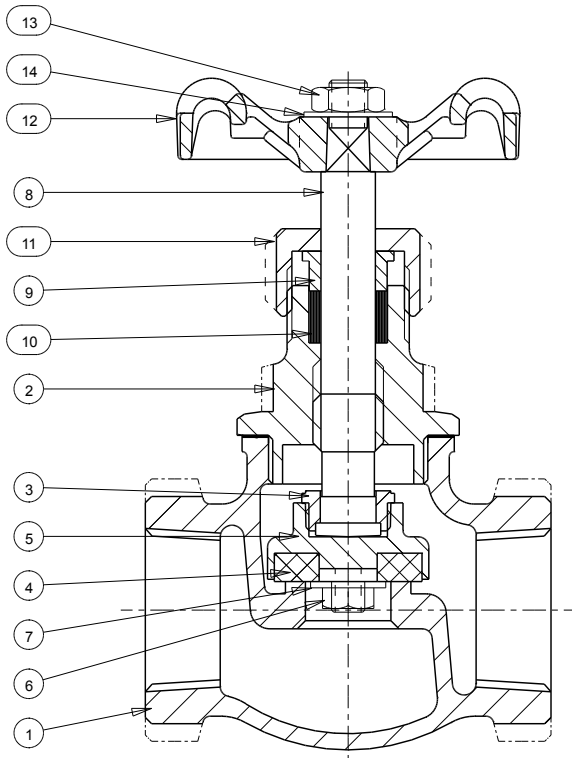

Materials of Construction

No.	Description	Material	ASTM Spec.
1	Body	Bronze	B-62 C83600
2	Bonnet	Bronze	B-62 C83600
3	Disc Stem Ring	Copper Silicon Steel	B-371 C69400
4	Disc	PTFE (25% Glass Filled)	
5	Disc Holder	Bronze	B-62 C83600
6	Disc Retaining Nut	Brass	BSEN12164 CW614N
7	Washer	(2 1/2" - 3") Brass	BSEN12164 CW614N
8	Stem	Copper Silicon Steel	B-371 C69400
9	Gland	Brass	BSEN12164 CW614N
10	Packing	Graphite (Asbestos Free)	
11	Packing Nut	Brass	BSEN12164 CW614N
12	Handwheel	Malleable Iron	A-197 F22000
13	Handwheel Nut	Brass	BSEN12164 CW614N
14	ID Plate	Aluminum	

NOTE:

The addition of the letter "K" at the end of the figure number designates valves assembled & tested in the USA. Materials of Construction & Dimensions are the same.

Industry Standards

With the exception of the port opening, complies with MSS SP-80 Type 2
See Page 7 for Pressure-Temperature Ratings

Dimensions and Weights

Inches (millimeters) - Pounds (kilograms)

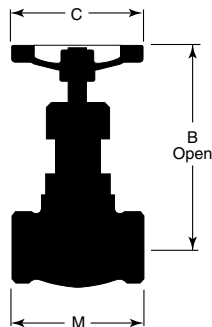

Valve Size	Dimensions			Wt.
	B	C	M	
3/8	3.94	2.05	2.05	0.86
	(100)	(52)	(52)	(0.39)
1/2	3.98	2.05	2.44	1.19
	(101)	(52)	(62)	(0.54)
3/4	4.53	2.05	2.91	1.43
	(115)	(52)	(74)	(0.65)
1	4.92	2.76	3.54	1.79
	(125)	(70)	(90)	(0.81)
1 1/4	5.91	2.76	3.94	3.42
	(150)	(70)	(100)	(1.55)
1 1/2	6.26	3.62	4.53	4.43
	(159)	(92)	(115)	(2.01)
2	7.52	4.06	5.35	6.79
	(191)	(103)	(136)	(3.08)

Globe Valve Figure B-14T

200 CWP • Threaded Bonnet • PTFE Disc • Solder Ends

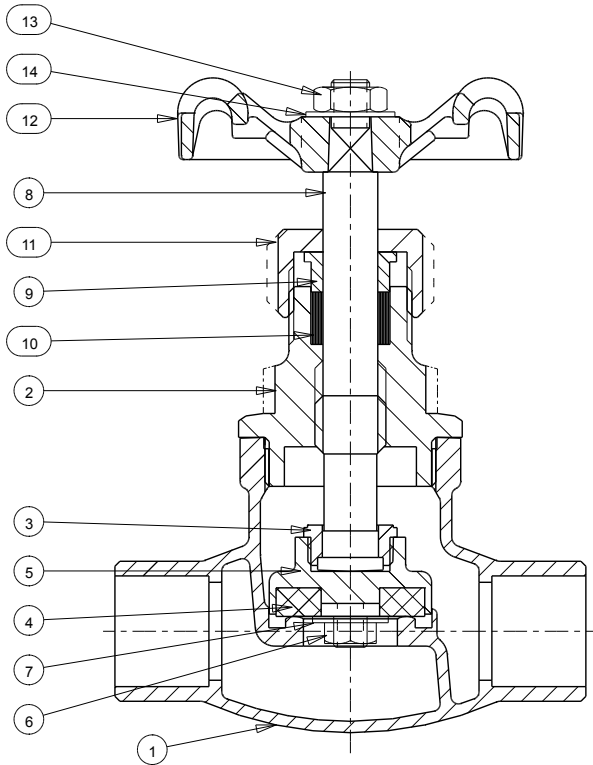

Materials of Construction

No.	Description	Material	ASTM Spec.
1	Body	Bronze	B-62 C83600
2	Bonnet	Bronze	B-62 C83600
3	Disc Stem Ring	Copper Silicon Bronze	B-371 C69400
4	Disc	PTFE (25% Glass Filled)	
5	Disc Holder	Bronze	B-62 C83600
6	Disc Retaining Nut	Brass	BSEN12164 CW614N
7	Washer	Brass	BSEN12164 CW614N
8	Stem	Copper Silicon Steel	B-371 C69400
9	Gland	Brass	BSEN12164 CW614N
10	Packing	Graphite (Asbestos Free)	
11	Packing Nut	Brass	BSEN12164 CW614N
12	Handwheel	Malleable Iron	A-197 F22000
13	Handwheel Nut	Brass	BSEN12164 CW614N
14	ID Plate	Aluminum	

NOTE:

The addition of the letter "K" at the end of the figure number designates valves assembled & tested in the USA. Materials of Construction & Dimensions are the same.

Industry Standards

Complies with MSS SP-80 Type 2

See page 7 for Pressure-Temperature Ratings

Dimensions and Weights

Inches (millimeters) - Pounds (kilograms)

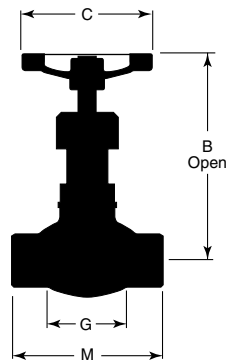

Valve Size	Dimensions				Wt.
	B	C	G	M	
3/8	3.94	2.05	1.56	2.32	1.90
	(100)	(52)	(40)	(59)	(0.39)
1/2	3.98	2.05	1.93	2.91	2.62
	(101)	(52)	(49)	(74)	(0.54)
3/4	4.53	2.05	2.24	3.74	3.15
	(115)	(52)	(57)	(95)	(0.65)
1	4.92	2.76	2.74	4.57	3.95
	(125)	(70)	(70)	(116)	(0.81)
1 1/4	5.91	2.76	2.99	4.92	7.54
	(150)	(70)	(76)	(125)	(1.55)
1 1/2	6.26	3.62	3.52	5.75	9.31
	(159)	(92)	(90)	(146)	(2.01)
2	7.52	4.06	4.40	7.09	14.97
	(191)	(103)	(112)	(180)	(3.08)

Globe Valve Figure B-16

Class 125 • Threaded Bonnet • Bronze Disc • Threaded Ends

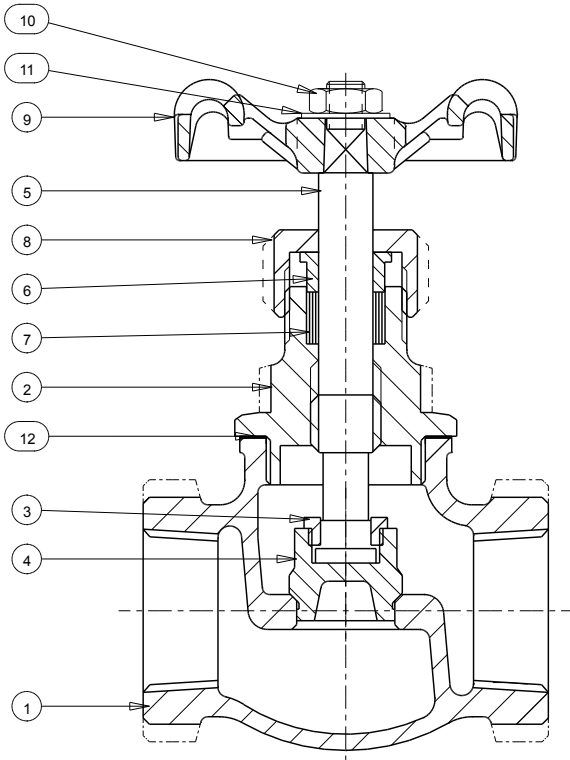

Materials of Construction

No.	Description	Material	ASTM Spec.
1	Body	Bronze	B-62 C83600
2	Bonnet	Brass	B-62 C83600
3	Disc Stem Ring	Copper Silicon Bronze	B-371 C69400
4	Disc	(1/4" - 3/4") Copper Silicon Bronze	B-371 C69400
		(1" - 2") Bronze	B-62 C83600
5	Stem	Copper Silicon Bronze	B-371 C69400
6	Gland	Brass	BSEN12164 CW614N
7	Packing	Graphite (Asbestos Free)	
8	Packing Nut	Brass	BSEN12164 CW614N
9	Handwheel	Malleable Iron	A-197 F22000
10	Handwheel Nut	Brass	BSEN12164 CW614N
11	ID Plate	Aluminum	
12	Gasket	Synthetic Glass Fiber with Nitrile Filled	

NOTE:

The addition of the letter "K" at the end of the figure number designates valves assembled & tested in the USA. Materials of Construction & Dimensions are the same.

Industry Standards

Complies with MSS SP-80 Type 1

See page 7 for Pressure-Temperature Ratings

Dimensions and Weights

Inches (millimeters) - Pounds (kilograms)

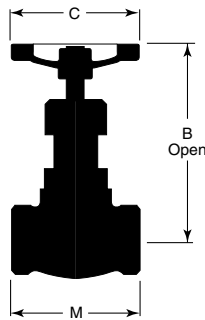

Valve Size	Dimensions			Wt.
	B	C	M	
1/4	3.94	2.05	2.05	0.88
	(100)	(52)	(52)	(0.40)
3/8	3.94	2.05	2.05	0.86
	(100)	(52)	(52)	(0.39)
1/2	3.98	2.05	2.44	1.19
	(101)	(52)	(62)	(0.54)
3/4	4.53	2.05	2.91	1.43
	(115)	(52)	(74)	(0.65)
1	4.92	2.76	3.54	1.98
	(125)	(70)	(90)	(0.90)
1 1/4	5.91	2.76	3.94	3.48
	(150)	(70)	(100)	(1.58)
1 1/2	6.26	3.62	4.53	4.54
	(159)	(92)	(115)	(2.06)
2	7.52	4.06	5.35	7.30
	(191)	(103)	(136)	(3.31)

Globe Valve Figure B-17

200 CWP • Threaded Bonnet • Bronze Disc • Solder Ends

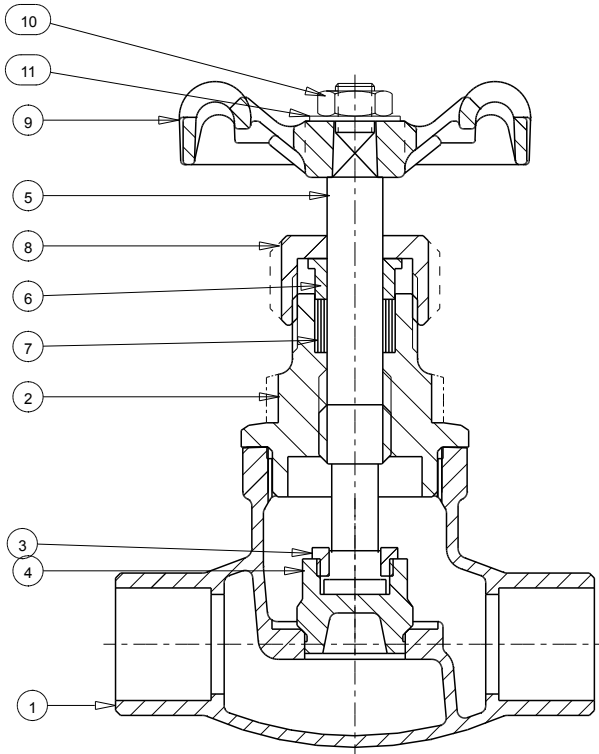

Materials of Construction

No.	Description	Material	ASTM Spec.
1	Body	Bronze	B-62 C83600
2	Bonnet	Bronze	B-62 C83600
3	Disc Stem Ring	Copper Silicon Bronze	B-371 C69400
4	Disc	(1/2" - 3/4") Copper Silicon Bronze	B-371 C69400
		(1" - 2") Bronze	B-62 C83600
5	Stem	Copper Silicon Bronze	B-371 C69400
6	Gland	Brass	BSEN12164 CW614N
7	Packing	Graphite (Asbestos Free)	
8	Packing Nut	Brass	BSEN12164 CW614N
9	Handwheel	Malleable Iron	A-197 F22000
10	Handwheel Nut	Brass	BSEN12164 CW614N
11	ID Plate	Aluminum	

NOTE:

The addition of the letter "K" at the end of the figure number designates valves assembled & tested in the USA. Materials of Construction & Dimensions are the same.

Industry Standards

Complies with MSS SP-80 Type 1

See page 7 for Pressure-Temperature Ratings

Dimensions and Weights

Inches (millimeters) - Pounds (kilograms)

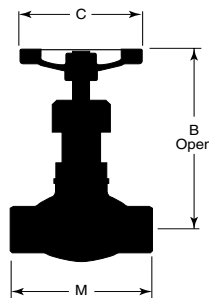

Valve Size	Dimensions			Wt.
	B	C	M	
1/2	3.98	2.05	2.91	1.19
	(101)	(52)	(74)	(0.54)
3/4	4.53	2.05	3.74	1.43
	(115)	(52)	(95)	(0.65)
1	4.92	2.76	4.57	1.98
	(125)	(70)	(116)	(0.90)
1 1/4	5.91	2.76	4.92	3.48
	(150)	(70)	(125)	(1.58)
1 1/2	6.26	3.62	5.75	4.54
	(159)	(92)	(146)	(2.06)
2	7.52	4.06	7.09	7.30
	(191)	(103)	(180)	(3.31)

Angle Valve Figure B-220

Class 150 • Union Bonnet • Brass/Bronze Disc • Thrd. Ends

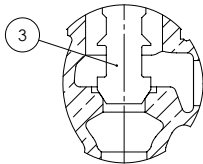
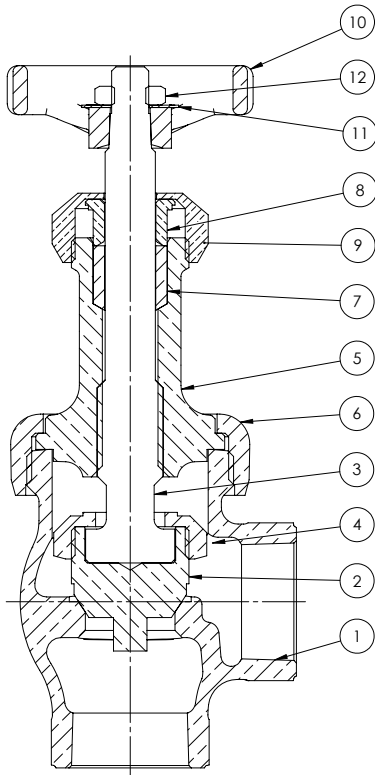

1/4"-1/2"

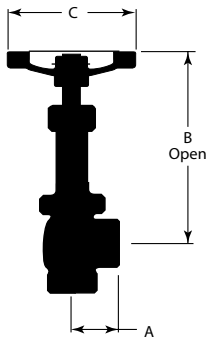

Materials of Construction

No.	Description	Material	ASTM Spec.
1	Body	Bronze	B-62 C83600
2	Disc	(1/2" - 2") Bronze	B-61 C92200
3	Disc Stem	(1/4" - 1 1/2") Bronze	B-371 C69400
4	Disc Stem Ring	(1/2" - 1") Brass	B-16 H02
		(1 1/4" - 2") Bronze	B-61 C92200
5	Bonnet	(1/4" - 3/8") Brass	B-16 H02
		(1/2" - 2") Bronze	B-62 C83600
6	Union Bonnet Ring	Bronze B-62 C83600	
7	Packing	Graphite (Asbestos Free)	
8	Gland	Brass	B-16 H02
9	Packing Nut	(1/4" - 1 1/2") Brass	B-16 H02
		(2") Bronze	B-61 C92200
10	Handwheel	Ductile Iron	
11	ID Plate	Aluminum	
12	Lock Nut	Steel Cadmium	

NOTE:

The addition of the letter "K" at the end of the figure number designates valves assembled & tested in the USA. Materials of Construction & Dimensions are the same.

Industry Standards

Complies with MSS SP-80 Type 1

See page 7 for Pressure-Temperature Ratings

Dimensions and Weights

Inches (millimeters) - Pounds (kilograms)

Valve Size	Dimensions			Wt.
	B	C	A	
1/4	4.22	2.76	1.12	1.01
	(107)	(70)	(28)	(0.46)
3/8	4.22	2.76	1.12	.99
	(107)	(70)	(28)	(0.45)
1/2	3.92	2.76	1.15	1.21
	(100)	(70)	(29)	(0.55)
3/4	4.78	2.76	1.39	1.85
	(122)	(70)	(35)	(0.84)
1	5.39	4.02	1.64	3.08
	(137)	(102)	(42)	(1.40)
1 1/4	6.35	4.02	2.00	4.66
	(161)	(102)	(51)	(2.12)
1 1/2	6.74	4.02	2.18	6.12
	(171)	(102)	(55)	(2.78)
2	7.14	4.76	2.69	10.58
	(181)	(121)	(68)	(4.81)

Globe Valve Figure B-20T

300 CWP • Threaded Bonnet • PTFE Disc • Solder Ends

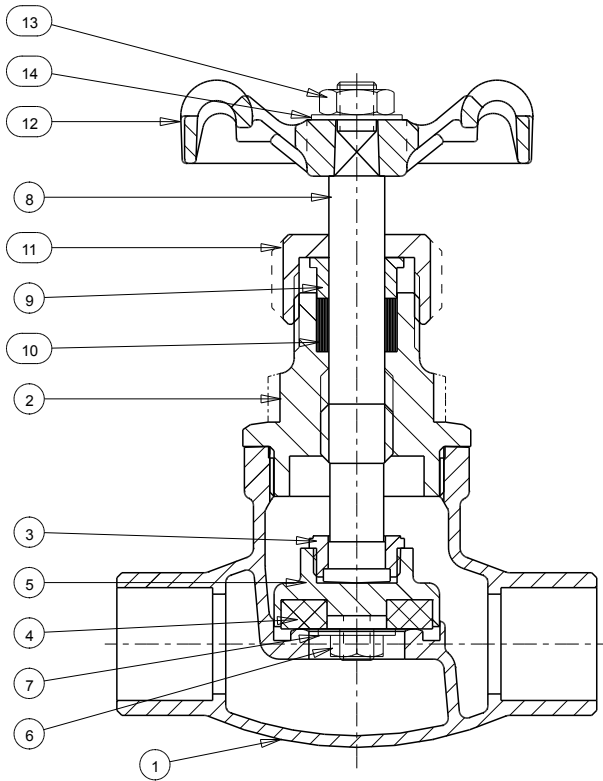

Materials of Construction

No.	Description	Material	ASTM Spec.
1	Body	Bronze	B-62 C83600
2	Bonnet	Bronze	B-62 C83600
3	Disc Stem Ring	Copper Silicon Steel	B-371 C69400
4	Disc	PTFE (25% Glass Filled)	
5	Disc Holder	Bronze	B-62 C83600
6	Disc Retaining Nut	Brass	BSEN12164 CW614N
7	Washer	Brass	BSEN12164 CW614N
8	Stem	Copper Silicon Steel	B-371 C69400
9	Gland	Brass	BSEN12164 CW614N
10	Packing	Graphite (Asbestos Free)	
11	Packing Nut	Brass	BSEN12164 CW614N
12	Handwheel	Malleable Iron	A-197 F22000
13	Handwheel Nut	Brass	BSEN12164 CW614N
14	ID Plate	Aluminum	

NOTE:

The addition of the letter "K" at the end of the figure number designates valves assembled & tested in the USA. Materials of Construction & Dimensions are the same.

Industry Standards

Complies with MSS SP-80 Type 2

See page 7 for Pressure-Temperature Ratings

Dimensions and Weights

Inches (millimeters) - Pounds (kilograms)

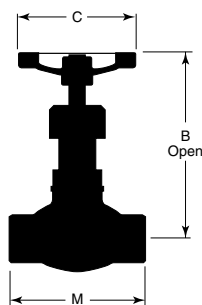

Valve Size	Dimensions			Wt.
	B	C	M	
3/8	3.94	2.05	2.32	1.90
	(100)	(52)	(59)	(0.39)
1/2	3.98	2.05	2.91	2.62
	(101)	(52)	(74)	(0.54)
3/4	4.53	2.05	3.74	3.15
	(115)	(52)	(95)	(0.65)
1	4.92	2.76	4.57	3.95
	(125)	(70)	(116)	(0.81)
1 1/4	5.91	2.76	4.92	7.54
	(150)	(70)	(125)	(1.55)
1 1/2	6.26	3.62	5.75	9.31
	(159)	(92)	(146)	(2.01)
2	7.52	4.06	7.09	14.97
	(191)	(103)	(180)	(3.08)

Globe Valve Figure B-22T

Class 150 • Union Bonnet • PTFE Disc • Threaded Ends

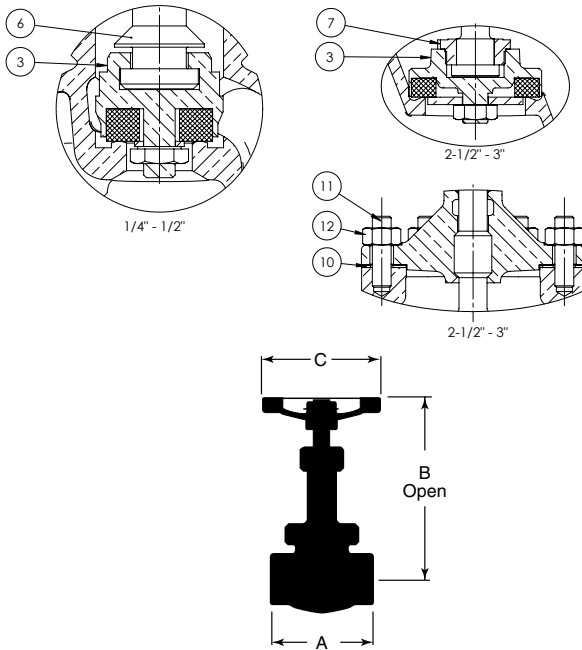
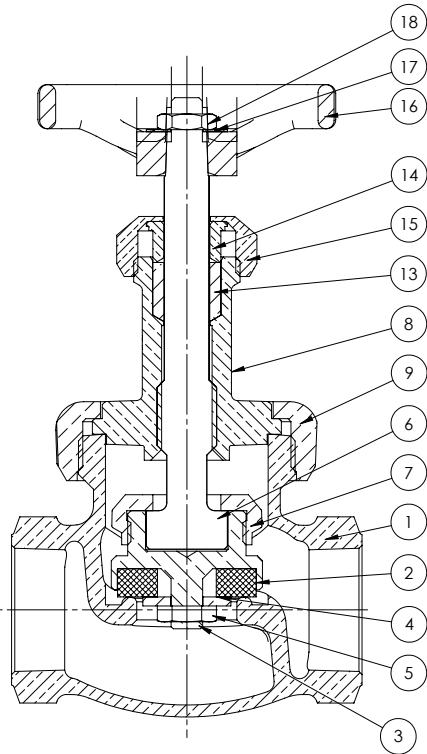

Industry Standards

Complies with MSS SP-80 Type 2

See page 7 for Pressure-Temperature Ratings

Materials of Construction

No.	Description	Material	ASTM Spec.
1	Body	Bronze	B-62 C83600
2	Disc	PTFE (15% Glass Filled)	
3	Disc Holder	(1/4" - 1/2") Brass	B-16 H02
		(3/4" - 3") Bronze	B-62 C83600
4	Disc Washer	Brass	B-16 H02
5	Lock Nut	Brass	B-16 H02
6	Stem	(1/4" - 3/8") Bronze	B-371 C69400
		(1/2" - 3") Bronze	B-371 C69400
7	Disc Stem Ring	(1/2" - 3/4") Brass	B-16 H02
		(2 1/2" - 3") Bronze	B-61 C92200
8	Bonnet	(1/4" - 3/8") Brass	B-16 H02
		(1/2" - 3") Bronze	B-62 C83600
9	Union Bonnet Ring	(1/4" - 2") Bronze	B-62 C83600
10	Gasket	Synthetic Glass Fiber with Nitrile Binder	
11	Stud	Steel Cadmium	A-109 C1145
12	Nut	Mild Steel	A-563 GR. A
13	Packing	Graphite (Asbestos Free)	
14	Gland	Brass	B-16 H02
15	Packing Nut	(1/4" - 1 1/2") Brass	B-16 H02
		(2" - 3") Bronze	B-61 C92200
16	Handwheel	Cast Iron	
17	ID Plate	Aluminum	
18	Lock Nut	Steel Cadmium	

NOTE:

The addition of the letter "K" at the end of the figure number designates valves assembled & tested in the USA. Materials of Construction & Dimensions are the same.

Dimensions and Weights

Inches (millimeters) - Pounds (kilograms)

Valve Size	Dimensions			Wt.
	B	C	A	
1/4	4.19	2.76	1.94	0.97
	(107)	(70)	(49)	(0.44)
3/8	4.20	2.76	1.94	0.99
	(107)	(70)	(49)	(0.45)
1/2	4.06	2.76	2.56	1.25
	(103)	(70)	(65)	(0.57)
3/4	5.00	2.76	2.96	1.91
	(127)	(70)	(75)	(0.87)
1	5.59	4.02	3.50	3.21
	(142)	(102)	(89)	(1.46)
1 1/4	6.51	4.02	4.02	4.47
	(165)	(102)	(102)	(2.03)
1 1/2	6.91	4.02	4.58	6.25
	(176)	(102)	(116)	(2.84)
2	7.40	4.76	5.70	11.07
	(188)	(121)	(145)	(5.03)
*2 1/2	8.69	5.51	7.25	19.65
	(221)	(140)	(184)	(8.93)
*3	10.25	5.98	8.50	33.22
	(260)	(152)	(216)	(15.10)

*2 1/2" and 3" have Bolted Bonnet

Angle Valve Figure B-222T

Class 150 • Union Bonnet • PTFE Disc • Threaded Ends

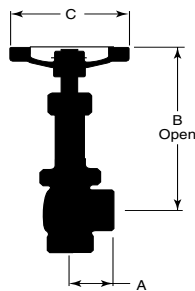
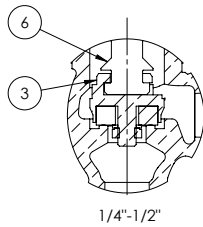
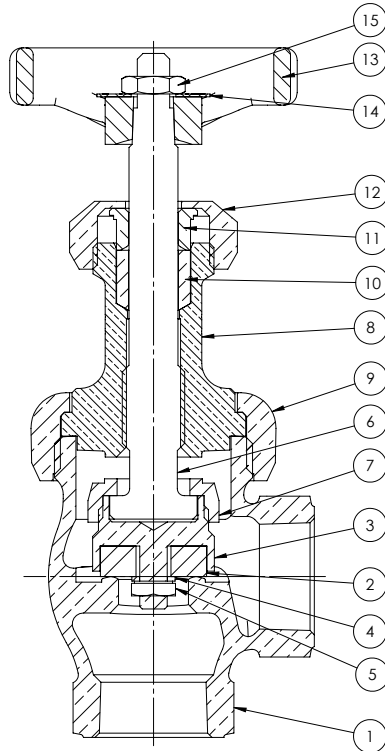

Materials of Construction

No.	Description	Material	ASTM Spec.
1	Body	Bronze	B-62 C83600
2	Disc	PTFE (15% Glass Filled)	
3	Disc Holder	(1/4" - 1/2") Brass (3/4" - 2") Bronze	B-16 H02 B-62 C83600
4	Stem	Bronze	B-371 C69400
5	Lock Nut	Brass	B-16 H02
6	Disc Washer	Brass	B-16 H02
7	Disc Stem Ring	Bronze	B-61 C92200
8	Bonnet	(1/8" - 3/8") Brass (1/2" - 2") Bronze	B-16 H02 B-62 C83600
9	Packing	Graphite (Asbestos Free)	
10	Gland	Brass	B-16 H02
11	Packing Nut	(1/4" - 1 1/2") Brass (2") Bronze	B-16 H02 B-61 C83600
12	Union Bonnet Ring	Bronze	B-62 C83600
13	Handwheel	Cast Iron	
14	ID Plate	Aluminum	
15	Lock Nut	Steel Cadmium	

NOTE:

The addition of the letter "K" at the end of the figure number designates valves assembled & tested in the USA. Materials of Construction & Dimensions are the same.

Industry Standards

Complies with MSS SP-80 Type 2

See page 7 for Pressure-Temperature Ratings

Dimensions and Weights

Inches (millimeters) - Pounds (kilograms)

Valve Size	Dimensions			Wt.
	B	C	A	
1/4	4.05	2.76	1.13	1.03
	(103)	(70)	(29)	(0.47)
3/8	4.05	2.76	1.13	1.01
	(103)	(70)	(29)	(0.46)
1/2	3.92	2.76	1.15	1.21
	(100)	(70)	(29)	(0.55)
3/4	4.78	2.76	1.39	1.80
	(122)	(70)	(35)	(0.82)
1	5.42	4.02	1.64	3.01
	(138)	(102)	(42)	(1.37)
1 1/4	6.38	4.02	2.00	4.51
	(162)	(102)	(51)	(2.05)
1 1/2	6.69	4.02	2.18	6.01
	(170)	(102)	(55)	(2.73)
2	7.14	4.76	2.65	10.69
	(181)	(121)	(67)	(4.86)

Globe Valve Figure B-29

Class 150 • Union Bonnet* • Stainless Steel Disc • Thrd. Ends

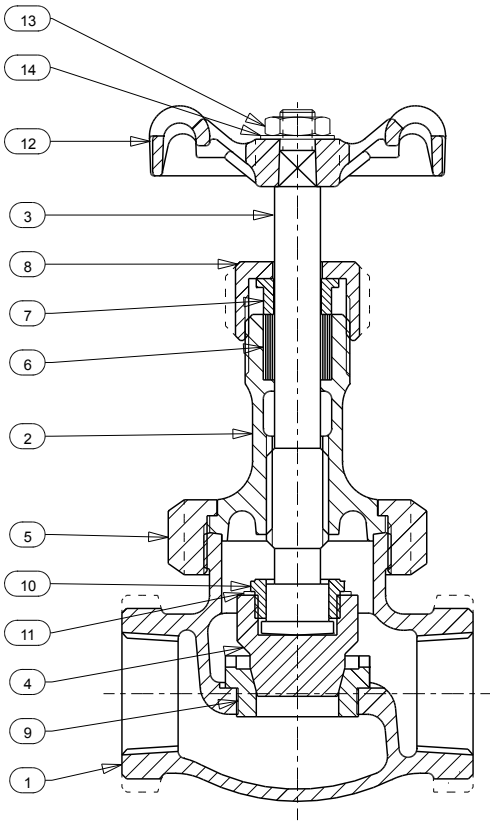

Materials of Construction

No.	Description	Material	ASTM Spec.
1	Body	Bronze	B-61 C92200
2	Bonnet	Bronze	B-61 C92200
3	Stem	Copper Silicon Bronze	B-371 C69400
4	Disc	316 Stainless Steel	
5	Union Ring	Bronze	B-62 C83600
6	Packing	Graphite (Asbestos Free)	
7	Gland	Brass	BSEN12164 CW614N
8	Packing Nut	(1/4" - 1 1/2") Brass	BSEN12164 CW614N
		(2" - 3") Bronze	B-62 C83600
9	Body Seat Ring	13% CR. Steel	BS970P11 410S21 or BS970P11 431S29
10	Disc Stem Ring	Mang. Bronze	B-371 C69400
11	Lock Washer	Brass	BS2870 CZ123
12	Handwheel	Malleable Iron	A197 F22000
13	Handwheel Nut	Brass	BSEN12164 CW614N
14	ID Plate	Aluminum	

NOTE:

The addition of the letter "K" at the end of the figure number designates valves assembled & tested in the USA. Materials of Construction & Dimensions are the same.

Industry Standards

Complies with MSS SP-80 Type 3

See page 7 for Pressure-Temperature Ratings

Dimensions and Weights

Inches (millimeters) - Pounds (kilograms)

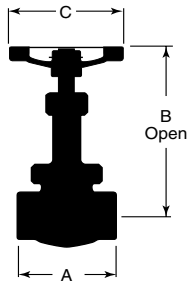

Valve Size	Dimensions			Wt.
	B	C	A	
1/4	4.80	2.05	2.32	1.24
	(122)	(52)	(59)	(0.56)
3/8	4.80	2.05	2.32	1.24
	(122)	(52)	(59)	(0.55)
1/2	5.51	2.56	2.68	1.76
	(140)	(65)	(68)	(0.80)
3/4	5.98	2.76	3.19	2.73
	(152)	(70)	(81)	(1.24)
1	6.73	3.07	3.74	4.01
	(171)	(78)	(95)	(1.82)
1 1/4	7.60	3.62	4.25	6.02
	(193)	(92)	(108)	(2.73)
1 1/2	8.66	4.06	4.76	8.34
	(220)	(103)	(121)	(3.78)
2	9.88	4.76	5.75	13.30
	(251)	(121)	(146)	(6.03)
*2 1/2	10.98	5.98	7.24	24.04
	(279)	(152)	(184)	(10.9)
*3	12.32	7.00	8.87	36.16
	(313)	(178)	(210)	(16.4)

*2 1/2" and 3" have Bolted Bonnet

Globe Valve Figure B-32T

Class 200 • Union Bonnet • PTFE Disc • Threaded Ends

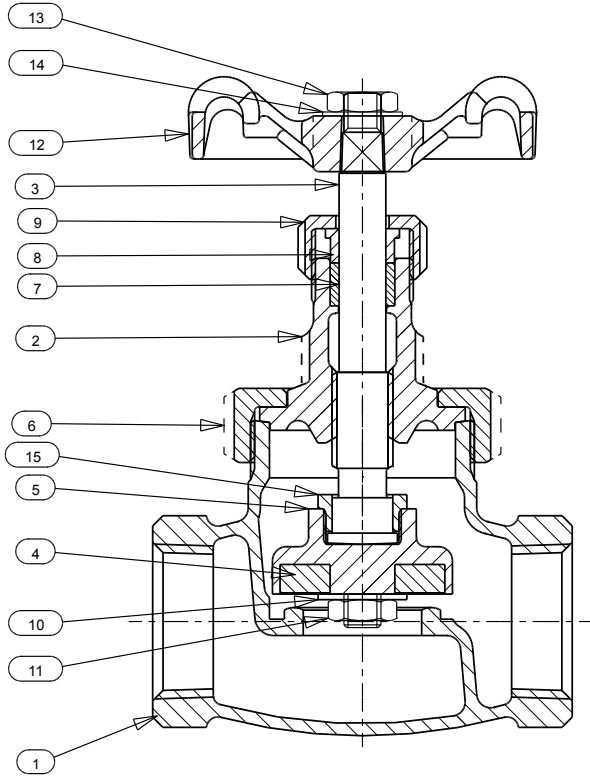

Materials of Construction

No.	Description	Material	ASTM Spec.
1	Body	Bronze	B-61 C92200
2	Bonnet	Bronze	B-61 C92200
3	Stem	Copper Silicon Bronze	B-371 C69400
4	Disc	PTFE (25% Glass Filled)	
5	Disc Holder	Bronze	B-62 C83600
6	Union Ring	Bronze	B-62 C83600
7	Packing	Graphite (Asbestos Free)	
8	Gland	Brass	BSEN12164 CW614N
9	Packing Nut	(1/4" - 1 1/2") Brass	BSEN12164 CW614N
		(2") Bronze	B-62 C83600
10	Washer	Brass	BSEN12164 CW614N
11	Disc Retaining Nut	Brass	BSEN12164 CW614N
12	Handwheel	Malleable Iron	
13	Handwheel Nut	Brass	BSEN12164 CW614N
14	ID Plate	Aluminum	
15	Stem Ring	Copper Silicon Bronze	B-371 C69400

NOTE:

The addition of the letter "K" at the end of the figure number designates valves assembled & tested in the USA. Materials of Construction & Dimensions are the same.

Industry Standards

Complies with MSS SP-80 Type 2

See page 7 for Pressure-Temperature Ratings

Dimensions and Weights

Inches (millimeters) - Pounds (kilograms)

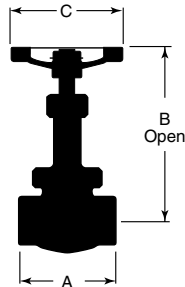

Valve Size	Dimensions			Wt.
	B	C	A	
1/4	3.94	2.05	2.05	1.10
	(100)	(52)	(52)	(0.50)
3/8	3.94	2.05	2.05	1.08
	(100)	(52)	(52)	(0.49)
1/2	3.98	2.05	2.44	1.61
	(101)	(52)	(62)	(0.73)
3/4	4.53	2.05	2.91	2.40
	(115)	(52)	(74)	(1.09)
1	4.92	2.76	3.54	3.84
	(125)	(70)	(90)	(1.74)
1 1/4	5.91	2.76	3.94	5.38
	(150)	(70)	(100)	(2.44)
1 1/2	6.26	3.62	4.53	7.32
	(159)	(92)	(115)	(3.32)
2	7.52	4.06	5.35	12.22
	(191)	(103)	(136)	(5.54)

Globe Valve Figure B-37

Class 200 • Union Bonnet • Brz. Disc • Regrinding Seat • Thrd.

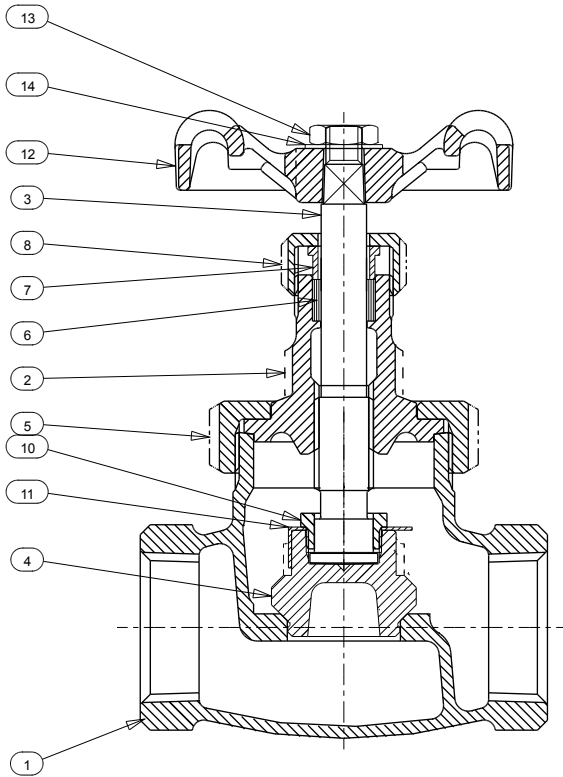

Materials of Construction

No.	Description	Material	ASTM Spec.
1	Body	Bronze	B-61 C92200
2	Bonnet	Bronze	B-61 C92200
3	Stem	Copper Silicon Bronze	B-371 C69400
4	Disc	Bronze	B-61 C92200
5	Union Ring	Bronze	B-62 C83600
6	Packing	Graphite (Asbestos Free)	
7	Gland	Brass	BSEN12164 CW614N
8	Packing Nut	(1/4" - 1 1/4") Brass (1 1/2" - 2") Bronze	BSEN12164 CW614N B-62 C83600
10	Disc Stem Ring	Copper Silicon Bronze	B-371 C69400
11	Lock Washer	Brass	BSEN1652 CW507L
12	Handwheel	Malleable Iron	A-197 F22000
13	Handwheel Nut	Brass	BSEN12164 CW614N
14	ID Plate	Aluminum	

NOTE:

The addition of the letter "K" at the end of the figure number designates valves assembled & tested in the USA. Materials of Construction & Dimensions are the same.

Industry Standards

Complies with MSS SP-80 Type 1

See page 7 for Pressure-Temperature Ratings

Dimensions and Weights

Inches (millimeters) - Pounds (kilograms)

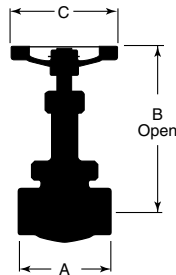

Valve Size	Dimensions			Wt.
	B	C	A	
1/4	4.80	2.05	2.05	1.24
	(122)	(52)	(52)	(0.56)
3/8	4.80	2.05	2.05	1.21
	(122)	(52)	(52)	(0.55)
1/2	5.51	2.56	2.44	1.76
	(140)	(65)	(62)	(0.80)
3/4	5.98	2.76	2.91	2.73
	(152)	(70)	(74)	(1.24)
1	6.73	3.07	3.54	4.01
	(171)	(78)	(90)	(1.82)
1 1/4	7.60	3.62	3.94	6.02
	(193)	(92)	(100)	(2.73)
1 1/2	8.66	4.06	4.53	8.34
	(220)	(103)	(115)	(3.78)
2	9.88	4.76	5.35	13.30
	(251)	(121)	(136)	(6.03)

Globe Valve Figure B-62

Class 200 • Union Bonnet* • SS Plug Type Disc • Thrd. Ends

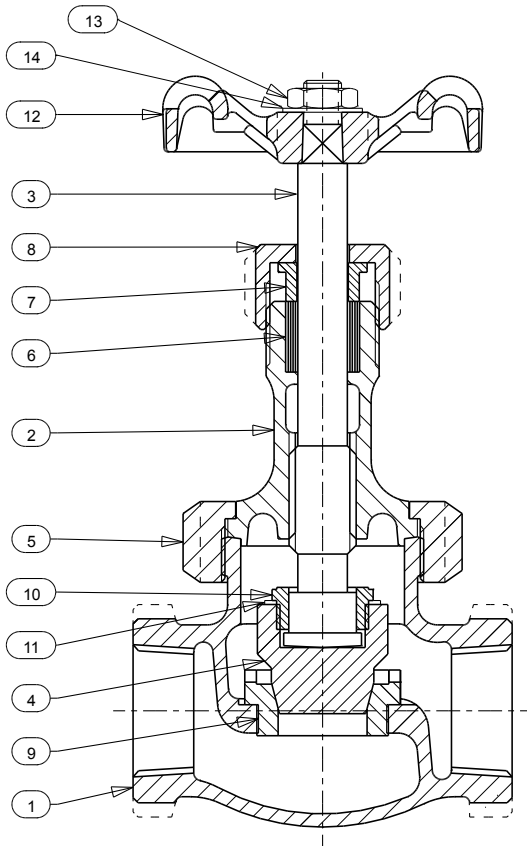

Materials of Construction

No.	Description	Material	ASTM Spec.
1	Body	Bronze	B-61 C92200
2	Bonnet	Bronze	B-61 C92200
3	Stem	Copper Silicon Bronze	B-371 C69400
4	Disc	316 Stainless Steel	
5	Union Ring	Bronze	B-62 C83600
6	Packing	Graphite (Asbestos Free)	
7	Gland	Brass	BSEN12164 CW614N
8	Packing Nut	(1/4" - 1 1/2") Brass	BSEN12164 CW614N
		(2" - 3") Bronze	B-62 C83600
9	Body Seat Ring	13% CR Steel	BS970 Pt1 410S21 or BS970 Pt1 431S29
10	Disc Stem Ring	Mang. Bronze	B-371 C69400
11	Lock Washer	Brass	BS2870 - CZ 123
12	Handwheel	Malleable Iron	A-197 F22000
13	Handwheel Nut	Brass	BSEN12164 CW614N
14	ID Plate	Aluminum	

NOTE:

The addition of the letter "K" at the end of the figure number designates valves assembled & tested in the USA. Materials of Construction & Dimensions are the same.

Industry Standards

Complies with MSS SP-80 Type 3

See page 7 for Pressure-Temperature Ratings

Dimensions and Weights

Inches (millimeters) - Pounds (kilograms)

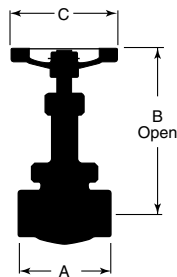

Valve Size	Dimensions			Wt.
	B	C	A	
1/4	4.80	2.05	2.32	1.24
	(122)	(52)	(59)	(0.56)
3/8	4.80	2.05	2.32	1.24
	(122)	(52)	(59)	(0.56)
1/2	5.51	2.56	2.68	1.76
	(140)	(65)	(68)	(0.80)
3/4	5.98	2.76	3.19	2.73
	(152)	(70)	(81)	(1.24)
1	6.73	3.07	3.74	4.01
	(171)	(78)	(95)	(1.82)
1 1/4	7.60	3.62	4.25	6.02
	(193)	(92)	(108)	(2.73)
1 1/2	8.66	4.06	4.76	8.34
	(220)	(103)	(121)	(3.78)
2	9.88	4.76	5.75	13.30
	(251)	(121)	(146)	(6.03)
*2 1/2	10.98	5.98	7.24	24.04
	(279)	(152)	(184)	(10.9)
*3	12.32	7.00	8.27	36.16
	(313)	(178)	(210)	(16.4)

*2 1/2" and 3" have Bolted Bonnet

Globe Valve Figure B-64

Class 200 • Threaded Bonnet • Needle Type Disc • Thrd. Ends

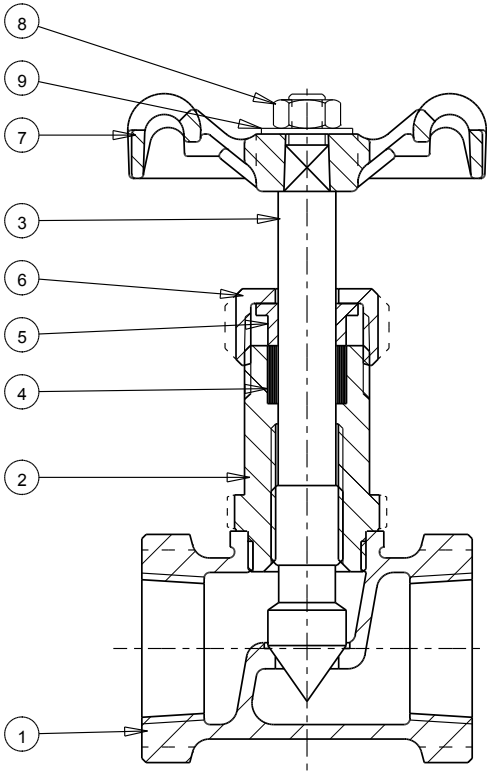

Materials of Construction

No.	Description	Material	ASTM Spec.
1	Body	Bronze	B-62 C83600
2	Bonnet	(1/8" - 1/2") Sil. Al. Bronze	BSEN12163 CW301G
		(3/4") Brass	BSEN12164 CW614N
3	Stem	Sil. Al. Bronze	BSEN12163 CW301G
4	Packing	Graphite (Asbestos Free)	
5	Gland	Brass	BSEN12164 CW614N
6	Packing Nut	Brass	BSEN12164 CW614N
7	Handwheel	Aluminum	
8	Handwheel Nut	Brass	BSEN12164 CW614N
9	ID Plate	Aluminum	

NOTES:

The addition of the letter "K" at the end of the figure number designates valves assembled & tested in the USA. Materials of Construction & Dimensions are the same.

See page 7 for Pressure-Temperature Ratings.

Dimensions and Weights

Inches (millimeters) - Pounds (kilograms)

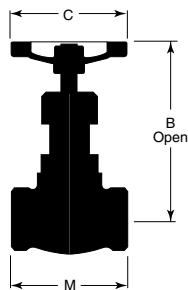

Valve Size	Dimensions			Wt.
	B	C	M	
1/8	2.91	1.73	1.14	0.29
	(74)	(44)	(29)	(0.13)
1/4	2.87	1.73	1.54	0.33
	(73)	(44)	(39)	(0.15)
3/8	3.03	1.73	1.77	0.46
	(77)	(44)	(45)	(0.21)
1/2	3.58	2.05	2.01	0.64
	(91)	(52)	(51)	(0.29)
3/4	4.09	2.56	2.28	1.01
	(104)	(65)	(58)	(0.46)

Angle Valve Figure B-264

Class 200 • Threaded Bonnet • Needle Type Disc • Thrd. Ends

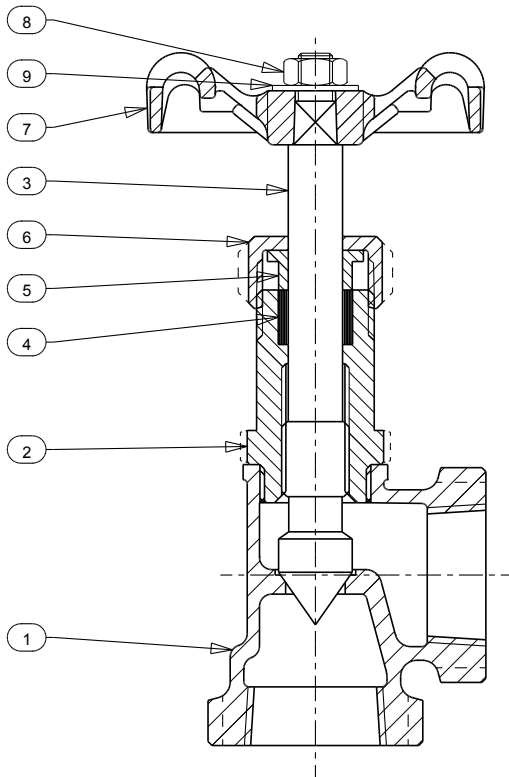

Materials of Construction

No.	Description	Material	ASTM Spec.
1	Body	Bronze	B-62 C83600
2	Bonnet	($\frac{1}{8}$ " - $\frac{3}{8}$ ") Sil. Al. Bronze	BSEN12163 CW301G
		($\frac{1}{2}$ " - $\frac{3}{4}$ ") Brass	BSEN12164 CW614N
3	Stem	Sil. Al. Bronze	BSEN12163 CW301G
4	Packing	Graphite (Asbestos Free)	
5	Gland	Brass	BSEN12164 CW614N
6	Packing Nut	Brass	BSEN12164 CW614N
7	Handwheel	Aluminum	
8	Handwheel Nut	Brass	BSEN12164 CW614N
9	ID Plate	Aluminum	

NOTES:

The addition of the letter "K" at the end of the figure number designates valves assembled & tested in the USA. Materials of Construction & Dimensions are the same.

See page 7 for Pressure-Temperature Ratings.

Dimensions and Weights

Inches (millimeters) - Pounds (kilograms)

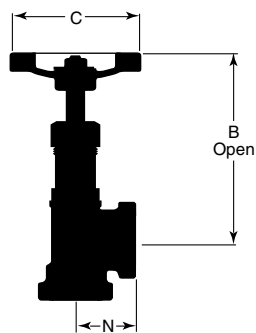

Valve Size	Dimensions			Wt.
	B	C	N	
$\frac{1}{8}$	2.91	1.73	0.59	0.29
	(74)	(44)	(15)	(0.13)
$\frac{1}{4}$	2.87	1.73	0.79	0.33
	(73)	(44)	(20)	(0.15)
$\frac{3}{8}$	3.03	1.73	0.91	0.46
	(77)	(44)	(23)	(0.21)
$\frac{1}{2}$	3.58	2.05	1.06	0.64
	(91)	(52)	(27)	(0.29)
$\frac{3}{4}$	4.09	2.56	1.26	1.01
	(104)	(65)	(32)	(0.46)

Globe Valve Figure B-66

Class 300 • Union Bonnet* • Brz. Disc • Regrinding Seat • Thrd.

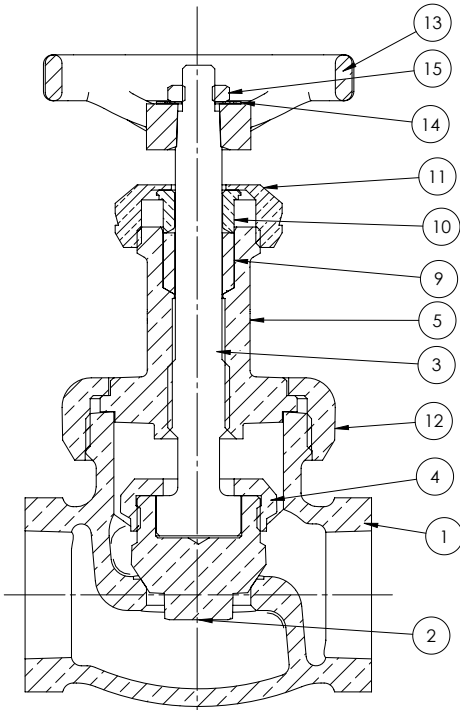

Materials of Construction

No.	Description	Material	ASTM Spec.
1	Body	Bronze	B-61 C92200
2	Disc	(1/2" - 3") Bronze	B-61 C92200
3	Disc Stem	(1/4" - 3/8") Bronze	B-371 C69400
		(1/2" - 3") Bronze	B-371 C69400
4	Disc Stem Ring	(1/2" - 3") Bronze	B-61 C92200
5	Bonnet	Bronze	B-61 C92200
6	Gasket	Synthetic/Glass Fiber with Nitrile Binder	
7	Stud	Steel Cadmium	A-109 C1144
8	Stud Nut	Mild Steel	A-563 Gr. A
9	Packing	Graphite (Asbestos Free)	
10	Gland	Brass	B-16 H02
11	Packing Nut	Bronze	B-61 C92200
12	Union Bonnet Ring	Bronze	B-61 C92200
13	Handwheel	Ductile Iron	
14	ID Plate	Aluminum	
15	Lock Nut	Steel Cadmium	

NOTE:

The addition of the letter "K" at the end of the figure number designates valves assembled & tested in the USA. Materials of Construction & Dimensions are the same.

Industry Standards

Complies with MSS SP-80 Type 1

See page 7 for Pressure-Temperature Ratings

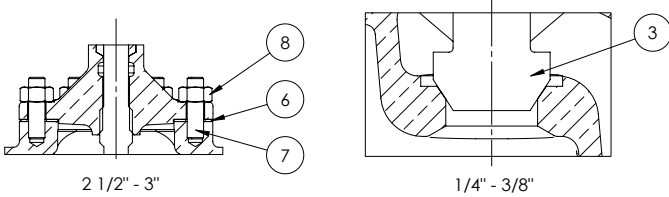

Dimensions and Weights

Inches (millimeters) - Pounds (kilograms)

Valve Size	Dimensions			Wt.
	B	C	A	
1/4	4.37	2.76	1.94	0.97
	(111)	(70)	(49)	(0.44)
3/8	4.37	2.76	1.94	0.95
	(111)	(70)	(49)	(0.43)
1/2	4.04	2.76	2.56	1.34
	(103)	(70)	(65)	(0.61)
3/4	4.96	2.76	2.96	2.20
	(126)	(70)	(75)	(1.00)
1	5.56	4.02	3.32	3.48
	(141)	(102)	(84)	(1.58)
1 1/4	6.48	4.02	4.02	4.93
	(165)	(102)	(102)	(2.24)
1 1/2	6.88	4.02	4.58	6.75
	(175)	(102)	(116)	(3.07)
2	7.39	4.76	5.70	12.47
	(188)	(121)	(145)	(5.67)
*2 1/2	9.31	5.98	7.25	20.39
	(237)	(152)	(184)	(9.27)
*3	10.57	5.98	8.50	34.72
	(269)	(152)	(216)	(15.78)

* 2 1/2" and 3" have Bolted Bonnet

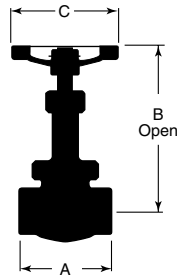

Angle Valve Figure B-266

Class 300 • Union Bonnet • Brnz. Disc • Regrinding Seat • Thrd.

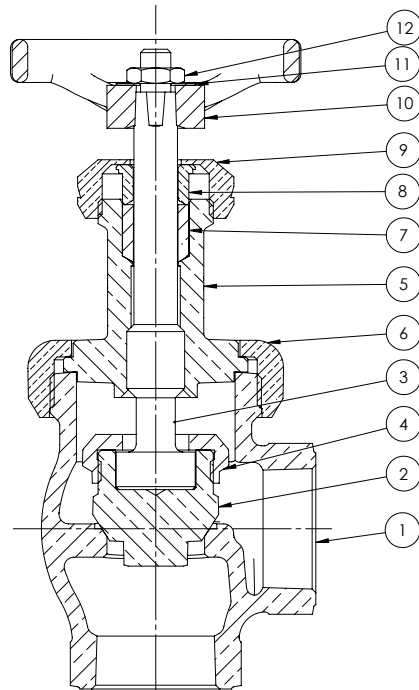

Materials of Construction

No.	Description	Material	ASTM Spec.
1	Body	Bronze	B-61 C92200
2	Disc	(1/2" - 2") Bronze	B-61 C92200
3	Disc Stem	Bronze	B-371 C69400
4	Disc Stem Ring	(1/2" - 3/4") Brass	B-16 H02
		(1" - 2") Bronze	B-61 C92200
5	Bonnet	(1/4" - 3/8") Brass	B-16 H02
		(1/2" - 2") Bronze	B-61 C92200
6	Union Bonnet Ring	Bronze	B-61 C92200
7	Packing	Graphite (Asbestos Free)	
8	Gland	Brass	B-16 H02
9	Packing Nut	(1/4" - 1 1/2") Brass	B-16 H02
		(2") Bronze	B-61 C92200
10	Handwheel	Ductile Iron	
11	ID Plate	Aluminum	
12	Lock Nut	Steel Cadmium	

NOTE:

The addition of the letter "K" at the end of the figure number designates valves assembled & tested in the USA. Materials of Construction & Dimensions are the same.

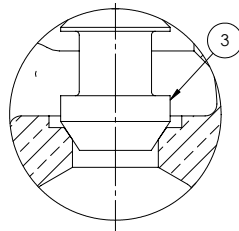

1/4" TO 3/8"

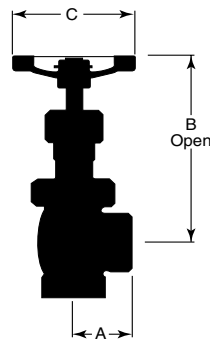

Industry Standards

Complies with MSS SP-80 Type 1

See page 7 for Pressure-Temperature Ratings

Dimensions and Weights

Inches (millimeters) - Pounds (kilograms)

Valve Size	Dimensions			Wt.
	B	C	A	
1/4	4.22	2.75	1.12	0.99
	(107)	(70)	(29)	(0.45)
3/8	4.22	2.75	1.12	0.97
	(107)	(70)	(28)	(0.44)
1/2	3.92	2.75	1.15	1.30
	(100)	(70)	(29)	(0.59)
3/4	4.78	2.75	1.39	2.13
	(122)	(70)	(35)	(0.97)
1	5.39	4.00	1.64	3.43
	(137)	(102)	(42)	(1.56)
1 1/4	6.36	4.00	2.00	5.21
	(162)	(102)	(51)	(2.37)
1 1/2	6.74	4.00	2.18	6.58
	(171)	(102)	(55)	(2.99)
2	7.14	4.75	2.69	12.06
	(181)	(121)	(68)	(5.48)

Globe Valve Figure B-74

Class 300 • Union Bonnet* • Plug-Type Disc • Renewable SS Seats

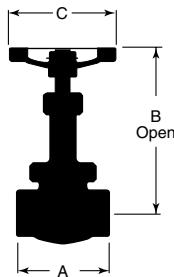
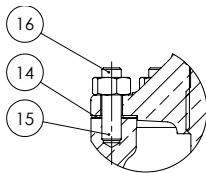
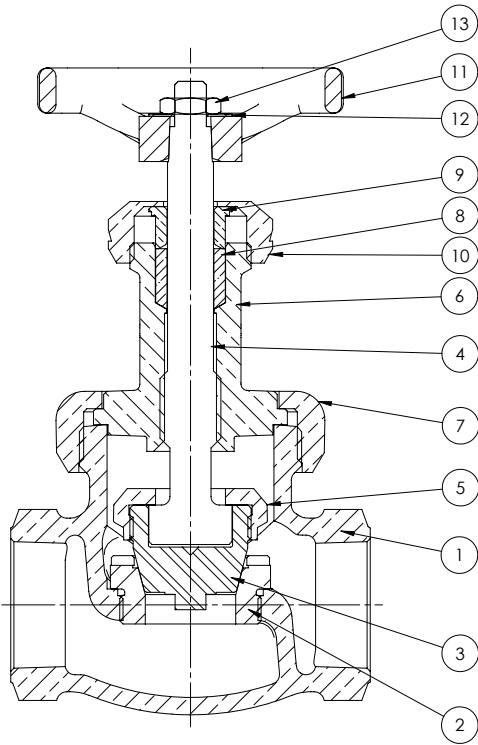

Industry Standards

Complies with MSS SP-80 Type 3

See page 7 for Pressure-Temperature Ratings

Materials of Construction

No.	Description	Material	ASTM Spec.
1	Body	Bronze	B-61 C92200
2	Body Seat Ring	Stainless Steel	AISI 420 SS
3	Disc	Stainless Steel	AISI 420F SS
4	Stem	Bronze	B-371 C69400
5	Disc Stem Ring	(1/4" - 3/4") Brass	B-16 H02
		(1" - 3") Bronze	B-61 C92200
6	Bonnet	(1/4" - 3/8") Brass	B-16 H02
		(1/2" - 3") Bronze	B-61 C92200
7	Union Bonnet Ring	Bronze	B-61 C92200
8	Packing	Graphite (Asbestos Free)	
9	Gland	Brass	B-16 H02
10	Packing Nut	(1/4" - 1 1/2") Brass	B-16 H02
		(2" - 3") Bronze	B-61 C92200
11	Handwheel	Ductile Iron	
12	ID Plate	Aluminum	
13	Lock Nut	Steel Cadmium	
14	Gasket	Synthetic/Glass Fiber with Nitrile Binder	
15	Stud	Steel Cadmium	
16	Nut	Mild Steel	

NOTE:

The addition of the letter "K" at the end of the figure number designates valves assembled & tested in the USA. Materials of Construction & Dimensions are the same.

Dimensions and Weights

Inches (millimeters) - Pounds (kilograms)

Valve Size	Dimensions			Wt.
	B	C	A	
1/4	4.47	2.76	1.94	0.97
	(114)	(70)	(49)	(0.44)
3/8	4.47	2.76	1.94	0.95
	(114)	(70)	(49)	(0.43)
1/2	4.06	2.76	2.56	1.36
	(103)	(70)	(65)	(0.62)
3/4	4.98	2.76	2.96	2.20
	(127)	(70)	(75)	(1.00)
1	5.59	4.02	3.50	3.50
	(142)	(102)	(89)	(1.59)
1 1/4	6.48	4.02	4.02	4.93
	(165)	(102)	(102)	(2.24)
1 1/2	6.85	4.02	4.58	6.86
	(174)	(102)	(116)	(3.12)
2	7.39	4.76	5.70	12.83
	(188)	(121)	(145)	(5.83)
*2 1/2	9.68	5.51	7.24	23.58
	(246)	(140)	(184)	(10.7)
*3	11.02	5.98	8.50	34.83
	(280)	(152)	(216)	(15.8)

* 2 1/2" and 3" have Bolted Bonnet

Angle Valve Figure B-274

Class 300 • Union Bonnet • Plug-Type Disc • Renewable SS Seats

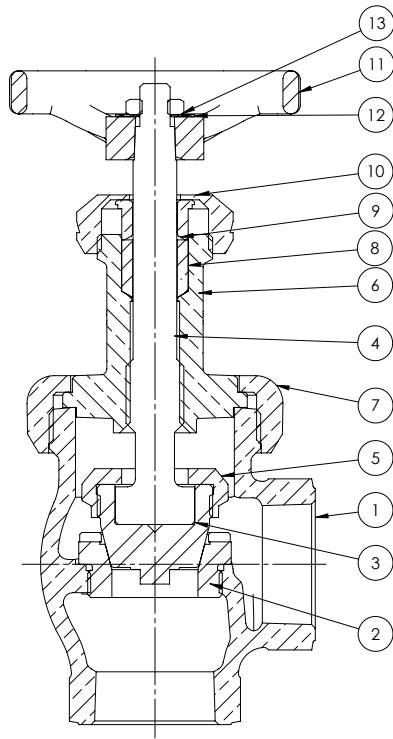

Materials of Construction

No.	Description	Material	ASTM Spec.
1	Body	Bronze	B-61 C92200
2	Body Seat Ring	Stainless Steel	AISI 420 SS
3	Disc	Stainless Steel	AISI 420F SS
4	Stem	Bronze	B-371 C69400
5	Disc Stem Ring	(1/2" - 3/4") Brass	B-16 H02
		(1" - 2") Bronze	B-61 C92200
6	Bonnet	Bronze	B-61 C92200
7	Union Bonnet Ring	Bronze	B-61 C92200
8	Packing	Graphite (Asbestos Free)	
9	Gland	Brass	B-16 H02
10	Packing Nut	(1/2" - 1 1/2") Brass	B-16 H02
		(2") Bronze	B-61 C92200
11	Handwheel	Ductile Iron	
12	ID Plate	Aluminum	
13	Lock Nut	Steel Cadmium	

NOTE:

The addition of the letter "K" at the end of the figure number designates valves assembled & tested in the USA. Materials of Construction & Dimensions are the same.

Industry Standards

Complies with MSS SP-80 Type 3

See page 7 for Pressure-Temperature Ratings

Dimensions and Weights

Inches (millimeters) - Pounds (kilograms)

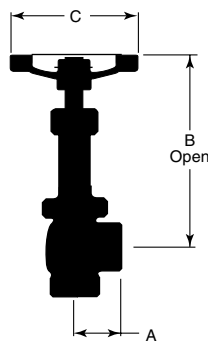

Valve Size	Dimensions			Wt.
	B	C	A	
1/2	3.97	2.76	1.15	1.32
	(101)	(70)	(29)	(0.60)
3/4	4.83	2.76	1.39	2.16
	(123)	(70)	(35)	(0.98)
1	5.41	4.02	1.64	3.45
	(138)	(102)	(42)	(1.57)
1 1/4	6.38	4.02	2.00	5.21
	(162)	(102)	(51)	(2.37)
1 1/2	6.74	4.02	2.18	6.62
	(171)	(102)	(55)	(3.01)
2	7.13	4.76	2.69	12.32
	(181)	(121)	(68)	(5.60)

Gate Valve Figure B-100

Class 125 • Threaded Bonnet • Rising Stem • Threaded Ends

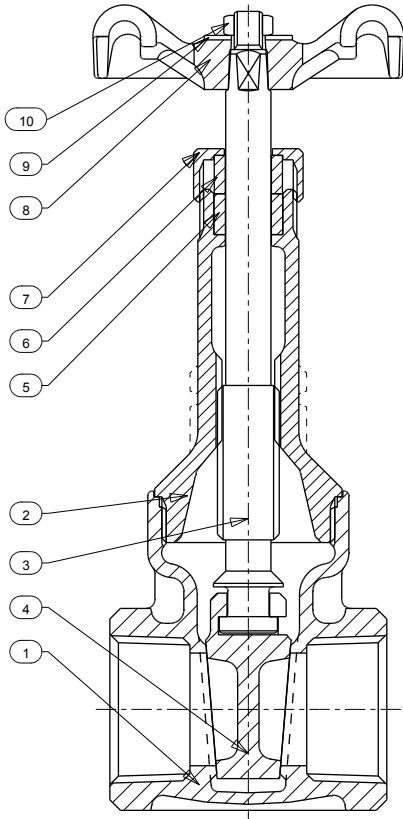

Materials of Construction

No.	Description	Material	ASTM Spec.
1	Body	Bronze	B-62 C83600
2	Bonnet	Bronze	B-62 C83600
3	Stem	Copper Silicon Bronze	B-371 69400
4	Disc	Bronze	B-62 C83600
5	Packing Ring	Graphite (Asbestos Free)	
6	Gland	Brass	BSEN12164 CW614N
7	Packing Nut	Brass	BSEN12164 CW614N
8	Handwheel	Malleable Iron	A-197 F22000
9	ID Plate	Aluminum	
10	Handwheel Nut	Brass	BSEN12164 CW614N

NOTE:

The addition of the letter "K" at the end of the figure number designates valves assembled & tested in the USA. Materials of Construction & Dimensions are the same.

Industry Standards

Complies with MSS SP-80 Type 2

See page 7 for Pressure-Temperature Ratings

Dimensions and Weights

Inches (millimeters) - Pounds (kilograms)

Valve Size	Dimensions			Wt.
	B	C	M	
1/4	4.96	1.75	1.81	0.7
	(126)	(45)	(46)	(0.32)
3/8	4.96	1.75	1.81	0.7
	(126)	(45)	(46)	(0.31)
1/2	5.07	2.06	1.98	1.0
	(129)	(52)	(51)	(0.46)
3/4	6.25	2.56	2.14	1.6
	(159)	(65)	(55)	(0.72)
1	7.44	2.75	2.46	2.4
	(189)	(70)	(63)	(1.10)
1 1/4	8.62	3.06	2.77	3.3
	(219)	(78)	(71)	(1.50)
1 1/2	9.68	3.62	2.85	4.9
	(246)	(92)	(73)	(2.25)
2	11.85	3.62	3.25	7.0
	(301)	(92)	(83)	(3.20)
2 1/2	14.53	5.28	4.25	12.8
	(369)	(134)	(108)	(5.80)
3	16.39	5.28	4.59	18.8
	(416)	(134)	(117)	(8.52)

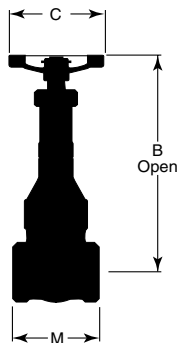

Gate Valve Figure B-108

200 CWP • Threaded Bonnet • Rising Stem • Solder Ends

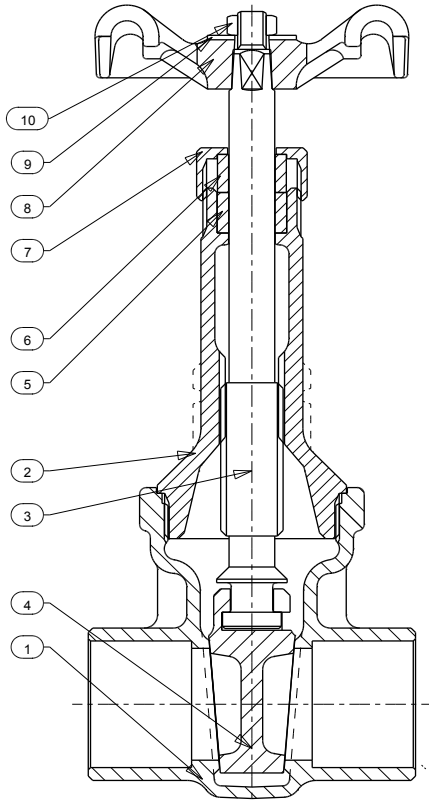

Materials of Construction

No.	Description	Material	ASTM Spec.
1	Body	Bronze	B-62 C83600
2	Bonnet	Bronze	B-62 C83600
3	Stem	Copper Silicon Bronze	B-371 69400
4	Disc	Bronze	B-62 C83600
5	Packing Ring	Graphite (Asbestos Free)	
6	Gland	Brass	BSEN12164 CW614N
7	Packing Nut	Brass	BSEN12164 CW614N
8	Handwheel	Malleable Iron	A-197 F22000
9	ID Plate	Aluminum	
10	Handwheel Nut	Brass	BSEN12164 CW614N

NOTE:

The addition of the letter "K" at the end of the figure number designates valves assembled & tested in the USA. Materials of Construction & Dimensions are the same.

Industry Standards

Complies with MSS SP-80 Type 2

See page 7 for Pressure-Temperature Ratings

Dimensions and Weights

Inches (millimeters) - Pounds (kilograms)

Valve Size	Dimensions				Wt.
	B	C	G*	M	
½	5.07	2.06	0.81	2.00	1.0
	(129)	(52)	(21)	(48)	(0.46)
¾	6.25	2.56	0.86	2.20	1.6
	(159)	(65)	(23)	(61)	(0.72)
1	7.44	2.75	1.04	2.50	2.4
	(189)	(70)	(27)	(73)	(1.10)
1 ¼	8.62	3.06	1.18	2.80	3.3
	(219)	(78)	(30)	(79)	(1.50)
1 ½	9.68	3.62	1.22	2.90	4.9
	(246)	(92)	(31)	(88)	(2.25)
2	11.85	3.62	1.42	3.30	7.0
	(301)	(92)	(36)	(105)	(3.20)
2 ½	14.53	5.28	1.63	4.30	12.8
	(369)	(134)	(42)	(112)	(5.80)
3	16.39	5.28	1.69	4.60	18.8
	(416)	(134)	(43)	(126)	(8.52)

*Piping Make-Up Dimensions

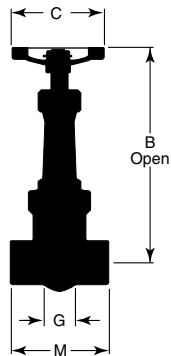

Gate Valve Figure B-103

Class 125 • Threaded Bonnet • Non-Rising Stem • Threaded Ends

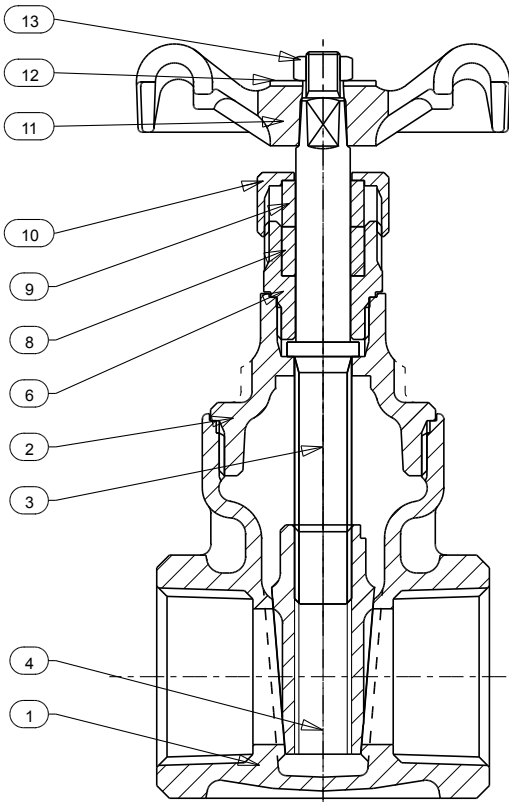

Materials of Construction

No.	Description	Material	ASTM Spec.
1	Body	Bronze	B-62 C83600
2	Bonnet	Bronze	B-62 C83600
3	Stem	Brass	B-371 69400
4	Disc	Bronze	B-62 C83600
6	Stuffing Box	Brass	B-371 69400
8	Packing Ring	Graphite (Asbestos Free)	
9	Gland	Brass	BSEN12164 CW614N
10	Packing Nut	Brass	BSEN12164 CW614N
11	Handwheel	Malleable Iron	A-197 F22000
12	ID Plate	Aluminum	
13	Handwheel Nut	Brass	BSEN12164 CW614N

NOTE:

The addition of the letter "K" at the end of the figure number designates valves assembled & tested in the USA. Materials of Construction & Dimensions are the same.

Industry Standards

Complies with MSS SP-80 Type 1

See page 7 for Pressure-Temperature Ratings

Dimensions and Weights

Inches (millimeters) - Pounds (kilograms)

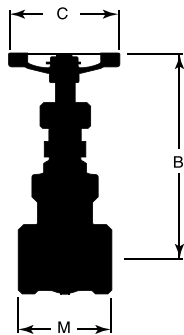

Valve Size	Dimensions			Wt.
	B	C	M	
1/4	2.95	1.75	1.81	0.6
	(75)	(45)	(46)	(0.27)
3/8	2.95	1.75	1.81	0.6
	(75)	(45)	(46)	(0.26)
1/2	3.23	2.06	1.98	0.8
	(82)	(52)	(51)	(0.35)
3/4	3.74	2.56	2.14	1.2
	(95)	(65)	(55)	(0.55)
1	4.64	2.75	2.46	1.8
	(118)	(70)	(63)	(0.84)
1 1/4	5.67	3.06	2.77	2.6
	(144)	(79)	(71)	(1.18)
1 1/2	6.53	3.62	2.85	3.6
	(166)	(92)	(73)	(1.66)
2	7.48	4.06	3.25	5.6
	(190)	(103)	(83)	(2.55)
2 1/2	9.26	5.28	4.25	12.4
	(235)	(134)	(108)	(5.62)
3	9.89	5.28	4.59	17.4
	(251)	(134)	(117)	(7.89)

Gate Valve Figure B-104

200 CWP • Threaded Bonnet • Non-Rising Stem • Solder Ends

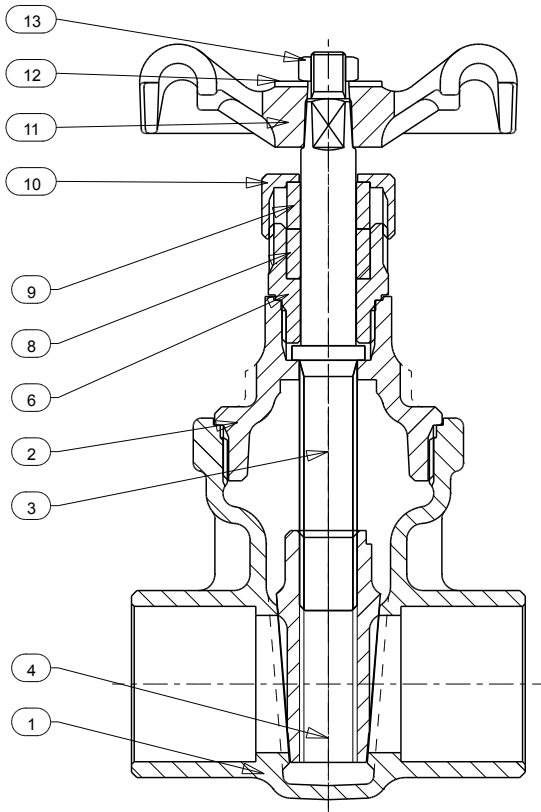

Materials of Construction

No.	Description	Material	ASTM Spec.
1	Body	Bronze	B-62 C83600
2	Bonnet	Bronze	B-62 C83600
3	Stem	Copper Silicon Bronze	B-371 C69400
4	Disc	Bronze	B-62 C83600
6	Stuffing Box	Copper Silicon Brass	B-124 C37700
8	Packing Ring	Graphite (Asbestos Free)	
9	Gland	Brass	BSEN12164 CW614N
10	Packing Nut	Brass	BSEN12164 CW614N
11	Handwheel	Malleable Iron	A-197 F22000
12	ID Plate	Aluminum	
13	Handwheel Nut	Brass	BSEN12164 CW614N

NOTE:

The addition of the letter "K" at the end of the figure number designates valves assembled & tested in the USA. Materials of Construction & Dimensions are the same.

Industry Standards

Complies with MSS SP-80 Type 1

See page 7 for Pressure-Temperature Ratings

Dimensions and Weights

Inches (millimeters) - Pounds (kilograms)

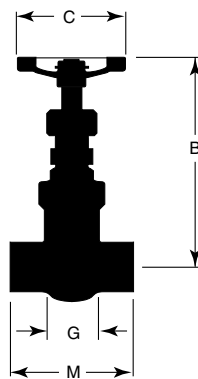

Valve Size	Dimensions				Wt.
	B	C	G*	M	
½	3.23	2.06	0.81	2.00	1.0
	(82)	(52)	(21)	(48)	(0.47)
¾	3.74	2.56	0.86	2.20	1.3
	(95)	(65)	(23)	(62)	(0.60)
1	4.64	2.75	1.04	2.50	2.0
	(118)	(70)	(27)	(73)	(0.92)
1 ¼	5.67	3.06	1.18	2.80	3.1
	(144)	(79)	(30)	(79)	(1.41)
1 ½	6.53	3.62	1.22	2.90	4.2
	(166)	(92)	(31)	(88)	(1.92)
2	7.48	4.06	1.42	3.30	6.0
	(190)	(103)	(36)	(105)	(2.72)
2 ½	9.26	5.28	1.44	4.30	12.4
	(235)	(134)	(37)	(112)	(5.62)
3	9.89	5.28	1.57	4.60	17.4
	(251)	(134)	(40)	(126)	(7.89)

*Piping Make-Up Dimensions

Gate Valve Figure B-105

Class 125 • Union Bonnet • Rising Stem • Threaded Ends

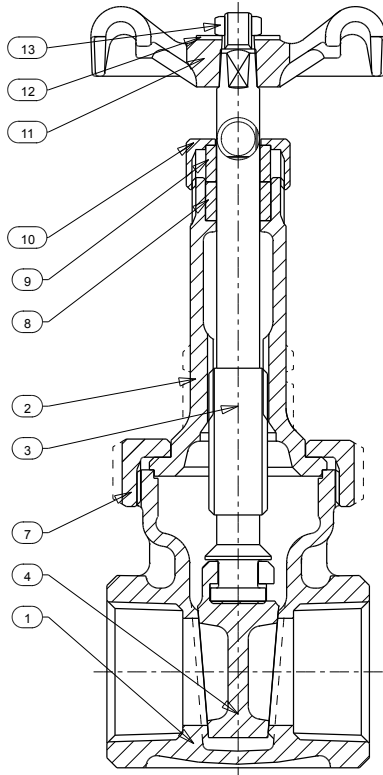

Materials of Construction

No.	Description	Material	ASTM Spec.
1	Body	Bronze	B-62 C83600
2	Bonnet - Union	Bronze	B-62 C83600
3	Stem	Copper Silicon Bronze	B-371 C69400
4	Disc	Bronze	B-62 C83600
7	Union Ring	Bronze	B-62 C83600
8	Packing Ring	Graphite (Asbestos Free)	
9	Gland	Brass	BSEN12164 CW614N
10	Packing Nut	(1/4" - 2") Brass	BSEN12164 CW614N
		(2 1/2" - 3") Bronze	B-62 C83600
11	Handwheel	Malleable Iron	A-197 F22000
12	ID Plate	Aluminum	
13	Handwheel Nut	Brass	BSEN12164 CW614N
14	Gasket	(2 1/2" - 3" only) Synthetic Glass Fiber Nitrile Filled	Klingersil C4500

NOTE:

The addition of the letter "K" at the end of the figure number designates valves assembled & tested in the USA. Materials of Construction & Dimensions are the same.

Industry Standards

Complies with MSS SP-80 Type 2

See page 7 for Pressure-Temperature Ratings

Dimensions and Weights

Inches (millimeters) - Pounds (kilograms)

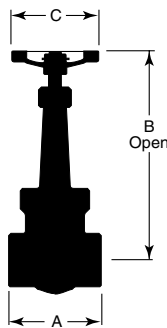

Valve Size	Dimensions			Wt.
	B	C	A	
1/4	4.96	1.75	1.81	0.7
	(126)	(45)	(46)	(0.32)
3/8	4.96	1.75	1.81	0.7
	(126)	(45)	(46)	(0.31)
1/2	5.07	2.06	1.98	1.0
	(129)	(52)	(51)	(0.46)
3/4	6.25	2.56	2.14	1.6
	(159)	(65)	(55)	(0.72)
1	7.44	2.75	2.46	2.4
	(189)	(70)	(63)	(1.10)
1 1/4	8.62	3.06	2.77	3.3
	(219)	(78)	(71)	(1.50)
1 1/2	9.68	3.62	2.85	4.9
	(246)	(92)	(73)	(2.25)
2	11.85	3.62	3.25	7.0
	(301)	(92)	(83)	(3.20)
2 1/2	14.53	5.28	4.25	12.8
	(369)	(134)	(108)	(5.80)
3	16.39	5.28	4.59	18.8
	(416)	(134)	(117)	(8.52)

Gate Valve Figure B-120

Class 150 • Union Bonnet • Rising Stem • Threaded Ends

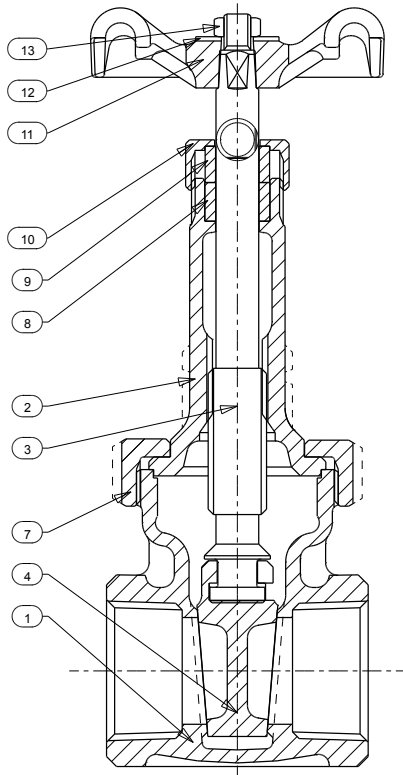

Materials of Construction

No.	Description	Material	ASTM Spec.
1	Body	Bronze	B-62 C83600
2	Bonnet - Union	Bronze	B-62 C83600
3	Stem	Copper Silicon Bronze	B-371 C69400
4	Disc	Bronze	B-62 C83600
7	Union Ring	Bronze	B-62 C83600
8	Packing Ring	Graphite (Asbestos Free)	
9	Gland	Brass	BSEN12164 CW614N
10	Packing Nut	(1/4" - 2") Brass	BSEN12164 CW614N
		(2 1/2" - 3") Bronze	B-62 C83600
11	Handwheel	Malleable Iron	A-197 F22000
12	ID Plate	Aluminum	
13	Handwheel Nut	Brass	BSEN12164 CW614N
14	Gasket	(2 1/2" - 3" only) Synthetic	Klingersil C4500
		Glass Fiber Nitrile Filled	

NOTE:

The addition of the letter "K" at the end of the figure number designates valves assembled & tested in the USA. Materials of Construction & Dimensions are the same.

Industry Standards

Complies with MSS SP-80 Type 2

See page 7 for Pressure-Temperature Ratings

Dimensions and Weights

Inches (millimeters) - Pounds (kilograms)

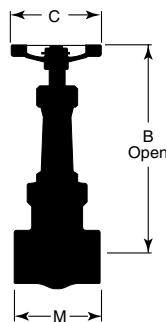

Valve Size	Dimensions			Wt.
	B	C	M	
1/4	4.96	1.75	1.81	0.7
	(126)	(45)	(46)	(0.32)
3/8	4.96	1.75	1.81	0.7
	(126)	(45)	(46)	(0.31)
1/2	5.07	2.06	1.98	1.0
	(129)	(52)	(51)	(0.46)
3/4	6.25	2.56	2.14	1.6
	(159)	(65)	(55)	(0.72)
1	7.44	2.75	2.46	2.4
	(189)	(70)	(63)	(1.10)
1 1/4	8.62	3.06	2.77	3.3
	(219)	(78)	(71)	(1.50)
1 1/2	9.68	3.62	2.85	4.9
	(246)	(92)	(73)	(2.25)
2	11.85	3.62	3.25	7.0
	(301)	(92)	(83)	(3.20)
2 1/2	14.53	5.28	4.25	12.8
	(369)	(134)	(108)	(5.80)
3	16.39	5.28	4.59	18.8
	(416)	(134)	(117)	(8.52)

Gate Valve Figure B-122

Class 150 • Threaded Bonnet • Rising Stem • Threaded Ends

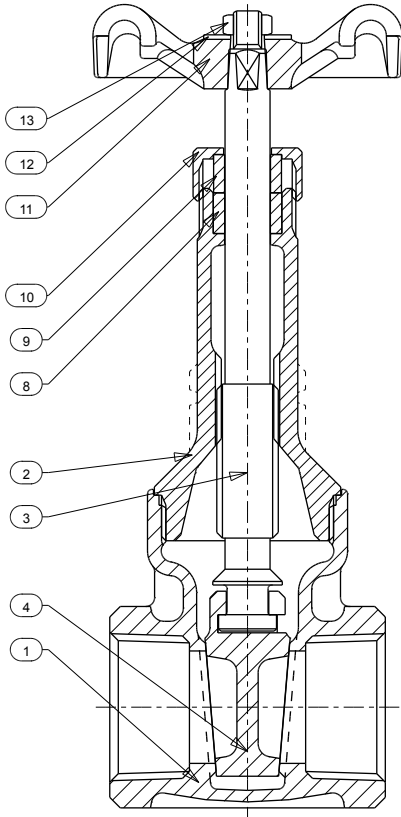

Materials of Construction

No.	Description	Material	ASTM Spec.
1	Body	Bronze	B-62 C83600
2	Bonnet	Bronze	B-62 C83600
3	Stem	Copper Silicon Bronze	B-371 C69400
4	Disc	Bronze	B-62 C83600
8	Packing Ring	Graphite (Asbestos Free)	
9	Gland	Brass	BSEN12164 CW614N
10	Packing Nut	Brass	BSEN12164 CW614N
11	Handwheel	Malleable Iron	A-197 F22000
12	ID Plate	Aluminum	
13	Handwheel Nut	Brass	BSEN12164 CW614N

NOTE:

The addition of the letter "K" at the end of the figure number designates valves assembled & tested in the USA. Materials of Construction & Dimensions are the same.

Industry Standards

Complies with MSS SP-80 Type 2

See page 7 for Pressure-Temperature Ratings

Dimensions and Weights

Inches (millimeters) - Pounds (kilograms)

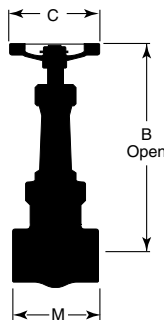

Valve Size	Dimensions			Wt.
	B	C	M	
¼	4.96	1.75	1.81	0.7
	(126)	(45)	(46)	(0.32)
⅜	4.96	1.75	1.81	0.7
	(126)	(45)	(46)	(0.32)
½	5.07	2.06	1.98	1.0
	(129)	(52)	(51)	(0.46)
¾	6.25	2.56	2.14	1.6
	(159)	(65)	(55)	(0.72)
1	7.44	2.75	2.46	2.4
	(189)	(70)	(63)	(1.10)
1 ¼	8.62	3.06	2.77	3.3
	(219)	(78)	(71)	(1.50)
1 ½	9.68	3.62	2.85	4.9
	(246)	(92)	(73)	(2.25)
2	11.85	3.62	3.25	7.0
	(301)	(92)	(83)	(3.20)
2 ½	14.53	5.28	4.25	12.8
	(369)	(134)	(108)	(5.80)
3	16.39	5.28	4.59	18.8
	(416)	(134)	(117)	(8.52)

Gate Valve Figure B-128

Class 150 • Threaded Bonnet • Non-Rising Stem • Threaded Ends

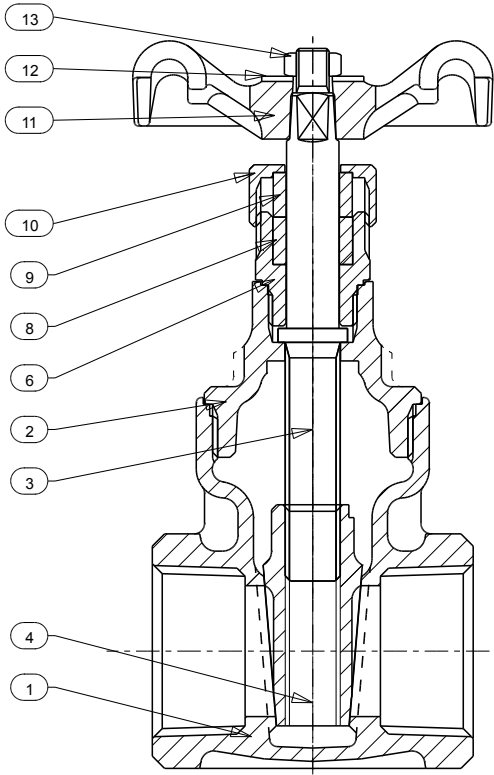

Materials of Construction

No.	Description	Material	ASTM Spec.
1	Body	Bronze	B-62 C83600
2	Bonnet	Bronze	B-62 C83600
3	Stem	Copper Silicon Bronze	B-371 C69400
4	Disc	Bronze	B-62 C83600
6	Stuffing Box	Brass	B-371 C69400
8	Packing Ring	Graphite (Asbestos Free)	
9	Gland	Brass	BSEN12164 CW614N
10	Packing Nut	Brass	BSEN12164 CW614N
11	Handwheel	Malleable Iron	A-197 F22000
12	ID Plate	Aluminum	
13	Handwheel Nut	Brass	BSEN12164 CW614N

NOTE:

The addition of the letter "K" at the end of the figure number designates valves assembled & tested in the USA. Materials of Construction & Dimensions are the same.

Industry Standards

Complies with MSS SP-80 Type 1

See page 7 for Pressure-Temperature Ratings

Dimensions and Weights

Inches (millimeters) - Pounds (kilograms)

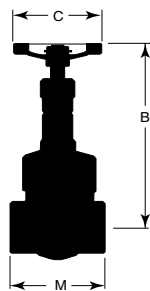

Valve Size	Dimensions			Wt.
	B	C	M	
1/4	2.95	1.75	1.81	0.6
	(75)	(45)	(46)	(0.27)
3/8	2.95	1.75	1.81	0.6
	(75)	(45)	(46)	(0.26)
1/2	3.23	2.06	1.98	0.8
	(82)	(52)	(51)	(0.35)
3/4	3.74	2.56	2.14	1.2
	(95)	(65)	(55)	(0.55)
1	4.64	2.75	2.46	1.8
	(118)	(70)	(63)	(0.84)
1 1/4	5.67	3.06	2.77	2.6
	(144)	(79)	(71)	(1.18)
1 1/2	6.53	3.62	2.85	3.6
	(166)	(92)	(73)	(1.66)
2	7.48	4.06	3.25	5.6
	(190)	(103)	(83)	(2.55)
2 1/2	9.26	5.28	4.25	12.4
	(235)	(134)	(108)	(5.62)
3	9.89	5.28	4.59	17.4
	(251)	(134)	(117)	(7.89)

Gate Valve Figure B-131

Class 150 • Threaded Bonnet • Non-Rising Stem • Flanged Ends

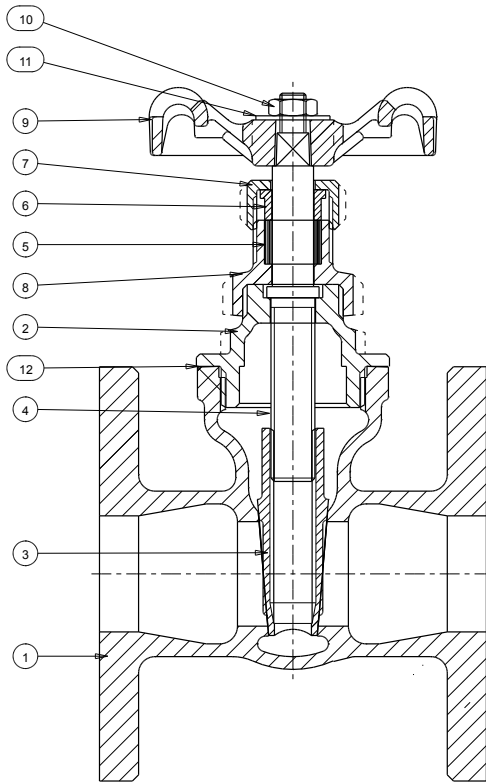

Materials of Construction

No.	Description	Material	ASTM Spec.
1	Body	Bronze	B-62 C83600
2	Bonnet	Bronze	B-62 C83600
3	Disc	Bronze	B-62 C83600
4	Stem	Copper Silicon Bronze	B-371 C69400
5	Packing	Graphite (Asbestos Free)	
6	Gland	Brass	BSEN12164 CW614N
7	Packing Nut	Brass	BSEN12164 CW614N
8	Stem Bush	(1" Copper Silicon Bronze	B-371 C69400
8	Stuffing Box	(1 1/4" - 2") Copper Silicon Bronze	B-371 C69400
		(2 1/2" - 3") Bronze	B-62 C83600
9	Handwheel	Malleable Iron	A-197 F22000
10	Handwheel Nut	Brass	BSEN12164 CW614N
11	ID Plate	Aluminum	
12	Gasket	(3" only) Synthetic Glass Fiber Nitrile Filled	

NOTE:

The addition of the letter "K" at the end of the figure number designates valves assembled & tested in the USA. Materials of Construction & Dimensions are the same.

Industry Standards

Complies with MSS SP-80 Type 1

See page 7 for Pressure-Temperature Ratings

Dimensions and Weights

Inches (millimeters) - Pounds (kilograms)

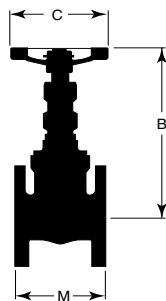

Valve Size	Dimensions			Wt.
	B	C	M	
1	4.88	2.75	3.90	5.71
	(124)	(70)	(99)	(2.59)
1 1/4	5.71	3.63	4.33	6.31
	(145)	(92)	(110)	(2.86)
1 1/2	6.50	3.63	4.72	9.04
	(165)	(92)	(120)	(4.10)
2	7.44	4.06	5.32	12.33
	(189)	(103)	(135)	(5.54)
2 1/2	9.13	4.75	6.50	18.50
	(232)	(121)	(165)	(8.39)
3	10.39	6.00	7.28	25.50
	(264)	(152)	(185)	(11.60)

Gate Valve Figure B-132

Class 200 • Union Bonnet* • Rising Stem • SS Seats • Thrd. Ends

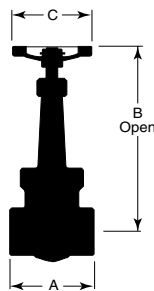
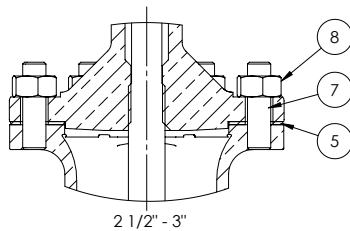
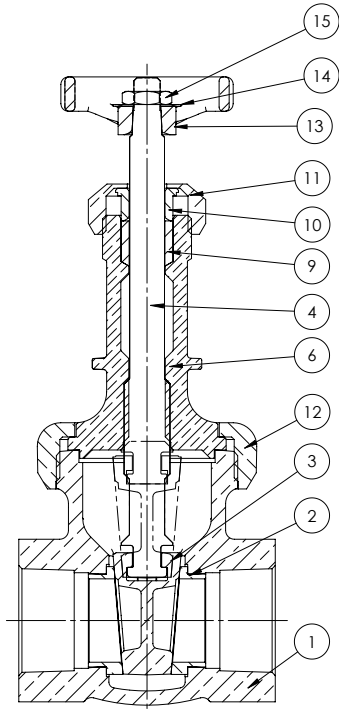

Materials of Construction

No.	Description	Material	ASTM Spec.
1	Body	Bronze	B-61 C92200
2	Body Seat Ring	Stainless Steel	A-276 Type 410
3	Disc	Bronze	B-61 C92200
4	Stem	Bronze	B-371 C69400
5	Gasket	Synthetic/Glass Fiber with Nitrile Binder	
6	Bonnet	Bronze	B-61 C92200
7	Stud	Steel Cadmium	A-109 C1144
8	Stud Nut	Mild Steel	A-563 GR A
9	Packing	Graphite (Asbestos Free)	
10	Gland	Brass	B-16 H02
11	Packing Nut	Brass	B-16 H02
12	Union Bonnet Ring	Bronze	B-61 C92200
13	Handwheel	(1/4" - 2 1/2") Cast Iron (3") Ductile Iron	
14	ID Plate	Steel Zinc Plated	
15	Lock Nut	Steel Cadmium	

NOTE:

The addition of the letter "K" at the end of the figure number designates valves assembled & tested in the USA. Materials of Construction & Dimensions are the same.

Industry Standards

Complies with MSS SP-80 Type 2

See page 7 for Pressure-Temperature Ratings

Dimensions and Weights

Inches (millimeters) - Pounds (kilograms)

Valve Size	Dimensions			Wt.
	B	C	A	
1/4	4.67	2.24	2.03	0.88
	(119)	(57)	(52)	(0.40)
3/8	4.67	2.24	2.13	0.90
	(119)	(57)	(54)	(0.41)
1/2	5.37	2.76	2.44	1.43
	(136)	(70)	(62)	(0.65)
3/4	6.57	2.76	2.61	2.07
	(167)	(70)	(66)	(0.94)
1	7.60	2.76	3.06	3.23
	(193)	(70)	(78)	(1.47)
1 1/4	9.09	4.02	3.35	4.86
	(231)	(102)	(85)	(2.21)
1 1/2	10.28	4.02	3.69	6.18
	(261)	(102)	(94)	(2.81)
2	12.17	4.02	3.96	10.36
	(309)	(102)	(101)	(4.71)
*2 1/2	14.37	4.76	4.60	18.61
	(365)	(121)	(117)	(8.46)
*3	16.68	5.51	5.63	31.33
	(424)	(140)	(143)	(14.24)

* 2 1/2" and 3" have Bolted Bonnet

Gate Valve Figure B-135

Class 200 • Union Bonnet • Rising Stem • Threaded Ends

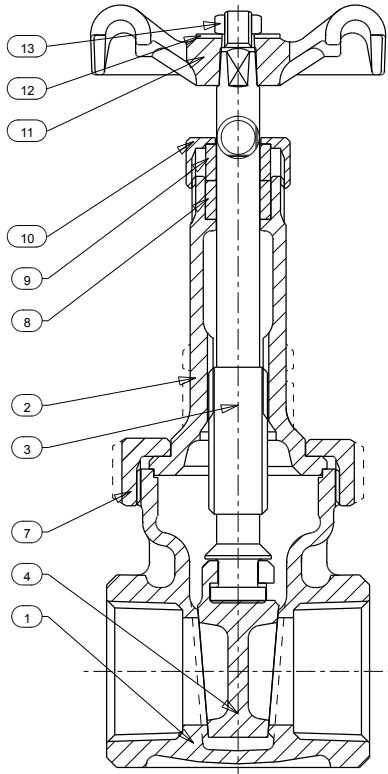

Materials of Construction

No.	Description	Material	ASTM Spec.
1	Body	Bronze	B-61 C92200
2	Bonnet - Union	Bronze	B-61 C92200
3	Stem	Copper Silicon Bronze	B-371 C69400
4	Disc	Bronze	B-61 C92200
7	Union Ring	Bronze	B-62 C83600
8	Packing Ring	Graphite (Asbestos Free)	
9	Gland	Brass	BSEN12164 CW614N
10	Packing Nut	(1/4" - 2") Brass	BSEN12164 CW614N
		(2 1/2" - 3") Bronze	B-62 C83600
11	Handwheel	Malleable Iron	A-197 F22000
12	ID Plate	Aluminum	
13	Handwheel Nut	Brass	BSEN12164 CW614N
14	Gasket	(2 1/2" - 3" only) Synthetic Glass Fiber Nitrile Filled	Klingersil C4500

NOTE:

The addition of the letter "K" at the end of the figure number designates valves assembled & tested in the USA. Materials of Construction & Dimensions are the same.

Industry Standards

Complies with MSS SP-80 Type 2

See page 7 for Pressure-Temperature Ratings

Dimensions and Weights

Inches (millimeters) - Pounds (kilograms)

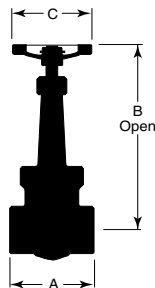

Valve Size	Dimensions			Wt.
	B	C	A	
1/4	4.96	1.75	1.81	0.7
	(126)	(45)	(46)	(0.32)
3/8	4.96	1.75	1.81	0.7
	(126)	(45)	(46)	(0.31)
1/2	5.07	2.06	1.98	1.0
	(129)	(52)	(51)	(0.46)
3/4	6.25	2.56	2.14	1.6
	(159)	(65)	(55)	(0.72)
1	7.44	2.75	2.46	2.4
	(189)	(70)	(63)	(1.10)
1 1/4	8.62	3.06	2.77	3.3
	(219)	(78)	(71)	(1.50)
1 1/2	9.68	3.62	2.85	4.9
	(246)	(92)	(73)	(2.25)
2	11.85	3.62	3.25	7.0
	(301)	(92)	(83)	(3.20)
2 1/2	14.53	5.28	4.25	12.8
	(369)	(134)	(108)	(5.80)
3	16.39	5.28	4.59	18.8
	(416)	(134)	(117)	(8.52)

Gate Valve Figure B-144

Class 300 • Union Bonnet* • Rising Stem • Threaded Ends

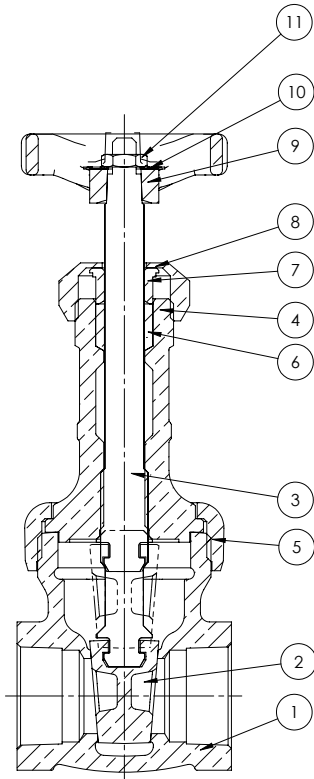

Materials of Construction

No.	Description	Material	ASTM Spec.
1	Body	Bronze	B-61 C92200
2	Disc	Bronze	B-61 C92200
3	Stem	Bronze	B-371 C69400
4	Bonnet	Bronze	B-61 C92200
5	Union Bonnet Ring	Bronze	B-61 C92200
6	Packing	Graphite (Asbestos Free)	
7	Gland	Brass	B-16 H02
8	Packing Nut	(1/4" - 1 1/2") Brass	B-16 H02
		(2" - 3") Brass	B-61 C92200
9	Handwheel	Ductile Iron	
10	ID Plate	Aluminum	
11	Lock Nut	Steel Cadmium	

NOTE:

The addition of the letter "K" at the end of the figure number designates valves assembled & tested in the USA. Materials of Construction & Dimensions are the same.

Industry Standards

Complies with MSS SP-80 Type 2

See page 7 for Pressure-Temperature Ratings

Dimensions and Weights

Inches (millimeters) - Pounds (kilograms)

Valve Size	Dimensions			Wt.
	B	C	A	
1/4	4.65	2.25	1.64	0.79
	(118)	(57)	(42)	(0.36)
3/8	4.65	2.25	1.64	0.77
	(118)	(57)	(42)	(0.35)
1/2	5.37	2.75	2.10	1.28
	(136)	(70)	(53)	(0.58)
3/4	6.56	2.75	2.14	1.85
	(167)	(70)	(54)	(0.84)
1	7.60	2.75	2.47	2.99
	(193)	(70)	(63)	(1.36)
1 1/4	9.09	4.00	3.08	4.40
	(231)	(102)	(78)	(2.00)
1 1/2	10.24	4.00	3.21	5.46
	(260)	(102)	(82)	(2.48)
2	12.14	4.00	3.47	9.70
	(308)	(102)	(88)	(4.41)
*2 1/2	14.65	4.75	4.25	14.83
	(372)	(121)	(108)	(6.74)
*3	16.81	5.50	4.59	22.07
	(427)	(140)	(117)	(10.03)

* 2 1/2" and 3" have Bolted Bonnet

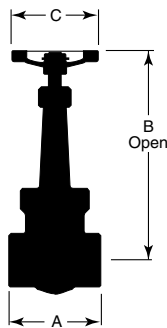

Gate Valve Figure B-145

Class 300 • Union Bonnet* • Rising Stem • SS Seats • Thrd. Ends

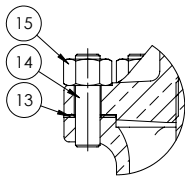
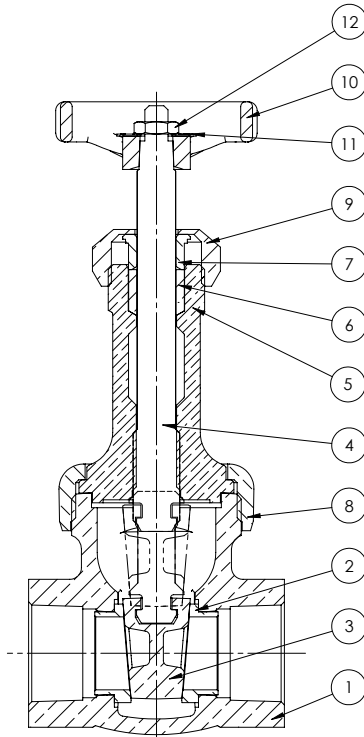

FOR 2 1/2"-3"

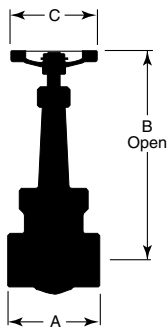

Materials of Construction

No.	Description	Material	ASTM Spec.
1	Body	Bronze	B-61 C92200
2	Body Seat Ring	Stainless Steel	A-276 Type 410
3	Disc	Bronze	B-61 C92200
4	Stem	Bronze	B-371 C69400
5	Bonnet	Bronze	B-61 C92200
6	Packing	Graphite (Asbestos Free)	
7	Gland	Brass	B-16 H02
8	Union Bonnet Ring	Bronze	B-61 C92200
9	Packing Nut	Brass	B-16 H02
10	Handwheel	Cast Iron	
11	ID Plate	Aluminum	
12	Lock Nut	(2 1/2" - 3") Steel Cadmium	
13	Gasket	Synthetic/Glass Fiber with Nitrile Binder	
14	Stud	Steel Cadmium	A-109 C1145
15	Nut	Mild Steel	A-563 GR A

NOTE:

The addition of the letter "K" at the end of the figure number designates valves assembled & tested in the USA. Materials of Construction & Dimensions are the same.

Industry Standards

Complies with MSS SP-80 Type 2

See page 7 for Pressure-Temperature Ratings

Dimensions and Weights

Inches (millimeters) - Pounds (kilograms)

Valve Size	Dimensions			Wt.
	B	C	A	
1/4	4.67	2.24	2.03	0.88
	(119)	(57)	(52)	(0.40)
3/8	7.43	2.24	2.13	0.90
	(189)	(57)	(54)	(0.41)
1/2	5.37	2.76	2.44	1.43
	(136)	(70)	(62)	(0.65)
3/4	6.56	2.76	2.61	2.07
	(167)	(70)	(66)	(0.94)
1	7.60	2.76	3.06	3.23
	(193)	(70)	(78)	(1.47)
1 1/4	9.09	4.02	3.35	4.86
	(231)	(102)	(85)	(2.21)
1 1/2	10.28	4.02	3.69	6.18
	(261)	(102)	(94)	(2.81)
2	12.17	4.02	3.96	10.36
	(309)	(102)	(101)	(4.71)
*2 1/2	14.36	4.75	4.60	19.21
	(365)	(121)	(117)	(8.73)
*3	16.71	5.51	5.63	32.82
	(425)	(140)	(143)	(14.92)

* 2 1/2" and 3" have Bolted Bonnet

Gate Valve Figure B-147

Class 300 • Union Bonnet • Non-Rising Stem • SS Seats • Thrd. Ends

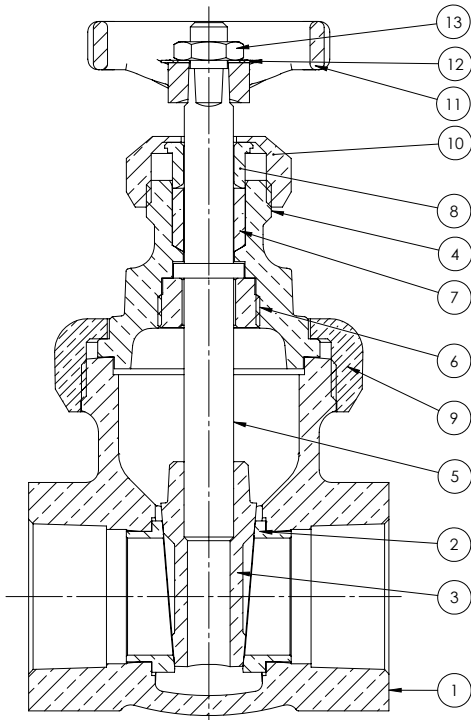

Materials of Construction

No.	Description	Material	ASTM Spec.
1	Body	Bronze	B-61 C92200
2	Disc	Bronze	B-61 C92200
3	Body Seat Ring	Stainless Steel	A-276 Type 410
4	Bonnet	Bronze	B-61 C92200
5	Stem	Bronze	B-371 C69400
6	Stem Retaining Nut	Brass	B-16 H02
7	Packing	Graphite (Asbestos Free)	
8	Gland	Brass	B-16 H02
9	Union Bonnet Ring	Bronze	B-61 C92200
10	Packing Nut	Brass	B-16 H02
11	Handwheel	Ductile Iron	
12	ID Plate	Aluminum	
13	Lock Nut	Steel Cadmium	

NOTE:

The addition of the letter "K" at the end of the figure number designates valves assembled & tested in the USA. Materials of Construction & Dimensions are the same.

Industry Standards

Complies with MSS SP-80 Type 1

See page 7 for Pressure-Temperature Ratings

Dimensions and Weights

Inches (millimeters) - Pounds (kilograms)

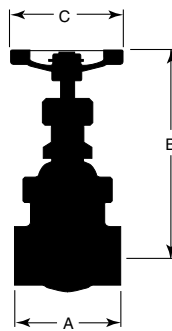

Valve Size	Dimensions			Wt.
	B	C	A	
¼	3.46	2.25	2.03	0.81
	(88)	(57)	(52)	(0.37)
⅜	3.46	2.25	2.13	0.84
	(88)	(57)	(54)	(0.38)
½	3.85	2.75	2.44	1.32
	(98)	(70)	(62)	(0.60)
¾	4.38	2.75	2.61	1.83
	(111)	(70)	(66)	(0.83)
1	4.89	2.75	3.06	2.95
	(124)	(70)	(78)	(1.34)
1 ¼	5.88	4.00	3.35	4.44
	(149)	(102)	(85)	(2.02)
1 ½	6.66	4.00	3.69	5.65
	(169)	(102)	(94)	(2.57)
2	7.51	4.00	3.96	9.61
	(191)	(102)	(101)	(4.37)

Swing Check Valve* Figure B-310BY

200 CWP • Threaded Cap • Viton® Disc • Solder Ends

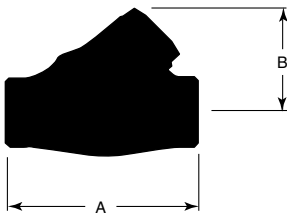
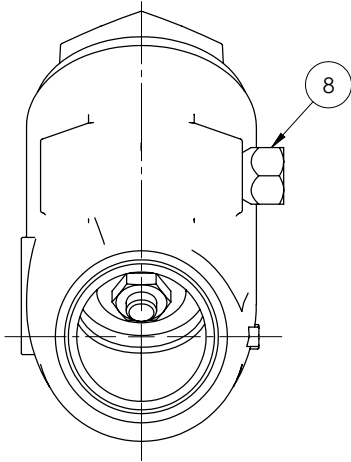
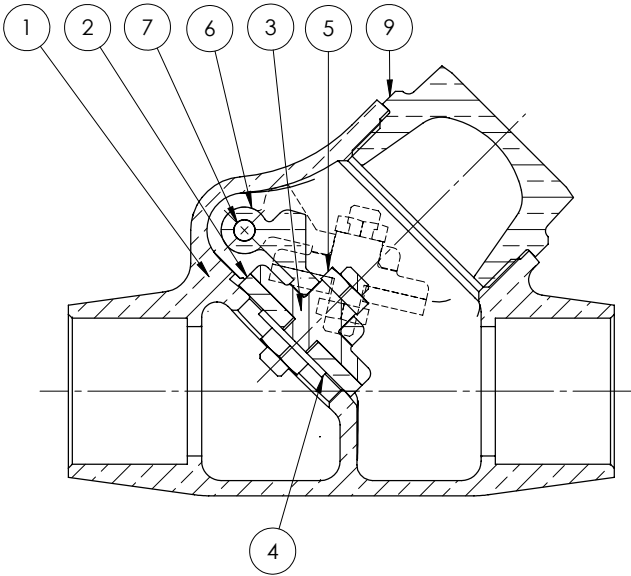

Materials of Construction

No.	Description	Material	ASTM Spec.
1	Body	Bronze	B-62 C83600
2	Disc	Viton® (Viton 90+5 Shore A)	
3	Disc Holder	(1/2" - 3/4") Brass	B-16 H02
		(1" - 2") Bronze	B-62 C83600
4	Disc Washer	Brass	B-16 H02
5	Lock Nut	Brass	B-16 H02
6	Hinge	Bronze	B-584 C87600
7	Hinge Pin	Stainless Steel	A-276 Type 304
8	Hinge Pin Plug	Brass	B-16 H02
9	Cap	Bronze	B-61 C92200

NOTE:

The addition of the letter "K" at the end of the figure number designates valves assembled & tested in the USA. Materials of Construction & Dimensions are the same.

Industry Standards

Complies with MSS SP-80 Type 4

See page 7 for Pressure-Temperature Ratings

Dimensions and Weights

Inches (millimeters) - Pounds (kilograms)

Valve Size	Dimensions		Wt.
	B	A	
1/2	1.64	2.69	0.57
	(42)	(68)	(0.27)
3/4	1.92	3.61	0.95
	(49)	(92)	(0.45)
1	2.52	4.22	1.56
	(64)	(107)	(0.68)
1 1/4	2.95	4.78	2.38
	(75)	(121)	(1.00)
1 1/2	3.43	5.55	3.76
	(87)	(141)	(1.50)
2	4.19	6.85	6.18
	(106)	(174)	(2.45)

* Not recommended for use in reciprocating air compressor service.

Swing Check Valve* Figure B-310TY

200 CWP • Threaded Cap • PTFE Disc • Solder Ends

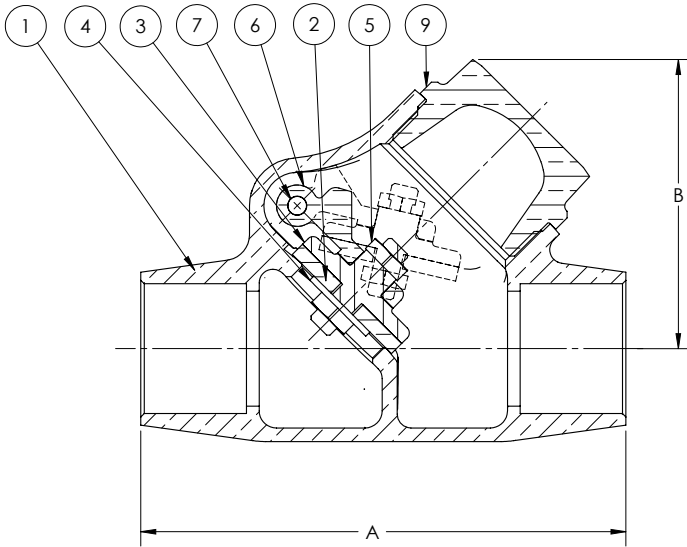

Materials of Construction

No.	Description	Material	ASTM Spec.
1	Body	Bronze	B-62 C83600
2	Disc	PTFE	
3	Disc Holder	(1/2" - 3/4") Brass	B-16 H02
		(1" - 2") Bronze	B-62 C83600
4	Disc Washer	Brass	B-16 H02
5	Lock Nut	Brass	B-16 H02
6	Hinge	Bronze	B-584 C87600
7	Hinge Pin	Stainless Steel	A-276 Type 304
8	Hinge Pin Plug	Brass	B-16 H02
9	Cap	Bronze	B-61 C92200

NOTE:

The addition of the letter "K" at the end of the figure number designates valves assembled & tested in the USA. Materials of Construction & Dimensions are the same.

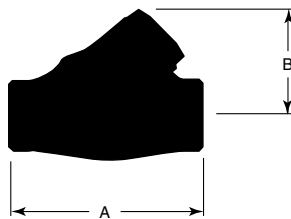
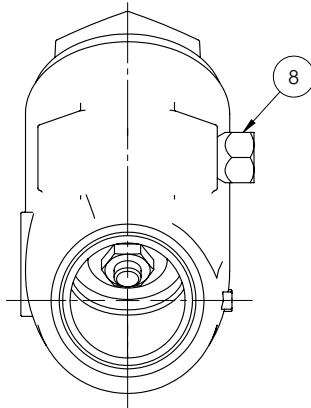

Industry Standards

Complies with MSS SP-80 Type 4

See page 7 for Pressure-Temperature Ratings

Dimensions and Weights

Inches (millimeters) - Pounds (kilograms)

Valve Size	Dimensions		Wt.
	B	A	
1/2	1.64	2.69	0.57 (0.26)
	(42)	(68)	
3/4	1.92	3.61	0.95 (0.43)
	(49)	(92)	
1	2.52	4.22	1.56 (0.71)
	(64)	(107)	
1 1/4	2.95	4.78	2.38 (1.08)
	(75)	(121)	
1 1/2	3.43	5.55	3.76 (1.71)
	(87)	(141)	
2	4.19	6.85	6.18 (2.81)
	(106)	(174)	

* Not recommended for use in reciprocating air compressor service.

Swing Check Valve* Figure B-320BY

Class 125 • Threaded Cap • Viton® Disc • Threaded Ends

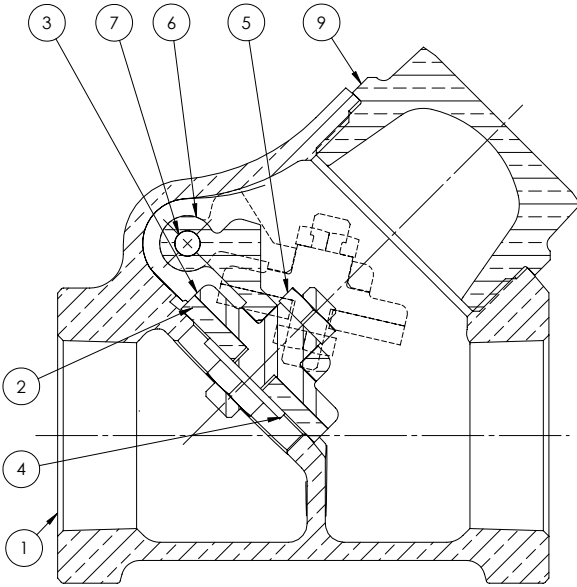

Materials of Construction

No.	Description	Material	ASTM Spec.
1	Body	Bronze	B-62 C83600
2	Disc	Viton®	
3	Disc Holder	(½" - ¾") Brass	B-16 H02
		(1" - 2") Bronze	B-62 C83600
4	Disc Washer	Brass	B-16 H02
5	Lock Nut	Brass	B-16 H02
6	Hinge	Bronze	B-584 C87600
7	Hinge Pin	Stainless Steel	A-276 Type 304
8	Hinge Pin Plug	Brass	B-16 H02
9	Cap	Bronze	B61 C92200

NOTE:

The addition of the letter "K" at the end of the figure number designates valves assembled & tested in the USA. Materials of Construction & Dimensions are the same.

Industry Standards

Complies with MSS SP-80 Type 4

See page 7 for Pressure-Temperature Ratings

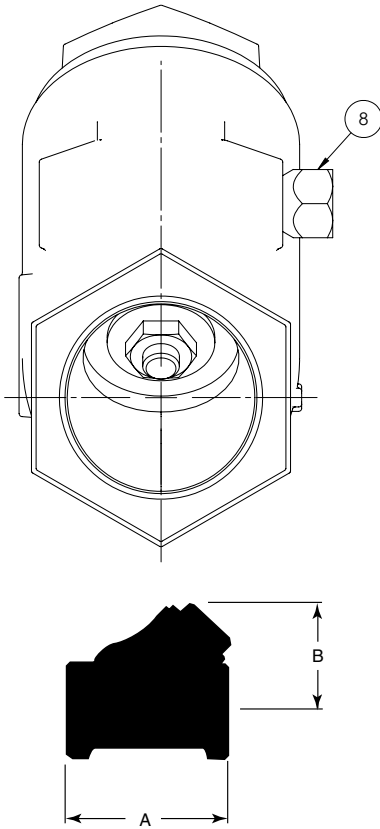

Dimensions and Weights

Inches (millimeters) - Pounds (kilograms)

Valve Size	Dimensions		Wt.
	B	A	
½	1.64	2.15	0.55
	(42)	(55)	(0.25)
¾	1.92	2.71	0.90
	(49)	(69)	(0.41)
1	2.52	3.18	1.45
	(64)	(81)	(0.66)
1 ¼	2.95	3.81	2.29
	(75)	(97)	(1.04)
1 ½	3.43	4.34	3.65
	(87)	(110)	(1.66)
2	4.19	5.11	5.79
	(106)	(130)	(2.63)

* Not recommended for use in reciprocating air compressor service.

Swing Check Valve* Figure B-320TY

Class 125 • Threaded Cap • PTFE Disc • Threaded Ends

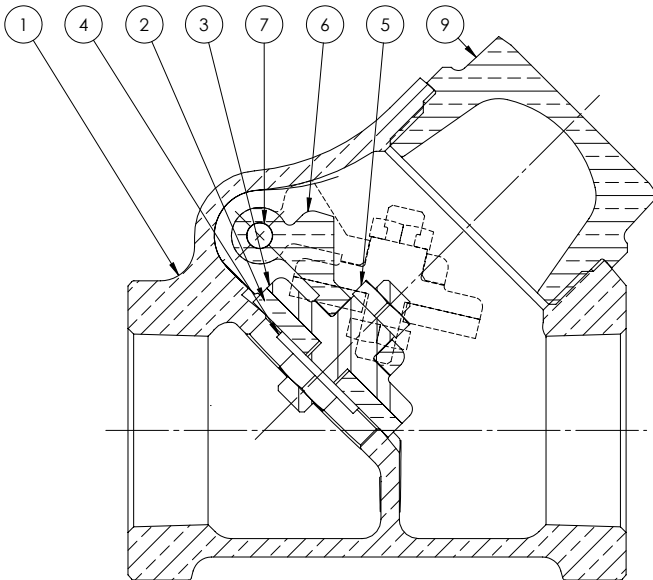

Materials of Construction

No.	Description	Material	ASTM Spec.
1	Body	Bronze	B-62 C83600
2	Disc	PTFE (15% Glass filled)	
3	Disc Holder	(1/2" - 3/4") Brass	B-16 H02
		(1" - 2") Bronze	B-62 C83600
4	Disc Washer	Brass	B-16 H02
5	Lock Nut	Brass	B-16 H02
6	Hinge	Bronze	B-584 C87600
7	Hinge Pin	Stainless Steel	A-276 Type 304
8	Hinge Pin Plug	Brass	B-16 H02
9	Cap	Bronze	B-61 C92200

NOTE:

The addition of the letter "K" at the end of the figure number designates valves assembled & tested in the USA. Materials of Construction & Dimensions are the same.

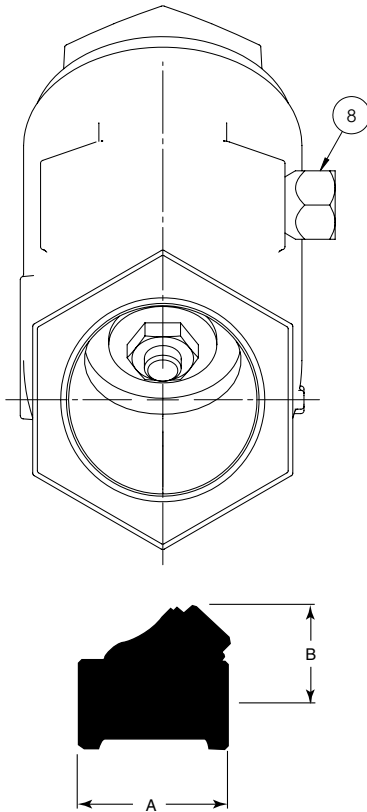

Industry Standards

Complies with MSS SP-80 Type 4

See page 7 for Pressure-Temperature Ratings

Dimensions and Weights

Inches (millimeters) - Pounds (kilograms)

Valve Size	Dimensions		Wt.
	B	A	
1/2	1.64	2.15	0.55
	(42)	(55)	(0.25)
3/4	1.92	2.71	0.90
	(49)	(69)	(0.41)
1	2.52	3.18	1.45
	(64)	(81)	(0.66)
1 1/4	2.95	3.81	2.29
	(75)	(97)	(1.04)
1 1/2	3.43	4.34	3.65
	(87)	(110)	(1.66)
2	4.19	5.11	5.79
	(106)	(130)	(2.63)

* Not recommended for use in reciprocating air compressor service.

Swing Check Valve* Figures B-320BC, B-320TC, B320VC

Class 125 • Bronze Cap • Buna, PTFE, Viton® Disc • Threaded Ends

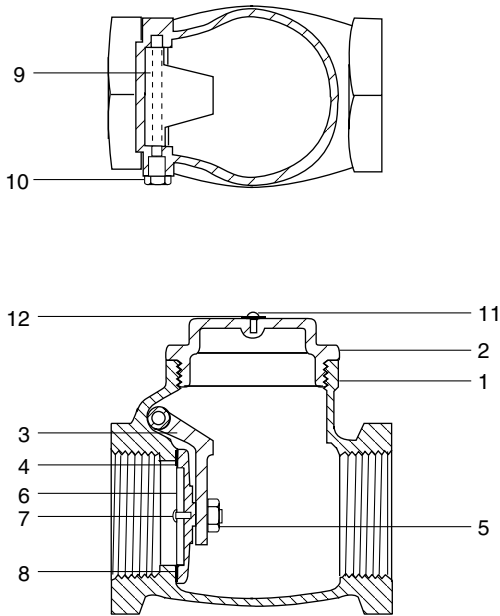

Materials of Construction

No.	Description	Material	ASTM Spec.
1	Body	Bronze	B-62 C83600
2	Cap	Bronze	B-61 C92200
3	Hinge	Bronze	B-62 C83600
4	Disc Holder	Bronze	B-62 C83600
5	Nut	Brass	B-16 C36000
6	Washer	Brass	B-16 C36000
7	Screw	Brass	B-16 C36000
8	Disc	B-320BC Buna-N B-320TC PTFE B-320VC Viton®	
9	Pin	Brass	B-16 C36000
10	Screw	Brass	B-16 C36000
11	Drive Pin	Mild Steel	
12	ID Plate	Aluminum	

NOTE:

Complies with MSS SP-80, Type 4

Dimensions and Weights

Inches (Millimeters) - Pounds (Kilograms)

Valve Size	Dimensions		Wt.
	B	M	
1/4	1.50	2.12	0.70
	(38)	(54)	(0.32)
3/8	1.50	2.12	0.70
	(38)	(54)	(0.32)
1/2	1.77	2.60	0.80
	(45)	(66)	(0.36)
3/4	1.93	2.75	1.00
	(49)	(70)	(0.45)
1	2.28	3.27	1.40
	(58)	(83)	(0.63)
1 1/4	2.56	3.78	2.70
	(65)	(96)	(1.22)
1 1/2	2.87	4.25	2.90
	(73)	(108)	(1.31)
2	3.50	5.04	4.40
	(89)	(128)	(1.98)
2 1/2	4.25	6.30	7.60
	(108)	(160)	(3.42)
3	4.84	7.09	9.30
	(123)	(180)	(4.19)

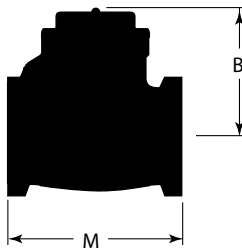

* Not recommended for use in reciprocating air compressor service.

Swing Check Valve* Figure B-309Y

200 CWP • Threaded Cap • Brass/Bronze Disc • Solder Ends

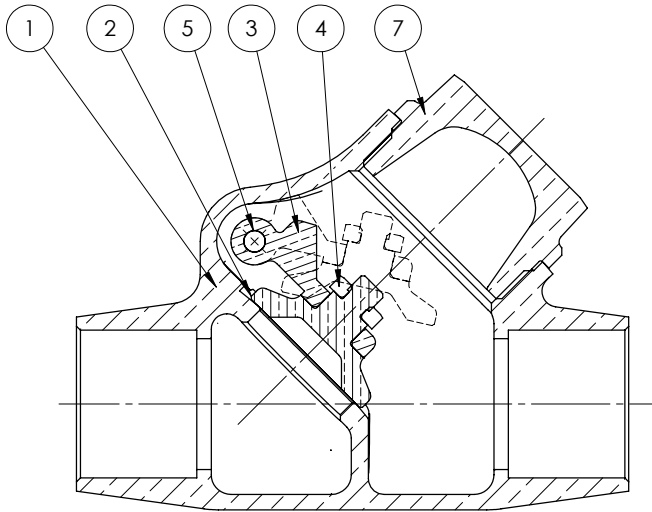

Materials of Construction

No.	Description	Material	ASTM Spec.
1	Body	Bronze	B-62 C83600
2	Disc	(½" - ¾") Brass	B-16 H02
		(1" - 2") Bronze	B-61 C92200
		(2 ½" - 3") Bronze	B-62 C83600
3	Hinge	Bronze	B-584 C87600
4	Lock Nut	Brass	B-16 H02
5	Hinge Pin	Stainless Steel	A-276 C304
6	Hinge Pin Plug	Brass	B-16 H02
7	Cap	Bronze	B-61 C92200

NOTE:

The addition of the letter "K" at the end of the figure number designates valves assembled & tested in the USA. Materials of Construction & Dimensions are the same.

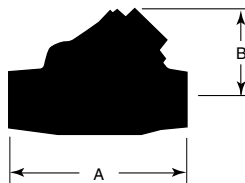
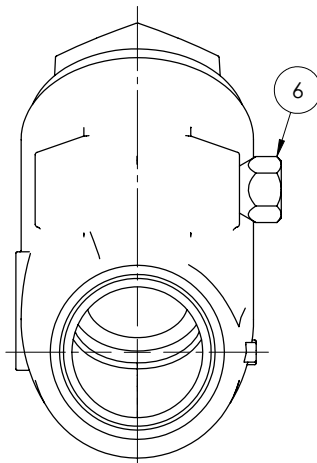

Industry Standards

Complies with MSS SP-80 Type 3

See page 7 for Pressure-Temperature Ratings

Dimensions and Weights

Inches (Millimeters) - Pounds (Kilograms)

Valve Size	Dimensions		Wt.
	B	A	
½	1.64	2.69	0.57
	(42)	(68)	(0.26)
¾	1.92	3.61	0.95
	(49)	(92)	(0.43)
1	2.52	4.22	1.54
	(64)	(107)	(0.70)
1 ¼	2.95	4.81	2.35
	(75)	(122)	(1.07)
1 ½	3.43	5.58	3.72
	(87)	(142)	(1.69)
2	4.19	6.85	6.12
	(106)	(174)	(2.78)
2 ½	5.04	7.78	9.31
	(128)	(198)	(4.23)
3	5.98	9.19	14.10
	(152)	(233)	(6.41)

* Not recommended for use in reciprocating air compressor service.

Swing Check Valve* Figure B-319Y

Class 125 • Threaded Cap • Brass/Bonze Disc • Threaded Ends

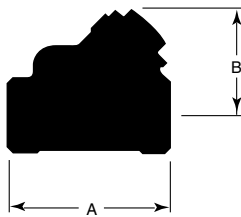
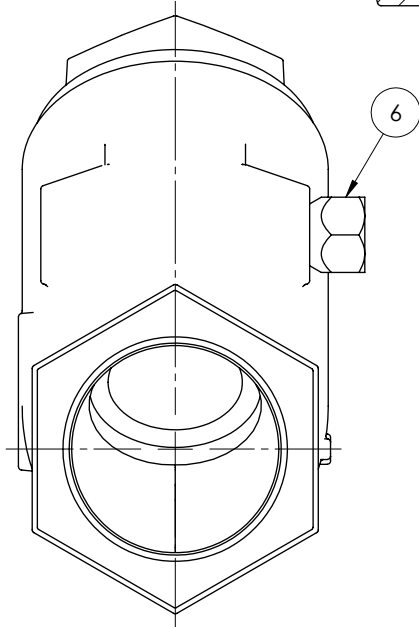
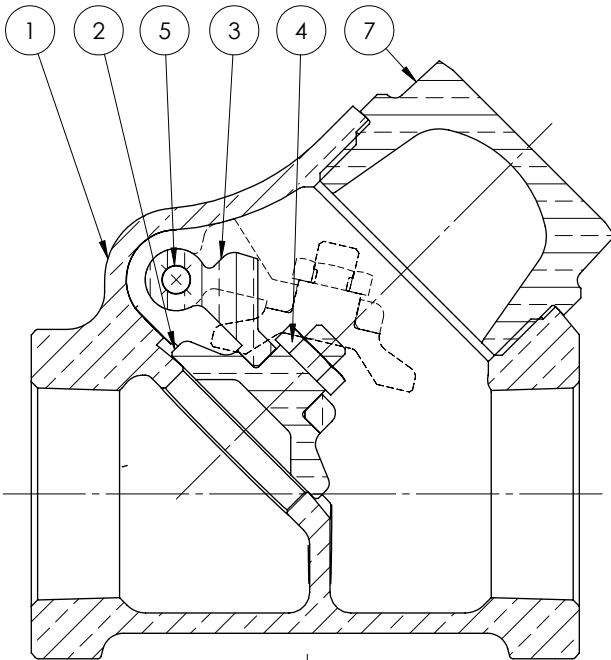

Materials of Construction

No.	Description	Material	ASTM Spec.
1	Body	Bronze	B-61 C92200
2	Disc	(1/4" - 3/4") Brass	B-16 H02
		(1" - 2") Bronze	B-61 C92200
		(2 1/2" - 3") Bronze	B-62 C83600
3	Hinge	Bronze	B-584 C87600
4	Lock Nut	Brass	B-16 H02
5	Hinge Pin	Stainless Steel	A-276 Type 304
6	Hinge Pin Plug	Brass	B-16 H02
7	Cap	Bronze	B-61 C92200

NOTE:

The addition of the letter "K" at the end of the figure number designates valves assembled & tested in the USA. Materials of Construction & Dimensions are the same.

Industry Standards

Complies with MSS SP-80 Type 3

See page 7 for Pressure-Temperature Ratings

Dimensions and Weights

Inches (millimeters) - Pounds (kilograms)

Valve Size	Dimensions		Wt.
	B	A	
1/4	1.49	2.14	0.48
	(38)	(54)	(0.22)
3/8	1.49	2.14	0.46
	(38)	(54)	(0.21)
1/2	1.64	2.15	0.57
	(42)	(55)	(0.26)
3/4	1.92	2.71	0.90
	(49)	(69)	(0.41)
1	2.52	3.18	1.43
	(64)	(81)	(0.65)
1 1/4	2.95	3.81	2.27
	(75)	(97)	(1.03)
1 1/2	3.43	4.34	3.61
	(87)	(110)	(1.64)
2	4.19	5.11	5.70
	(106)	(130)	(2.59)
2 1/2	5.04	6.12	9.09
	(128)	(155)	(4.13)
3	5.97	7.25	14.59
	(152)	(184)	(6.63)

* Not recommended for use in reciprocating air compressor service.

Lift Check Valve Figure B-316

Class 125 • Threaded Cap • Brass/Bronze Disc • Threaded Ends

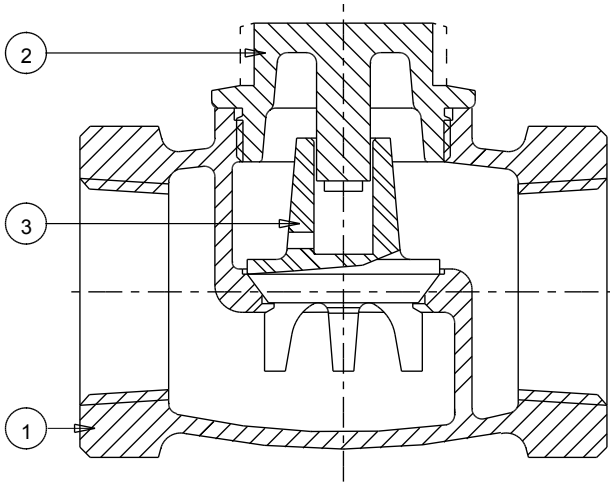

Materials of Construction

No.	Description	Material	ASTM Spec.
1	Body	Bronze	B-62 C83600
2	Cap	(1/2") Brass	BSEN12164 CW614N
		(3/4" - 2") Bronze	B-62 C83600
3	Disc	(1/2" - 3/4") Brass	B-371 C69400
		(1" - 2") Bronze	B-62 C83600

NOTE:

The addition of the letter "K" at the end of the figure number designates valves assembled & tested in the USA. Materials of Construction & Dimensions are the same.

Industry Standards

Complies with MSS SP-80 Type 1

See page 7 for Pressure-Temperature Ratings

Dimensions and Weights

Inches (millimeters) - Pounds (kilograms)

Valve Size	Dimensions		Wt.
	L	T	
1/2	2.17	1.30	0.53
	(55)	(33)	(0.24)
3/4	2.48	1.30	0.77
	(63)	(33)	(0.35)
1	3.03	1.54	1.32
	(77)	(39)	(0.60)
1 1/4	3.58	1.85	2.14
	(91)	(47)	(0.97)
1 1/2	3.86	2.13	2.78
	(98)	(54)	(1.26)
2	4.65	2.56	4.61
	(118)	(65)	(2.09)

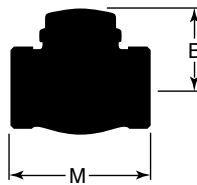

Lift Check Valve Figure B-322B

Class 150 • Union Cap • Buna-N Disc • Threaded Ends

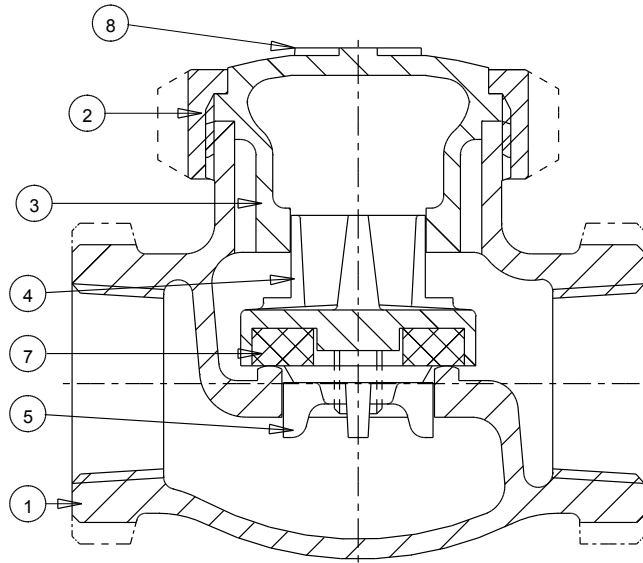

Materials of Construction

No.	Description	Material	ASTM Spec.
1	Body	Bronze	B-62 C83600
2	Union Ring	Bronze	B-62 C83600
3	Cap	Bronze	B-62 C83600
4	Disc Holder	Bronze	B-62 C83600
5	Disc Retaining Nut	(1/4" - 3/8") Brass	BSEN 12164 CW614N
		(1/2" - 2") Bronze	B-62 C83600
7	Washer	(1/4" - 3/8") Brass	BSEN 12164 CW614N
8	Disc	Nitrile	

NOTE:

The addition of the letter "K" at the end of the figure number designates valves assembled & tested in the USA. Materials of Construction & Dimensions are the same.

Industry Standards

Complies with MSS SP-80 Type 2

See page 7 for Pressure-Temperature Ratings

Dimensions and Weights

Inches (millimeters) - Pounds (kilograms)

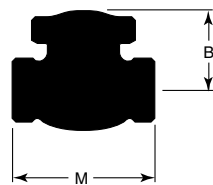

Valve Size	Dimensions		Wt.
	B	M	
1/4	1.46	2.32	0.82
	(37)	(59)	(0.37)
3/8	1.46	2.32	0.79
	(37)	(59)	(0.36)
1/2	1.69	2.68	1.13
	(43)	(68)	(0.51)
3/4	1.93	3.19	1.87
	(49)	(81)	(0.85)
1	2.21	3.74	2.91
	(56)	(95)	(1.32)
1 1/4	2.56	4.25	4.35
	(65)	(108)	(1.97)
1 1/2	2.87	4.76	5.84
	(73)	(121)	(2.65)
2	3.43	5.75	9.79
	(87)	(146)	(4.44)

Lift Check Valve Figure B-322T

Class 150 • Union Cap • PTFE Disc • Threaded Ends

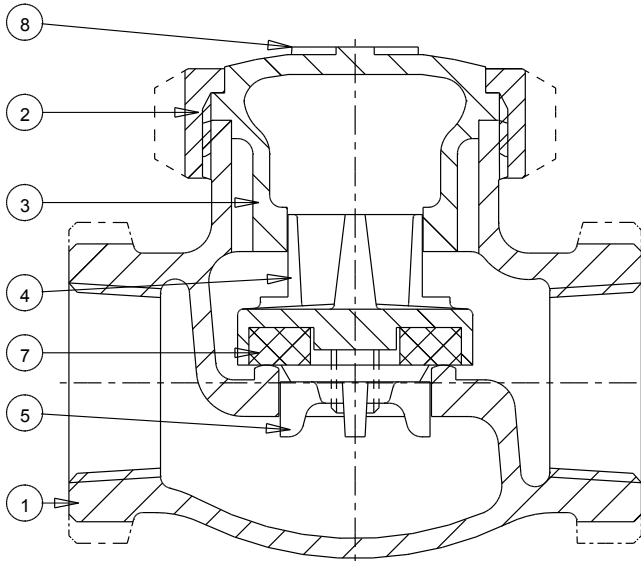

Materials of Construction

No.	Description	Material	ASTM Spec.
1	Body	Bronze	B-62 C83600
2	Union Ring	Bronze	B-62 C83600
3	Cap	Bronze	B-62 C83600
4	Disc Holder	Bronze	B-62 C83600
5	Disc Retaining Nut	($\frac{1}{4}$ " - $\frac{3}{8}$ ") Brass ($\frac{1}{2}$ " - 2") Bronze	BSEN12164 CW614N B-62 C83600
7	Washer	($\frac{1}{4}$ " - $\frac{3}{8}$ ") Brass	BSEN12164 CW614N
8	Disc	PTFE	

Industry Standards

Complies with MSS SP-80 Type 2

See page 7 for Pressure-Temperature Ratings

Dimensions and Weights

Inches (millimeters) - Pounds (kilograms)

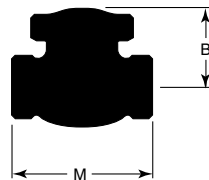

Valve Size	Dimensions		Wt.
	B	M	
$\frac{1}{4}$	1.46	2.32	0.82
	(37)	(59)	(0.37)
$\frac{3}{8}$	1.46	2.32	0.79
	(37)	(59)	(0.36)
$\frac{1}{2}$	1.69	2.68	1.13
	(43)	(68)	(0.51)
$\frac{3}{4}$	1.93	3.19	1.87
	(49)	(81)	(0.85)
1	2.21	3.74	2.91
	(56)	(95)	(1.32)
1 $\frac{1}{4}$	2.56	4.25	4.35
	(65)	(108)	(1.97)
1 $\frac{1}{2}$	2.87	4.76	5.84
	(73)	(121)	(2.65)
2	3.43	5.75	9.79
	(87)	(146)	(4.44)

Swing Check Valve* Figure B-321

Class 150 • Threaded Cap • Brass/Bronze Disc • Threaded Ends

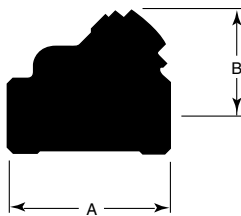
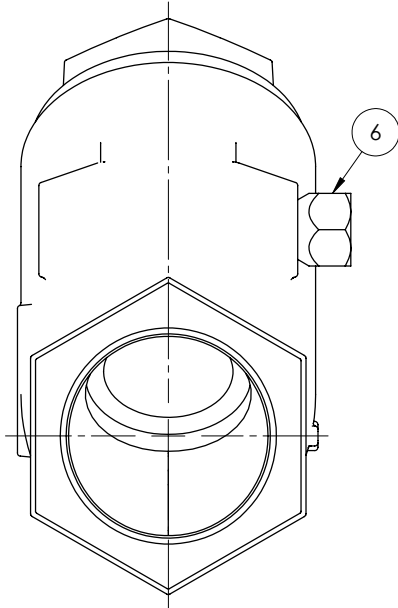
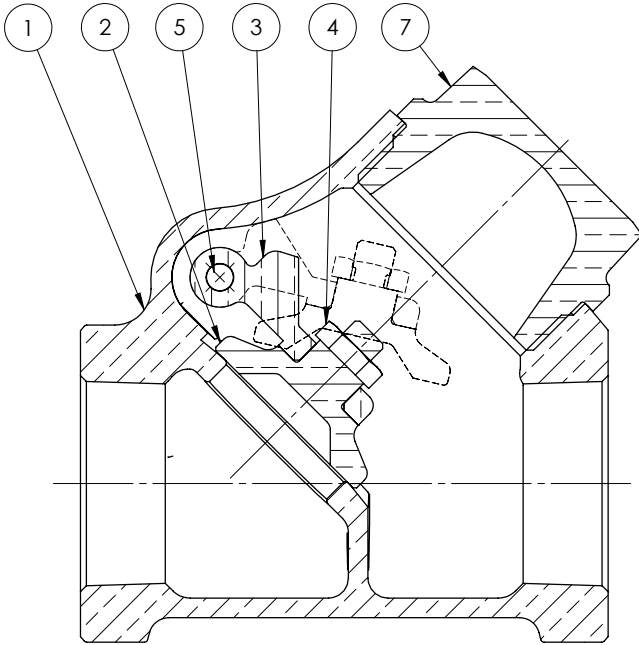

Materials of Construction

No.	Description	Material	ASTM Spec.
1	Body	(1/4" - 3/8") Bronze	B-61 C92200
		(1/2" - 3") Bronze	B-62 C83600
2	Disc	(1/4" - 3/4") Brass	B-16 H02
		(1" - 2") Bronze	B-61 C92200
		(2 1/2" - 3") Bronze	B-62 C83600
3	Hinge	Bronze	B-584 C87600
4	Lock Nut	Brass	B-16 H02
5	Hinge Pin	Stainless Steel	A-276 Type 304
6	Hinge Pin Plug	Brass	B-16 H02
7	Cap	Bronze	B-61 C92200

NOTE:

The addition of the letter "K" at the end of the figure number designates valves assembled & tested in the USA. Materials of Construction & Dimensions are the same.

Industry Standards

Complies with MSS SP-80 Type 3

See page 7 for Pressure-Temperature Ratings

Dimensions and Weights

Inches (millimeters) - Pounds (kilograms)

Valve Size	Dimensions		Wt.
	B	A	
1/4	1.49	2.14	0.50
	(38)	(54)	(0.23)
3/8	1.49	2.14	0.50
	(38)	(54)	(0.23)
1/2	1.64	2.15	0.60
	(42)	(55)	(0.27)
3/4	1.92	2.71	1.00
	(49)	(69)	(0.45)
1	2.52	3.18	1.50
	(64)	(81)	(0.68)
1 1/4	2.95	3.81	2.20
	(75)	(97)	(1.00)
1 1/2	3.43	4.34	3.40
	(87)	(110)	(1.55)
2	4.19	5.11	5.40
	(106)	(130)	(2.45)
2 1/2	5.04	6.12	9.00
	(128)	(155)	(4.09)
3	5.97	7.25	14.50
	(152)	(184)	(6.59)

* Not recommended for use in reciprocating air compressor service.

Lift Check Valve Figure B-337

Class 200 • Union Cap • Bronze Disc • Threaded Ends

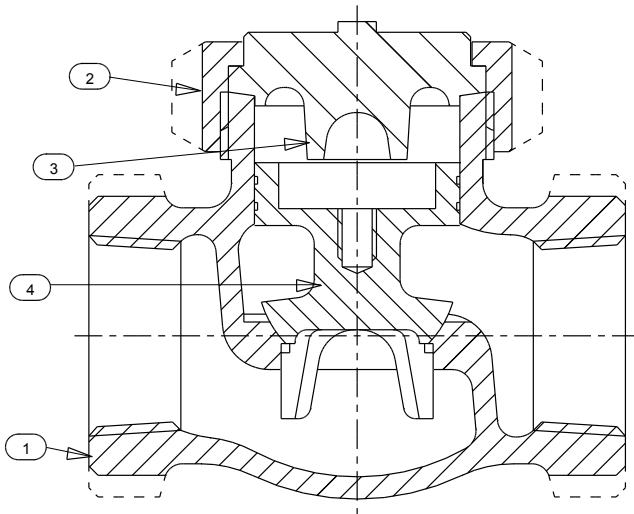

Materials of Construction

No.	Description	Material	ASTM Spec.
1	Body	Bronze	B-61 C92200
2	Union Ring	Bronze	B-62 C83600
3	Cap	(1/2") Copper Silicon Bronze	B-371 C69400
		(3/4" - 2") Bronze	B-61 C92200
4	Disc	Bronze	B-61 C92200

NOTE:

The addition of the letter "K" at the end of the figure number designates valves assembled & tested in the USA. Materials of Construction & Dimensions are the same.

Industry Standards

Complies with MSS SP-80 Type 1

See page 7 for Pressure-Temperature Ratings

Dimensions and Weights

Inches (millimeters) - Pounds (kilograms)

Valve Size	Dimensions		Wt.
	B	M	
1/2	1.46	2.56	1.04
	(37)	(65)	(0.47)
3/4	1.85	2.95	1.70
	(47)	(75)	(0.77)
1	2.05	3.50	2.69
	(52)	(89)	(1.21)
1 1/4	2.36	4.06	4.08
	(60)	(103)	(1.85)
1 1/2	2.64	4.61	5.84
	(67)	(117)	(2.65)
2	3.23	5.75	10.06
	(82)	(146)	(4.56)

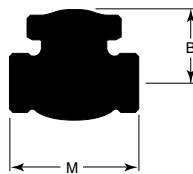

Swing Check Valve* Figure B-345

Class 200 • Threaded Cap • Brass/Bronze Disc • Threaded Ends

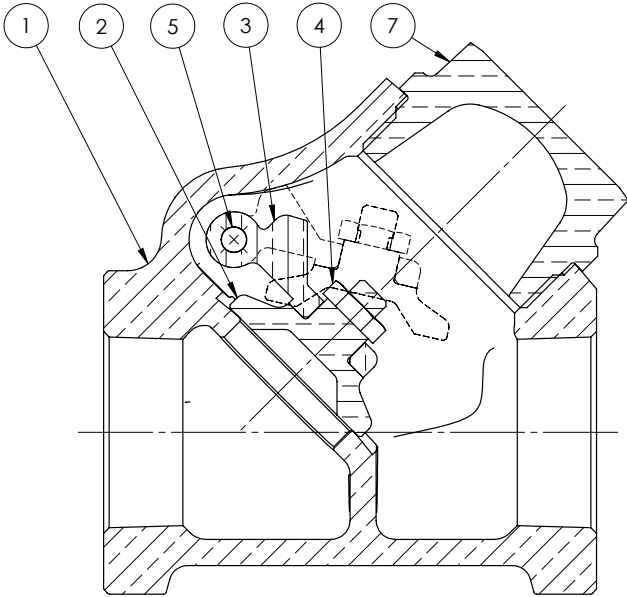

Materials of Construction

No.	Description	Material	ASTM Spec.
1	Body	Bronze	B-61 C92200
2	Disc	(1/4" - 3/4") Brass	B-16 H02
		(1" - 3") Bronze	B-61 C92200
3	Hinge	Bronze	B-584 C87600
4	Lock Nut	Brass	B-16 H02
5	Hinge Pin	Stainless Steel	A-276 C304
6	Hinge Pin Plug	Brass	B-16 H02
7	Cap	Bronze	B-61 C92200

NOTE:

The addition of the letter "K" at the end of the figure number designates valves assembled & tested in the USA. Materials of Construction & Dimensions are the same.

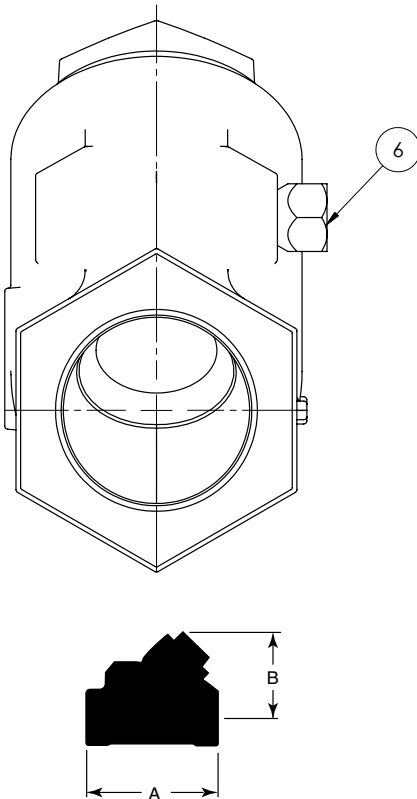

Industry Standards

Complies with MSS SP-80 Type 3

See page 7 for Pressure-Temperature Ratings

Dimensions and Weights

Inches (millimeters) - Pounds (kilograms)

Valve Size	Dimensions		Wt.
	B	A	
1/4	1.49	2.14	0.48
	(38)	(54)	(0.22)
3/8	1.49	2.14	0.46
	(38)	(54)	(0.21)
1/2	1.64	2.15	0.62
	(42)	(55)	(0.28)
3/4	1.92	2.71	1.10
	(49)	(69)	(0.50)
1	2.52	3.18	1.78
	(64)	(81)	(0.81)
1 1/4	2.95	3.81	2.68
	(75)	(97)	(1.22)
1 1/2	3.43	4.34	4.05
	(87)	(110)	(1.84)
2	4.19	5.11	6.67
	(106)	(130)	(3.03)
2 1/2	4.89	6.94	13.00
	(124)	(176)	(5.91)
3	5.88	8.39	21.67
	(149)	(213)	(9.85)

* Not recommended for use in reciprocating air compressor service.

Swing Check Valve* Figure B-375

Class 300 • Threaded Cap • Brass/Bronze Disc • Threaded Ends

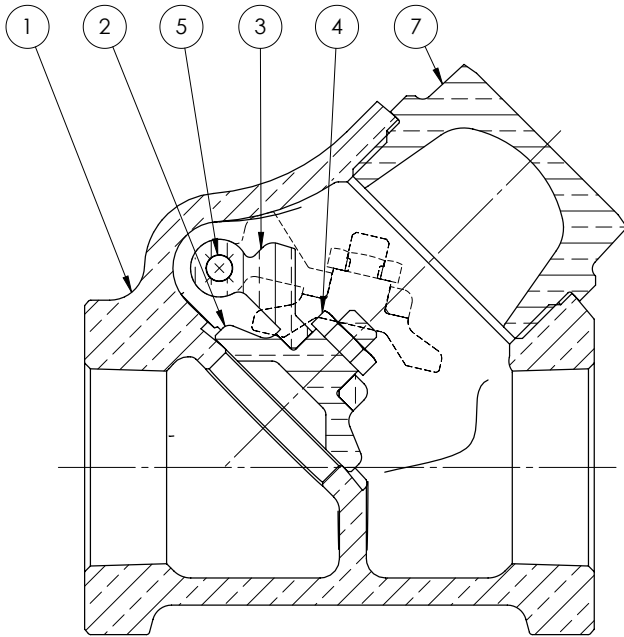

Materials of Construction

No.	Description	Material	ASTM Spec.
1	Body	Bronze	B-61 C92200
2	Disc	(1/4" - 3/4") Brass	B-16 H02
		(1" - 3") Bronze	B-61 C92200
3	Hinge	Bronze	B-584 C87600
4	Lock Nut	Brass	B-16 H02
5	Hinge Pin	Stainless Steel	A-276 C304
6	Hinge Pin Plug	Brass	B-16 H02
7	Cap	Bronze	B-61 C92200

NOTE:

The addition of the letter "K" at the end of the figure number designates valves assembled & tested in the USA. Materials of Construction & Dimensions are the same.

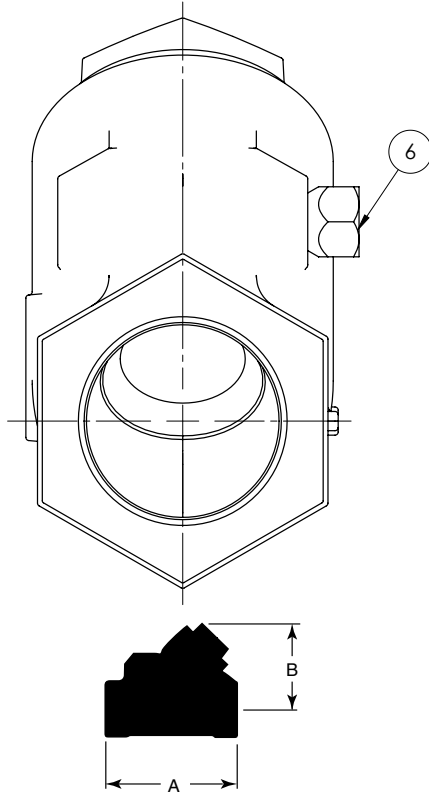

Industry Standards

Complies with MSS SP-80 Type 3

See page 7 for Pressure-Temperature Ratings

Dimensions and Weights

Inches (millimeters) - Pounds (kilograms)

Valve Size	Dimensions		Wt.
	B	A	
1/4	1.49	2.14	0.48
	(38)	(54)	(0.22)
3/8	1.49	2.14	0.46
	(38)	(54)	(0.21)
1/2	1.64	2.15	0.62
	(42)	(55)	(0.28)
3/4	1.92	2.71	1.10
	(49)	(69)	(0.50)
1	2.52	3.18	1.78
	(64)	(81)	(0.81)
1 1/4	2.95	3.81	2.68
	(75)	(97)	(1.22)
1 1/2	3.43	4.34	4.05
	(87)	(110)	(1.84)
2	4.19	5.11	6.67
	(106)	(130)	(3.03)
2 1/2	4.89	6.94	13.00
	(124)	(176)	(5.91)
3	5.88	8.39	21.67
	(149)	(213)	(9.85)

* Not recommended for use in reciprocating air compressor service.

Lift Check Valve Figure B-367

Class 300 • Union Cap • Bronze Disc • Threaded Ends

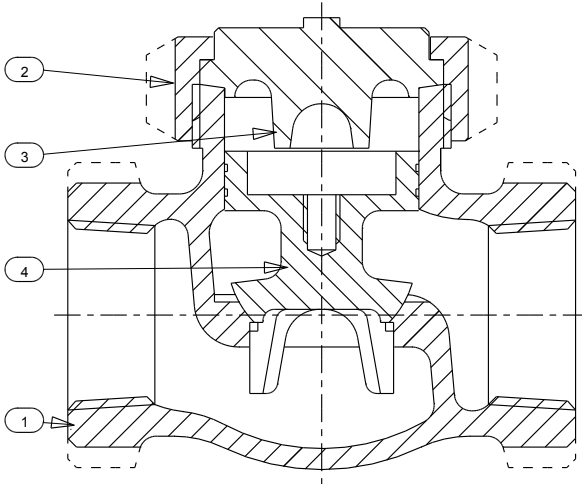

Materials of Construction

No.	Description	Material	ASTM Spec.
1	Body	Bronze	B-61 C92200
2	Union Ring	Bronze	B-62 C83600
3	Cap	(1/2") Copper Silicon Bronze	B-371 C69400
		(3/4" - 2") Bronze	B-61 C92200
4	Disc	Bronze	B-61 C92200

Industry Standards

Complies with MSS SP-80 Type 1

See page 7 for Pressure-Temperature Ratings

Dimensions and Weights

Inches (millimeters) - Pounds (kilograms)

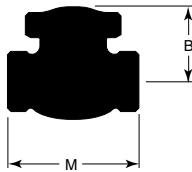

Valve Size	Dimensions		Wt.
	B	M	
1/2	1.46	2.56	1.04
	(37)	(65)	(0.47)
3/4	1.85	2.95	1.70
	(47)	(75)	(0.77)
1	2.05	3.50	2.69
	(52)	(89)	(1.21)
1 1/4	2.36	4.06	4.08
	(60)	(103)	(1.85)
1 1/2	2.64	4.61	5.84
	(67)	(117)	(2.65)
2	3.23	5.75	10.06
	(82)	(146)	(4.56)

Bronze Low Lead Valve Index

Bronze Low Lead Valves
Gate Valves
Class 125 / 200 CWP 58-59

Swing Check Valves
Class 125 / 200 CWP 60-61

Low Lead Gate Valve Figure LFB-103

Class 125 • 200 WOG • Screw Over Bonnet • Solid Disc • Thrd. Ends

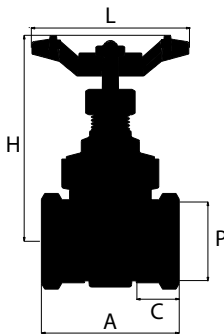
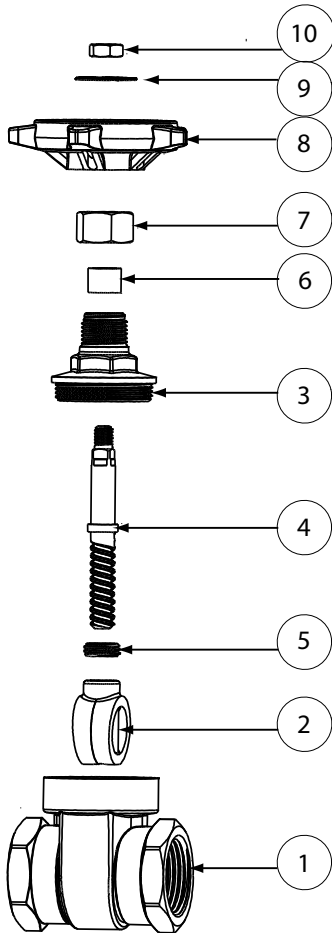

Materials of Construction

No.	Description	Material	Specification
1	Body	Low Lead Brass	CW510L
2	Wedge	Low Lead Brass	CW510L
3	Bonnet	Low Lead Brass	CW510L
4	Stem	Low Lead Brass	CW510L
5	Ring	Low Lead Brass	CW510L
6	Packing Ring	Graphite	WRAS Approved
7	Packing Nut	Brass	BS2874 CZ122
8	Handwheel	Aluminum	B85 Red Painted
9	Disc	Aluminum	B85
10	Nut	Zinc Plated Steel	A36

Industry Standards

Meet the requirements of California's AB1953
and in full compliance with NSF61 Annex G.

Dimensions and Weights

Inches (millimeters) - Pounds (kilograms)

Valve Size	Dimensions					Wt.	Cv
	A	C	H	L	P		
½	1.97	0.65	2.79	2.51	0.51	0.53	10.8
	(50)	(17)	(71)	(64)	(13)	(0.24)	
¾	2.12	0.65	3.17	2.51	0.74	0.82	23
	(54)	(17)	(81)	(64)	(19)	(0.37)	
1	2.44	0.78	3.93	2.99	1.00	1.17	42
	(62)	(20)	(100)	(76)	(25)	(0.53)	
1 ¼	2.75	0.86	4.37	3.54	1.25	1.83	72
	(70)	(22)	(111)	(90)	(32)	(0.83)	
1 ½	2.84	0.86	4.94	3.54	1.50	2.38	120
	(72)	(22)	(125)	(90)	(38)	(1.08)	
2	3.23	0.86	6.27	4.13	2.00	4.03	210
	(82)	(22)	(159)	(105)	(51)	(1.82)	

Low Lead Gate Valve Figure LFB-104

Class 125 WSP • 200 WOG • Screw Over Bonnet • Solid Disc • Solder

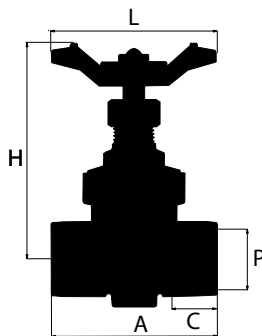
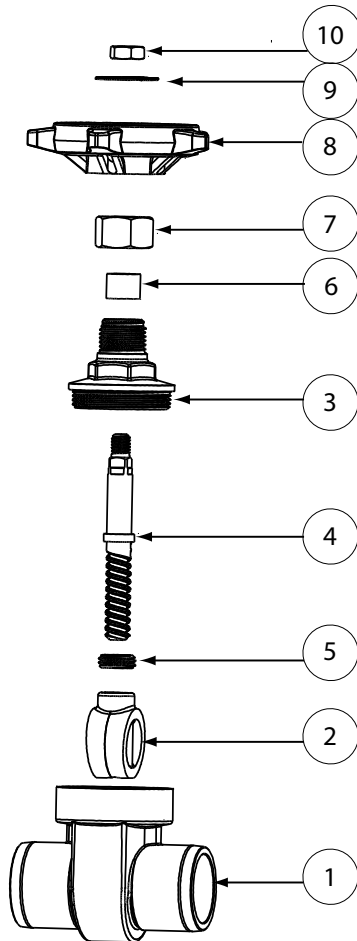

Materials of Construction

No.	Description	Material	Specification
1	Body	Low Lead Brass	CW510L
2	Wedge	Low Lead Brass	CW510L
3	Bonnet	Low Lead Brass	CW510L
4	Stem	Low Lead Brass	CW510L
5	Ring	Low Lead Brass	CW510L
6	Packing Ring	Graphite	WRAS Approved
7	Packing Nut	Brass	BS2874 CZ122
8	Handwheel	Aluminum	B85 Red Painted
9	Disc	Aluminum	B85
10	Nut	Zinc Plated Steel	A36

Industry Standards

Meet the requirements of California's AB1953 and in full compliance with NSF61 Annex G.

Dimensions and Weights

Inches (millimeters) - Pounds (kilograms)

Valve Size	Dimensions					Wt.	Cv
	A	C	H	L	P		
1/2	1.97	0.65	2.79	2.51	0.51	0.53	10.8
	(50)	(17)	(71)	(64)	(13)	(0.24)	
3/4	2.12	0.65	3.17	2.51	0.74	0.82	23
	(54)	(17)	(81)	(64)	(19)	(0.37)	
1	2.44	0.78	3.93	2.99	1.00	1.17	42
	(62)	(20)	(100)	(76)	(25)	(0.53)	
1 1/4	2.75	0.86	4.37	3.54	1.25	1.83	72
	(70)	(22)	(111)	(90)	(32)	(0.83)	
1 1/2	2.84	0.86	4.94	3.54	1.50	2.38	120
	(72)	(22)	(125)	(90)	(38)	(1.08)	
2	3.23	0.86	6.27	4.13	2.00	4.03	210
	(82)	(22)	(159)	(105)	(51)	(1.82)	

Low Lead Swing Check Valve Figure LFB-309Y 200 CWP • Y-Pattern • Bronze Disc • Solder Ends

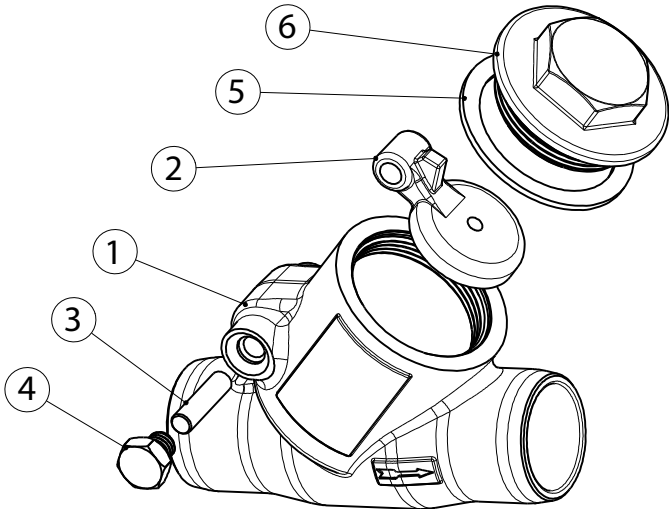

Materials of Construction

No.	Description	Material
1	Body	AB1953 Brass 0T60
2	Retaining Disc	AB1953 Brass 0T57
3	Stem	AB1953 Brass 0T57
4	Screw	AB1953 Brass 0T57
5	Gasket	PTFE AE/2
6	Cap	AB1953 Brass 0T57

Industry Standards

Meet the requirements of California's AB1953 and in full compliance with NSF61 Annex G.

See page 7 for Pressure-Temperature Ratings

Dimensions and Weights

Inches (millimeters) - Pounds (kilograms)

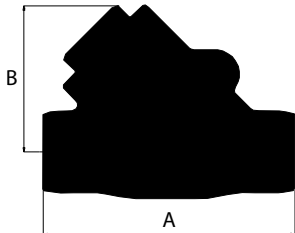

Valve Size	Dimensions		Wt.
	A	B	
1/2	2.60	1.65	0.35
	(66)	(42)	(0.16)
3/4	3.39	1.97	0.87
	(86)	(50)	(0.40)
1	4.09	2.28	1.33
	(104)	(58)	(0.60)
1 1/4	4.72	2.71	2.04
	(120)	(69)	(0.93)
1 1/2	5.35	3.19	2.80
	(136)	(81)	(1.27)
2	6.69	3.86	4.78
	(170)	(98)	(2.16)

Low Lead Swing Check Valve Figure LFB-319Y

Class 125 • Y-Pattern • Bronze Disc • Threaded Ends

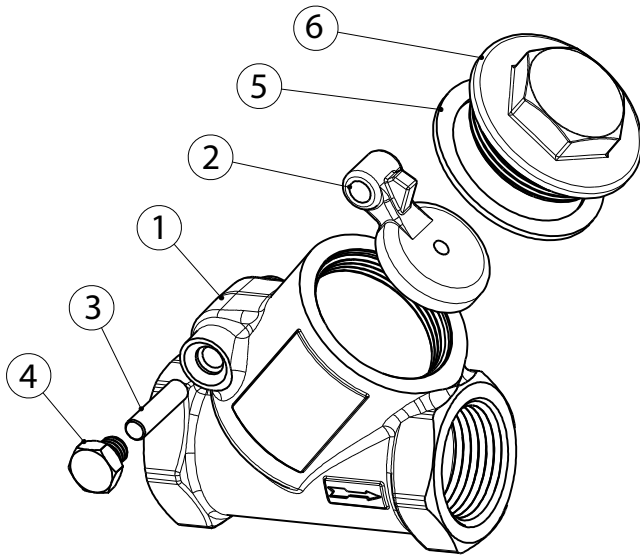

Materials of Construction

No.	Description	Material
1	Body	AB1953 Brass OT60
2	Retaining Disc	AB1953 Brass OT57
3	Stem	AB1953 Brass OT57
4	Screw	AB1953 Brass OT57
5	Gasket	PTFE AE/2
6	Cap	AB1953 Brass OT57

Industry Standards

Meet the requirements of California's AB1953 and in full compliance with NSF61 Annex G.

See page 7 for Pressure-Temperature Ratings

Dimensions and Weights

Inches (millimeters) - Pounds (kilograms)



Valve Size	Dimensions		Wt.
	A	B	
½	2.21	1.65	0.58
	(56)	(42)	(0.26)
¾	2.76	1.97	0.93
	(70)	(50)	(0.42)
1	3.15	2.28	1.37
	(80)	(58)	(0.62)
1¼	3.78	2.71	2.15
	(96)	(69)	(0.98)
1½	4.33	3.19	2.97
	(110)	(81)	(1.35)
2	5.04	3.86	4.82
	(128)	(98)	(2.18)



CRANE

Energy Flow Solutions



brands you trust.



COMPAC-NOZ

CRANE

DUO-CHEK



NOZ-CHEK



STOCKHAM



UNI-CHEK

VALVE SERVICES



Potravinářský průmysl
Farmaceutický průmysl
Biotechnologie
Petrochemie
Chemický průmysl
Energetika
Úprava vody
Papírenství a zpracování celulózy
Plynárenský průmysl
Keramický průmysl
Zpracovatelský průmysl



Firma s tradicí od r. 1990 se při svém vzniku zaměřila na dodávky základních komponent, přístrojové a měřicí techniky a dodávky technologií pro farmaceutický a potravinářský průmysl. Cílem bylo zajistit kompletní dodavatelsko - inženýrské služby, včetně servisu. V roce 1998, který byl pro firmu velmi významným mezníkem, proběhla transformace společnosti do nynější formy. V dalších letech činnosti společnosti dochází k rozšíření portfolia a je navazována spolupráce s partnery v oblasti armatur, komponent, ventilů, procesní měřicí techniky a čerpadel.

Oblastí působnosti je potravinářský, farmaceutický průmysl, biotechnologie, chemický průmysl, petrochemie, úprava vody, papírenství a celulóza, energetika, keramický průmysl a zpracovatelský průmysl.

Firma REGOM INSTRUMENTS je díky širokému dodavatelskému portfoliu a bohatým zkušenostem schopna zajistit dodávky armatur, komponent, čerpadel, přístrojů a zařízení.

Cílem společnosti REGOM INSTRUMENTS je poskytování kvalitních služeb a spolehlivých dodávek pro co nejširší okruh zákazníků.



REGOM INSTRUMENTS s.r.o.

Brabcova 1159 / 2

147 00 Praha 4

CZECH REPUBLIC

Tel: +420 241 402 206

Fax: +420 241 400 290

Mail: regom@regom.cz

Skype: regom-office

www.regom.cz