

Sight Flow Indicators (straight line) with *pipe - socket weld* connection

regom
instruments

Bauform 880-SOW

Application:

The flow indicators are used for optical control of fluids and gases, for horizontal and vertical pipe-lines. Also available with internal spinner or flap.

Operating conditions:

Working pressure: 16 / 25 / 40 bar

Working temperature: 150°C or 280°C

Installation:

Optional. Take care of flow direction

Options:

with Rotor or Flap

with Sight glass light - fittings

Materials:

Cast Steel GS-C 25 (1.0619 / GP240GH)

Stainless Steel WN 1.4408

Body	GS-C 25	1.4408
Covers	GS-C 25	1.4408
Screws	4.6 / 5.6 gal.	A4-70
Glass	Borosilicate glass DIN 7080 Soda-lime glass DIN 8902	
Gaskets	Graphite, (or other materials)	

Certificate: (Option)

Acc. to EN 10204 - 2.2 or 3.1

Ordering example:

Sight Flow Indicators with socket weld ends

Bauform 880-SOW

Body GS-C 25, Borosilicate glass DIN 7080 - 16 bar

DN20 (3/4") / Ø 27.5

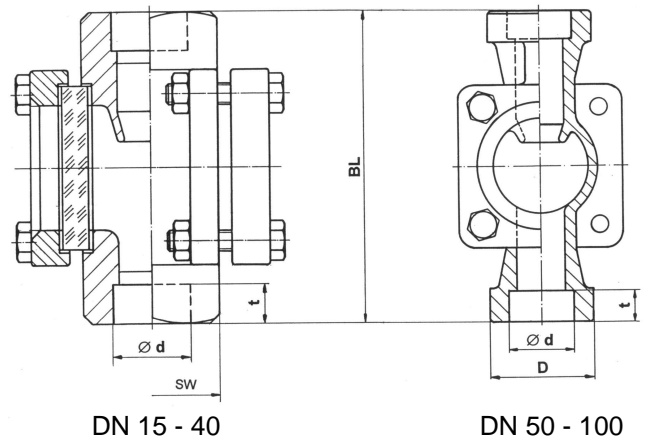

Dimensions:

nom. size DN / SW	D	BL	Ø d	t
15 (1/2")	SW 36	100	22	10
20 (3/4")	SW 36	100	27,5	10
25 (1")	SW 46	120	34,5	13
32 (1 1/4")	SW 75	160	43	13
40 (1 1/2")	SW 75	160	49	13
50 (2")	Ø 75	230	61,5	16
80 (3")	Ø 120	310	90	16
100 (4")	Ø 150	350	115,5	20

Modification reserved

REGOM INSTRUMENTS s.r.o.
Brabcova 1159 / 2
147 00 Praha 4
CZECH REPUBLIC

Tel: +420 241 402 206
Fax: +420 241 400 290
Mail: regom@regom.cz
Skype: regom-office
www.regom.cz

regom
instruments