

# High pressure Sight Glass Indicator

**regom**  
instruments

Bauform 912

## Application:

The flow indicators are used for optical control of fluids and gases, for horizontal and vertical pipe lines.

## Operating conditions:

Working pressure: up to 160 bar  
Working temperature: with borosilicate glass max. 280°C  
with quartzglass up to 500°C

## Installation:

Optional

## Possible Connection:

Flange connection acc. to DIN up to PN 160  
Flange connection acc. to ANSI up to 1.500 LBS  
Butt weld ends  
Female-threaded

## Dimensions:

Working pressure and nominal diameter have an affect on the length.

## Options:

with - ANSI-flanges  
- Butt weld ends  
- Heating jacket  
- Sight glass light - fittings

## Materials:

All materials which can be welded are possible.

## Certificate: ( Option )

Acc. to EN 10204 - 2.2 or  
Acc. to EN 10204-3.1

High pressure -  
design

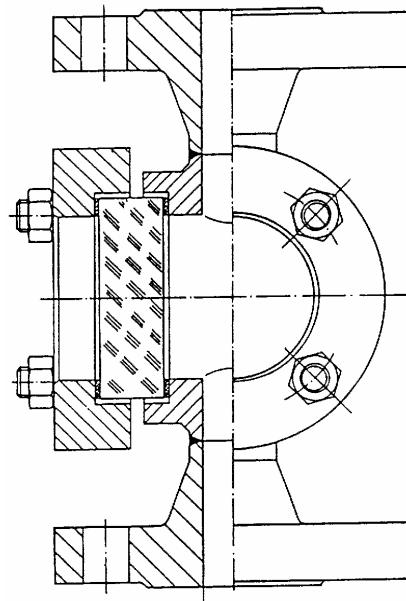

Modification reserved

REGOM INSTRUMENTS s.r.o.  
Brabčova 1159 / 2  
147 00 Praha 4  
CZECH REPUBLIC

Tel: +420 241 402 206  
Fax: +420 241 400 290  
Mail: [regom@regom.cz](mailto:regom@regom.cz)  
Skype: regom-office

[www.regom.cz](http://www.regom.cz)

**regom**  
instruments