

## REGOM INSTRUMENTS s.r.o.

Brabcova 1159 / 2  
147 00 Praha 4  
CZECH REPUBLIC

Tel: +420 241 402 206  
Fax: +420 241 400 290  
Mail: [regom@regom.cz](mailto:regom@regom.cz)  
Skype: regom-office

[www.regom.cz](http://www.regom.cz)



## Technische Daten

### BAUFORM

1-teilige Körperkonstruktion, mit PTFE-Manschette zweiteiliges Gehäuse, mit auswechselbarer Manschette. Zum Einklemmen zwischen zwei Flansche nach **EN 1092-1 Typ 11 Form B (PN10/PN16)** oder als Abschlussarmatur (Mittelflanschführung).  
Ab DN 50 Baulänge nach EN 558-1 Reihe 20.

Auch lieferbar mit Zulassung für Gase nach DIN-DVGW / G.

### BETÄTIGUNG

90°-Drehung des Handhebels, mit 10 Einrastmöglichkeiten. Ab DN 350 mit Getriebe.

### ANSCHLUß

Flansch DN40 ... DN400  
PN 10, PN 16, ANSI 150  
Größere Nennweiten auf Anfrage.

### BETRIEBSDRUCK

Großvakuum von 970 mbar<sub>(abs)</sub> bis:

#### zwischen 2 Flanschen:

- max. 16 bar
- Aluminium-Gehäuse max. 10 bar
- PTFE-Manschette max. 6 bar (10 bar)

#### als Endklappe:

max. 6bar

### MEDIUMTEMPERATUR

PTFE = -60°C ... +190°C\*  
NBR = -25°C ... +100°C\*  
EPDM = -35°C ... +130°C\*  
FKM = -20°C ... +200°C  
Neopren = -20°C ... +100°C  
Silikon = -60°C ... +190°C\*

\*: in Kombination mit einem Gehäuse aus GGG-40: t<sub>min</sub> = -20°C

### WERKSTOFFE

Gehäuse:  
• Sphäroguß GGG-40  
• Edelstahl 1.4408  
• Aluminium-Legierung

Scheibe:  
• Edelstahl 1.4408  
• DN50...DN100: Stahl, verzinkt  
DN125...DN300: GS400, verzinkt  
• PTFE- beschichtet

Wellendichtung: NBR (FKM auf Anfrage)  
Welle: Edelstahl 1.4016  
Buchse: Bronze  
Manschette:  
• PTFE  
• NBR  
• FKM  
• EPDM  
• Neoprene  
• Silikon

Handhebel: Aluminium Druckguss

### ZUSATZAUSSTATTUNG

Polierte Klappenscheibe, pneumatischer oder elektrischer Schwenkantrieb, Stellungsanzeige mit elektrisch/mechanischen oder induktiven Endschaltern.

Alle Angaben sind freibleibend und unverbindlich!

## Specification

### DESIGN

Body consists of 1 part, with PTFE-seat body consists of 2 parts, with exchangeable seat. To be mounted between two flanges acc. to **EN 1092-1 Typ 11 Form B (PN10/PN16)** or end piping mounting (LUG-type)  
From DN 50 face to face dimension acc. to EN 558-1 R20.

Also available with permission for gases according to DIN-DVGW / G.

### OPERATION

Rotation of the handle through 90°, with 10 snap-in positions. From DN 350 with gear box.

### CONNECTION

Flange DN40 ... DN400  
PN 10, PN 16, ANSI 150  
Bigger sizes on request.

### PRESSURE RANGE

Vacuum about 970 mbar<sub>(abs)</sub> up to:

#### between 2 flanges:

- max. 16 bar
- Aluminium body max. 10 bar
- PTFE-Seat max. 6 bar (10 bar)

#### dead end service:

max. 6bar

### TEMPERATURE RANGE

PTFE = -60°C ... +190°C\*  
NBR = -25°C ... +100°C\*  
EPDM = -35°C ... +130°C\*  
FKM = -20°C ... +200°C  
Neopren = -20°C ... +100°C  
Silikon = -60°C ... +190°C\*

\*: in combination with body material GGG-40: t<sub>min</sub> = -20°C

### MATERIALS

Body:  
• Ductile iron GGG-40  
• Stainless steel AISI 316  
• Aluminium-alloy

Disc:  
• Stainless steel 1.4408  
• DN50...DN100: Steel, zinc-plated  
DN125...DN300: GS400, zinc-plated  
• PTFE- coated

Shaft seal: NBR (FKM on request)  
Shaft: Stainless Steel 1.4016  
Bearing shell: Bronze  
Seat:  
• PTFE  
• NBR  
• FKM  
• EPDM  
• Neoprene  
• Silicone

Handle: Aluminium alloy

### OPTIONS

Polished disc, pneumatic or electric actuator, electric position indicator with electric/mechanic or inductive proximity switches.

The above information is intended for guidance only and the company reserves the right to change any data herein without prior notice!

Artikel:

**TA / TM**

Absperrklappe

PN10, PN16, ANSI 150

Sphäroguss (GGG-40)

Edelstahl

Aluminium



Type:

**TA / TM**

Butterfly valve

PN10, PN16, ANSI 150

Ductile iron (GGG-40)

Stainless steel

Aluminium

auch lieferbar mit  
Zulassung nach: /  
also available with  
permission acc. to:



**Artikel- u. Bestellangaben:** z.B. TA534010

= Absperrklappe, GGG-40, Edelstahl, EPDM, DN 100

1.+ 2. Stelle Produkt	3. Stelle Gehäusewerkstoff	4. Stelle Scheibenwerkstoff	5. Stelle Manschettenwerkstoff	6. Stelle Zusatzausstattung	7.+ 8. Stelle Anschlußgröße
<b>TA</b> = Absperrklappe, voller Durchgang.	<b>3</b> = Edelstahl 1.4408 <b>5</b> = GGG-40 <b>6</b> = Aluminium- Legierung	<b>1</b> = Scheibe PTFE- beschichtet <b>3</b> = Edelstahl 1.4408 <b>5</b> = DN50...DN100: Stahl verzinkt, DN125...DN300: GS400 verzinkt, ab DN350: GGG-40	<b>1</b> = PTFE <b>2</b> = NBR <b>3</b> = FKM <b>4</b> = EPDM <b>5</b> = Neoprene <b>6</b> = Silikon	<b>0</b> = ohne <b>1</b> = PTFE- Manschette PN 10 <b>6</b> = DIN - DVGW/G Zulassung	<b>06</b> = DN 40 <b>07</b> = DN 50 <b>08</b> = DN 65 <b>09</b> = DN 80 <b>10</b> = DN 100 <b>11</b> = DN 125 <b>12</b> = DN 150 <b>13</b> = DN 200 <b>14</b> = DN 250 <b>15</b> = DN 300 Größere Nennweiten auf Anfrage

**Ordering example:** e.g. TA534010

= Butterfly valve, GGG-40, Stainless steel, EPDM, DN 100

1.+ 2. Digit Product	3. Digit Body material	4. Digit Disc material	5. Digit Seat material	6. Digit Options	7.+ 8. Digit Connection size
<b>TA</b> = Butterfly valve, full bore.	<b>3</b> = Stainless steel AISI 316 <b>5</b> = GGG-40 <b>6</b> = Aluminium- alloy	<b>1</b> = disc PTFE - coated <b>3</b> = Stainless steel 1.4408 <b>5</b> = DN50...DN100: Steel zinc-plated, DN125...DN300: GS400 zinc-plated, from DN350: GGG-40	<b>1</b> = PTFE <b>2</b> = NBR <b>3</b> = FKM <b>4</b> = EPDM <b>5</b> = Neoprene <b>6</b> = Silicone	<b>0</b> = no options <b>1</b> = PTFE- seat PN 10 <b>6</b> = DIN - DVGW/G permission	<b>06</b> = DN 40 <b>07</b> = DN 50 <b>08</b> = DN 65 <b>09</b> = DN 80 <b>10</b> = DN 100 <b>11</b> = DN 125 <b>12</b> = DN 150 <b>13</b> = DN 200 <b>14</b> = DN 250 <b>15</b> = DN 300 Bigger sizes on request

**Stückliste / Parts list**

Pos.	Bezeichnung / Description		Material / Material	
1	Gehäuse	Body	• Sphäroguß GGG-40 • Edelstahl 1.4408 • Aluminium Legierung	• Ductile iron GGG-40 • Stainless steel AISI 316 • Aluminium alloy
2	Scheibe	Disc	• Edelstahl 1.4408 • DN50...DN100: Stahl verzinkt, DN125...DN300: GS400 verzinkt, ab DN350: GGG-40 • PTFE- beschichtet	• Stainless steel 1.4408 • DN50...DN100: Steel zinc-plated, DN125...DN300: GS400 zinc-plated, from DN350: GGG-40 • PTFE- coated
3	Manschette	Seat	• PTFE • NBR • FKM • EPDM • Neoprene • Silikon	• PTFE • NBR • FKM • EPDM • Neoprene • Silicone
4	Untere Spindel	Lower stem	Edelstahl 1.4016 (1.4401 auf Anfrage)	Stainless steel 1.4016 (1.4401 on request)
5	Obere Spindel	Upper stem	Edelstahl 1.4016 (1.4401 auf Anfrage)	Stainless steel 1.4016 (1.4401 on request)
6	Buchse	Bush	Bronze	Bronze
7	Spindeldichtung	Stem seals	NBR (FKM auf Anfrage)	NBR (FKM on request)
8	Verschlußdichtung	Plug seals	Aluminium	Aluminium
9	6-kt. Stopfen	Hexagon plug	Stahl verzinkt	Steel zinc-plated
10	Verschlußscheibe	Bush disc	Aluminium, ab DN 350 = Stahl verzinkt	Aluminium, from DN 350 = steel zinc-plated
11	Schraube	Screw	Stahl verzinkt	Steel zinc-plated
12	Segerring	Stop ring	Stahl	Steel
13	Buchse	Bush	Bronze	Bronze
14	Verschlußscheibe	Bush disc	Stahl verzinkt	Steel zinc-plated
15	Verschlußdichtung	Bush seals	NBR	NBR
16	Schraube	Screw	Stahl verzinkt	Steel zinc-plated
17	Buchse	Bush	Bronze, ab DN 450 = Stahl + PTFE	Bronze, from DN 450 = steel + PTFE
18	O-Ring	O-ring	NBR	NBR
19	O-Ring	O-ring	NBR	NBR
20	Paßfeder	Key	Stahl C 40	Steel C 40

**Positionen / Positions DN 40 - DN 300**

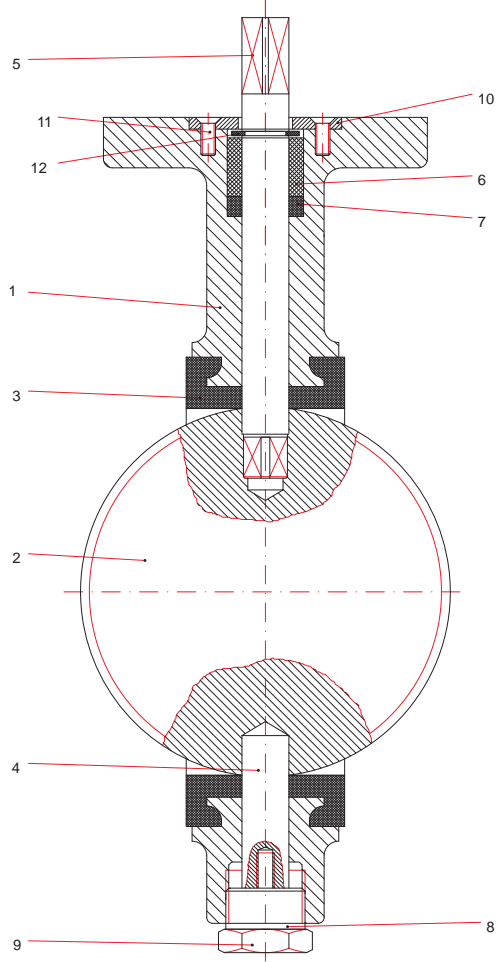

**Positionen / Positions DN 350 - DN 500**

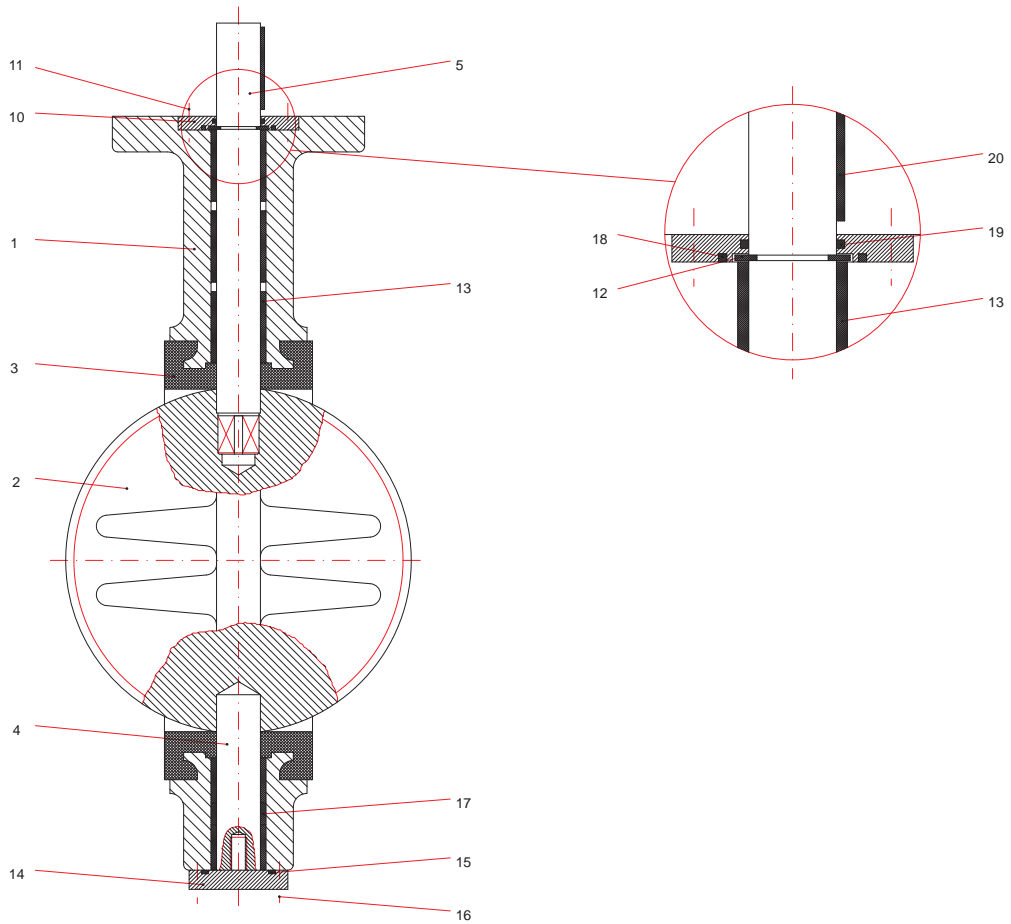

# Abmessungen Standardausführung / Dimension standard type

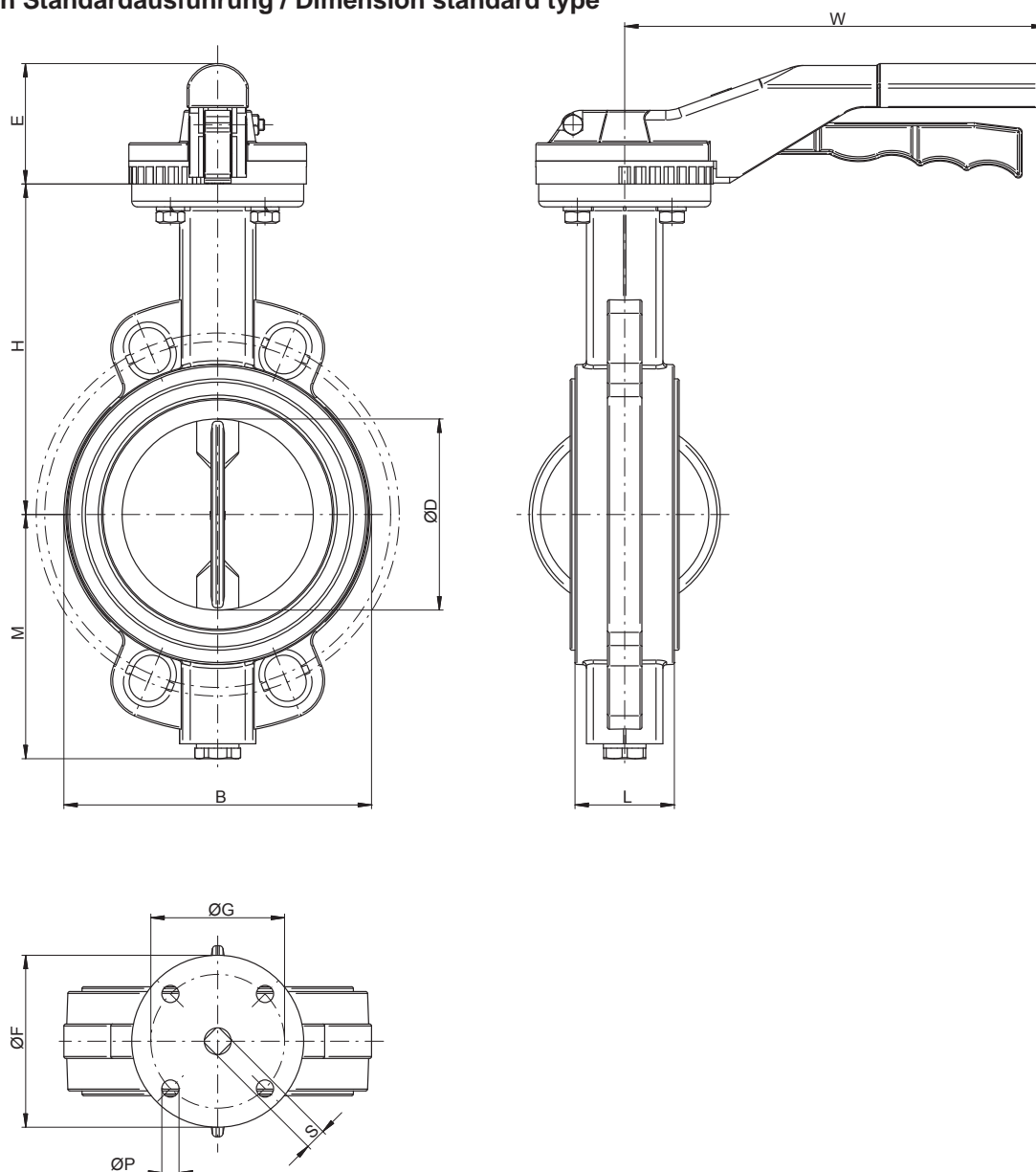

DN	H	M	B	D	L	F	G	P	E	W	S	kg [1]	kg [2]
40	130	75	84	49	33	90	70	9	40	265	11	2,2	1,4
50	138	81	102	55	43	90	70	9	40	265	11	3,0	1,5
65	148	89	116	68	46	90	70	9	40	265	11	3,5	1,8
80	158	110	133	81	46	90	70	9	40	265	11	4,0	1,9
100	173	128	160	101	52	90	70	9	40	265	11	6,0	3,1
125	186	140	190	126	56	90	70	9	40	265	14	7,2	3,6
150	202	155	214	150	56	90	70	9	40	265	14	9,5	5,7
200	240	190	265	200	60	125	102	11	47	350	17	18	9,7
250	270	220	320	250	68	125	102	11	47	350	22	25	14,0
300	300	247	373	298	78	125	102	11	47	350	22	35	18,3
350	330	280	425	341	78	150	125	14	-	-	-	64	
400	355	305	490	390	102	150	125	14	-	-	-	80	
450	400	343	535	444	114	175	140	18	-	-	-	110	
500	422	366	590	495	127	210	165	22	-	-	-	140	
600	495	460	692	595	154	210	165	22	-	-	-	220	
700	550	506	804	690	165	300	254	18	-	-	-	300	
800	640	590	905	780	190	300	254	18	-	-	-	465	

[1] = Gehäuse aus Stahl / body made of steel  
 [2] = Gehäuse aus Aluminium / body made of aluminium

Abmessungen für Absperrklappe mit PTFE- Dichtung / Demension for butterfly valve with PTFE- sealing :

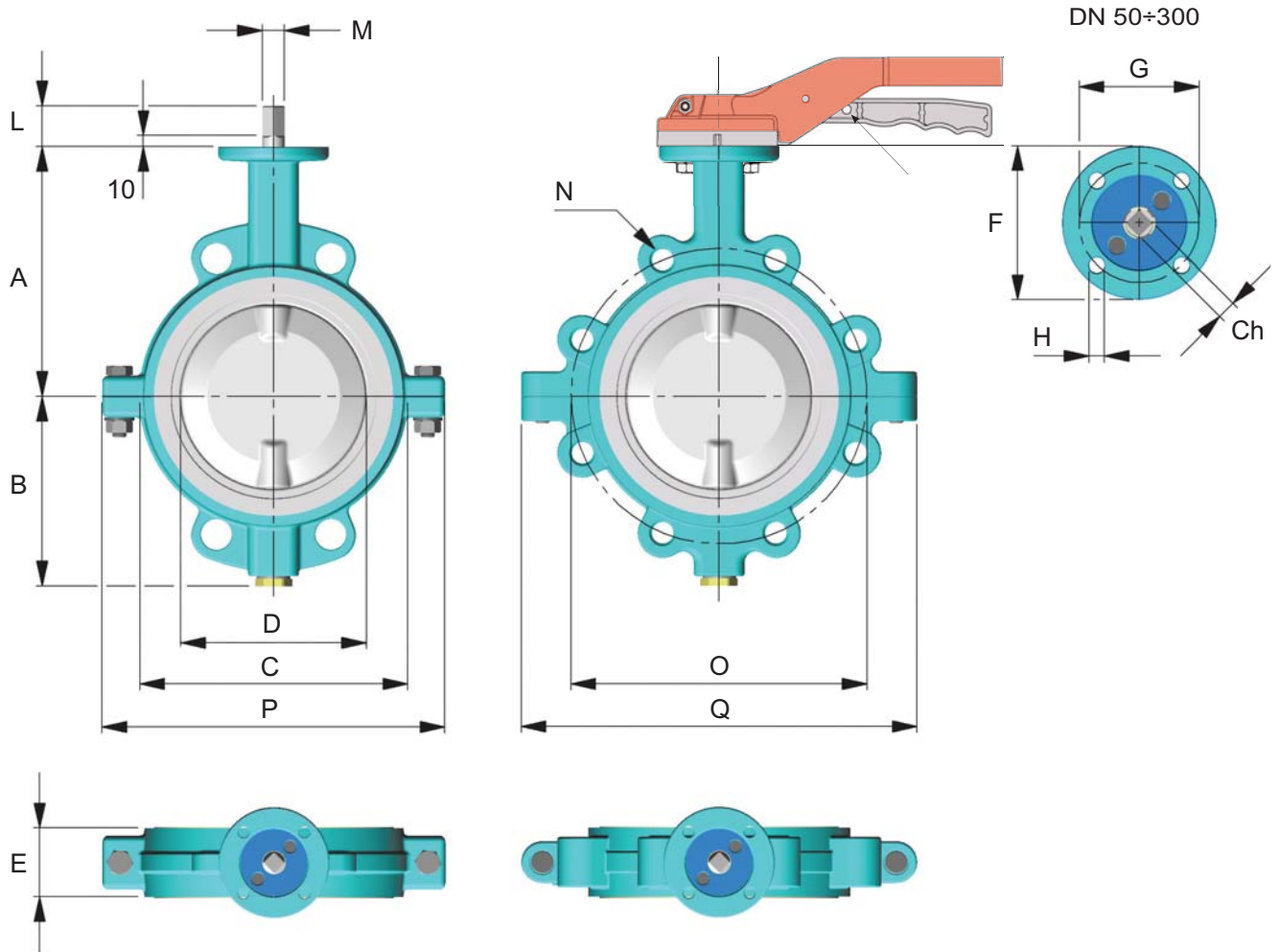

**Aufbau der PTFE- Dichtung / Construction of the PTFE- sealing**

PTFE min. Wandstärke = 2,5 mm /  
PTFE min. wall thickness = 2,5 mm

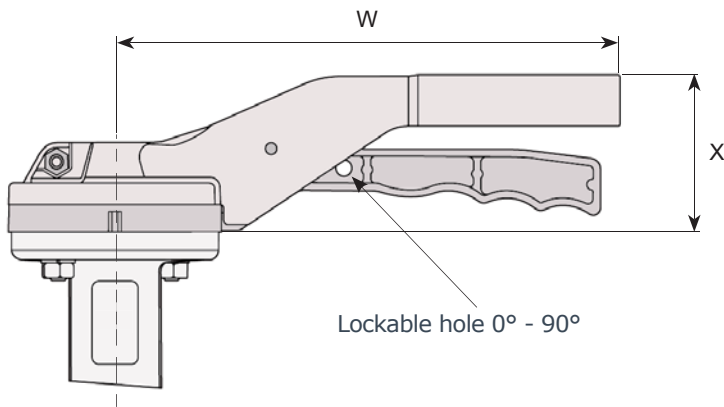

**Silikon**  
Temperatur max. +200°C/  
**Silicon**  
Temperature max. +200°C

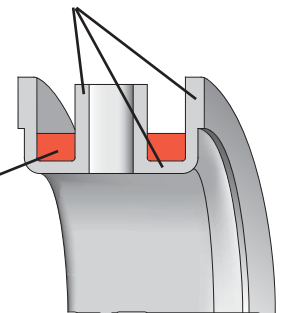

DN	A	B	D	C	E	F	G	H	L	Ch	ØM	P	Q	PN 10			PN 16			X	W
														N	n.	B	N	n.*	B		
50	138	81	55	102	43	90	70	9	34	11	14	165	165	M16	4	125	M16	4	125	67	93
65	148	89	68	116	46	90	70	9	34	11	14	186	186	M16	4	145	M16	4	145	67	93
80	158	110	81	133	46	90	70	9	34	11	14	196	242	M16	8	160	M16	8	160	67	93
100	173	128	101	160	52	90	70	9	34	11	16	220	270	M16	8	180	M16	8	180	67	93
125	186	140	126	190	56	90	70	9	34	14	18	250	297	M16	8	210	M16	8	210	67	93
150	202	155	150	214	56	90	70	9	34	14	18	278	321	M20	8	240	M20	8	240	67	93
200	240	190	200	265	60	125	102	11	38	17	22	355	420	M20	8	295	M20	12	295	76	125
250	270	220	250	320	68	125	102	11	38	22	30	398	472	M20	12	350	M24	12	355	76	125
300	300	247	298	373	78	125	102	11	38	22	30	455	540	M20	12	400	M24	12	410	76	125

**Abmessungen Mittelflansch Ausführung / Dimension LUG-type  
PN 10, PN 16, ANSI 150**

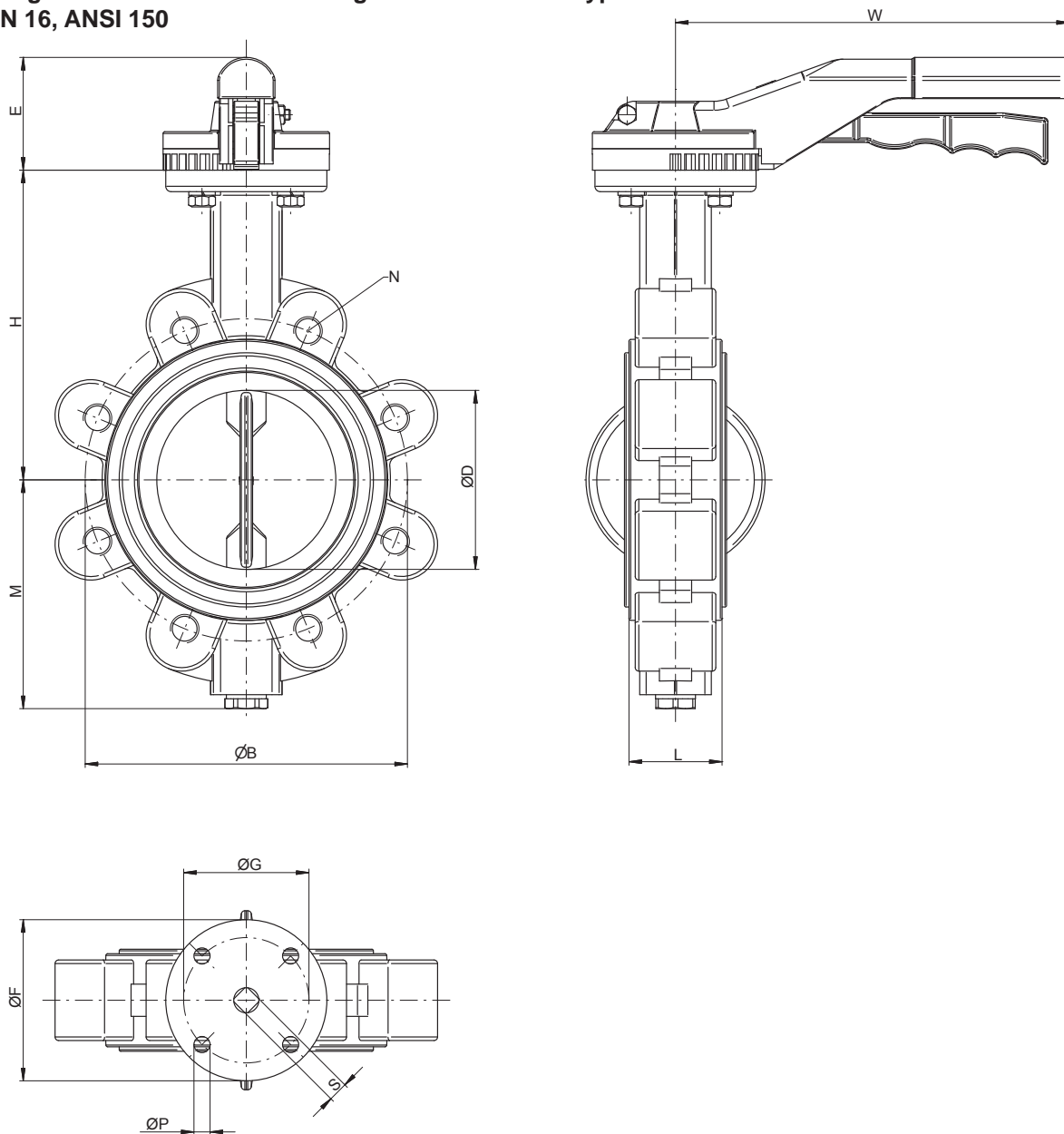

DN	H	M	D	L	F	G	P	E	S	N	PN 10		PN 16		ANSI 150			kg	
											n.	B	N	n.*	B	N	n.		B
40	130	75	49	33	90	70	9	40	11	M16	4	110	M16	4	110	M14	4	98,4	3,1
50	138	81	55	43	90	70	9	40	11	M16	4	125	M16	4	125	M16	4	10,6	4,2
65*	148	89	68	46	90	70	9	40	11	M16	4	145	M16	4	145	M16	4	139,7	4,9
80	158	110	81	46	90	70	9	40	11	M16	8	160	M16	8	160	M16	4	152,4	7,2
100	173	128	101	52	90	70	9	40	11	M16	8	180	M16	8	180	M16	8	190,5	8,2
125	186	140	126	56	90	70	9	40	14	M16	8	210	M16	8	210	M20	8	215,9	10,5
150	202	155	150	56	90	70	9	40	14	M20	8	240	M20	8	240	M20	8	241,3	11,8
200	240	190	200	60	125	102	11	47	17	M20	8	295	M20	12	295	M20	8	298,4	24,9
250	270	220	250	68	125	102	11	47	22	M20	12	350	M24	12	355	M22	12	361,9	33,9
300	300	247	298	78	125	102	11	47	22	M20	12	400	M24	12	410	M22	12	431,8	48,9
400	355	305	390	102	150	125	14	-	12	M24	16	515	M27	16	525	M27	16	539,7	90
500	422	366	495	127	210	165	22	-	12	M24	20	620	M30	20	650	M27	20	635	180
600	495	460	595	154	210	165	22	-	18	M27	20	725	M33	20	770	M33	20	749,3	290
700	550	506	690	165	300	254	18	-	20	M27	24	840	M33	24	840	M33	28	863,5	415
800	640	590	780	190	300	254	18	-	22	M30	24	950	M33	24	950	M33	28	977,9	570

\*) Flansche PN16 - DN65 werden in 4-Loch-Ausführung geliefert! / Flanges PN16 - DN65 will be delivered in 4-hole execution!

**Abmessungen Mittelflansch Ausführung / Dimension LUG-type  
PN 25**

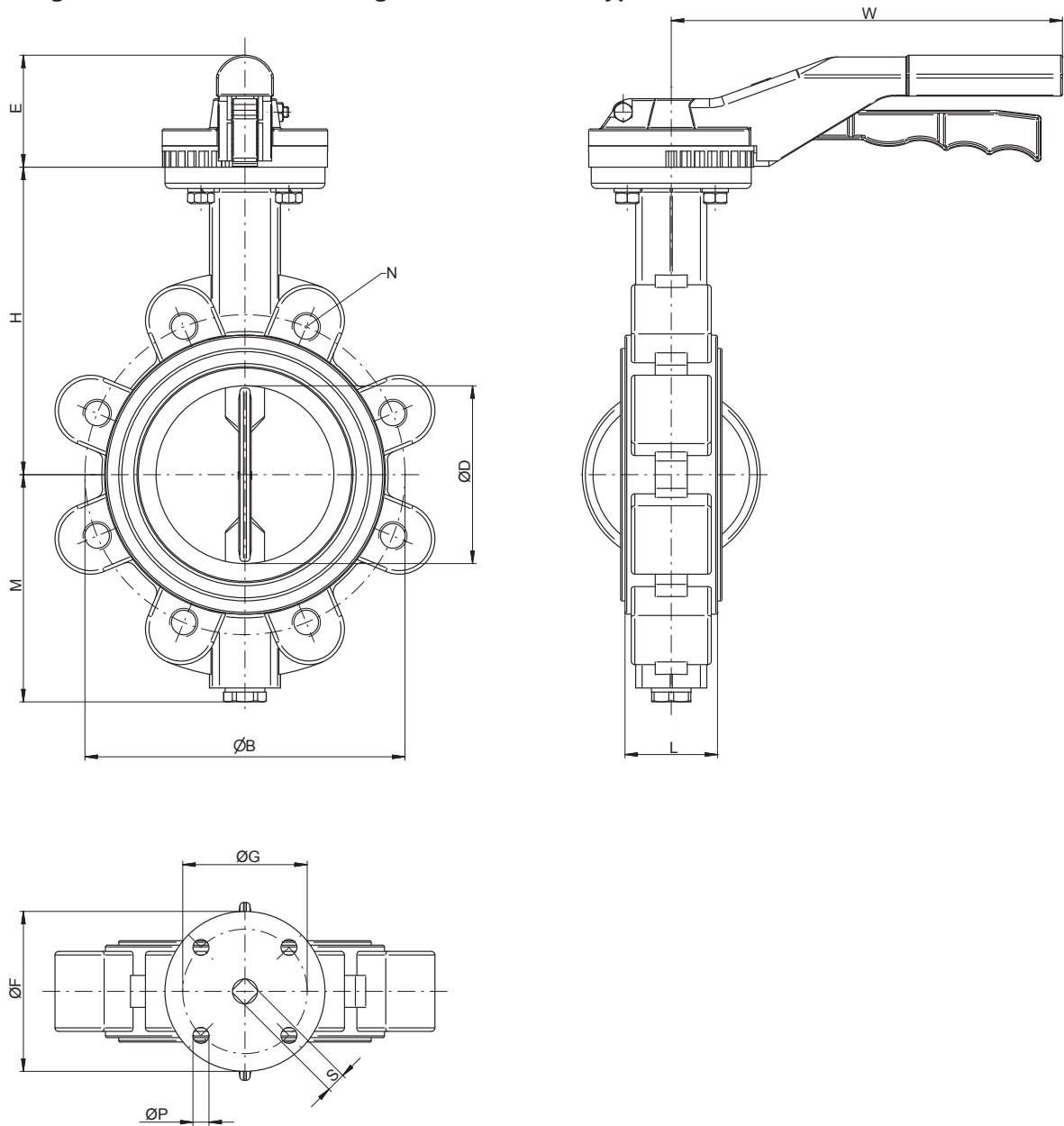

DN	H	M	D	L	F	G	P	E	S	N	PN 25		kg
											n.	B	
50	138	81	55	43	90	70	9	34	11	M16	4	125	4,2
80	158	110	81	46	90	70	9	34	11	M16	8	160	7,2
100	173	128	101	52	90	70	9	34	11	M20	8	190	8,2
125	186	140	126	56	90	70	9	34	14	M24	8	220	10,5
150	202	155	150	56	90	70	9	34	14	M24	8	250	11,8
200	240	190	200	60	125	102	11	38	17	M24	12	310	24,9

## Abmessungen Absperrklappe mit Getriebe / Dimension butterfly valve with gear box

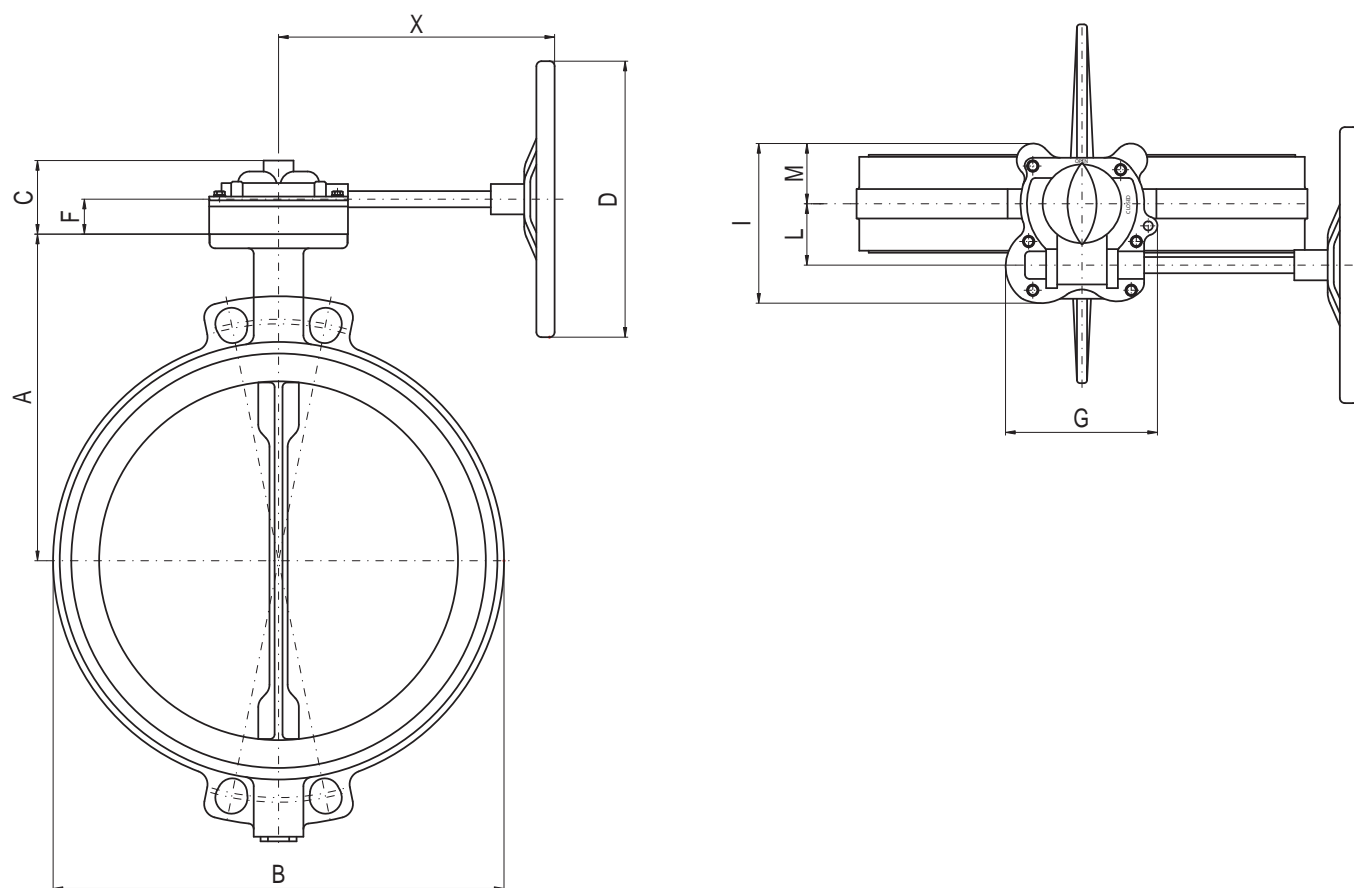

DN	B	X	A	C	D	F	G	I	L	M
40	84	140	130	55	125	27	96	107	39	46
50	102	140	138	55	125	27	96	107	39	46
65	116	140	148	55	125	27	96	107	39	46
80	133	140	158	55	125	27	96	107	39	46
100	160	140	173	55	125	27	96	107	39	46
125	190	140	186	55	125	27	96	107	39	46
150	214	140	202	55	125	27	96	107	39	46
200	265	180	240	60	200	29	122	132	47	56
250	320	205	270	60	200	29	137	150	60	62
300	373	205	300	60	200	29	137	150	60	62
350	425	240	330	69	250	33	175	190	76	79
400	490	300	355	80	300	38	165	175	66,7	65,5
500	590	245	422	93,5	350	50	198	220	89,5	86
600	692	335	495	105,5	400	50	252	295	123	114
700	804	360	550	127	500	50	315	300	154	117
800	905	430	640	128	600	66	310	300	138	155

### Hinweis

Bei den in dieser Dokumentation beschriebenen Produkten, in der von uns gelieferten Form, handelt es sich weder um Maschinen gemäß Artikel 2 Absatz a noch um unvollständige Maschinen gemäß Artikel 2 Absatz g im Sinne der Richtlinie 2006/42/EG über Maschinen.

### Advice

The products described in this documentation in the conditions of our delivery are no machinery according to annex 2 paragraph a respectively no partly completed machinery according to annex 2 paragraph g of the directive 2006/42/EC on machinery.



## Durchflusswerte / Flow rate

### Formeln zur Berechnung der Durchflussmenge / Formula for calculation of flow rate

#### Flüssigkeiten / Liquids

$$Q = \frac{Kv}{\sqrt{\frac{P_s}{\Delta P}}}$$

Q = Durchflussmenge / flow rate [m³/h]  
 P<sub>s</sub> = Dichte / specific gravity (Wasser / water = 1) [kg/dm³]  
 ΔP = Druckdifferenz / pressure drop [bar]

#### Gase / Gases

$$Q = 28,5 \cdot \frac{Kv}{\sqrt{P_2 \cdot \Delta P}}$$

Q = Durchflussmenge / flow rate [m³/h]  
 P<sub>s</sub> = Dichte / specific gravity (Wasser / water = 1) [kg/dm³]  
 ΔP = Druckdifferenz / pressure drop [bar]  
 (kleiner ½ · Eingangsdruck / less than ½ · inlet pressure)  
 P<sub>2</sub> = Ausgangsdruck / outlet pressure [bar]

#### Dampf / Steam

$$Q = 22,5 \cdot Kv \cdot \sqrt{P_2 \cdot \Delta P}$$

Q = Durchflussmenge / flow rate [m³/h]  
 ΔP = Druckdifferenz / pressure drop [bar]  
 (kleiner ½ · Eingangsdruck / less than ½ · inlet pressure)  
 P<sub>2</sub> = Ausgangsdruck / outlet pressure [bar]

### Formeln zur Berechnung der Durchflussmenge äquivalent zu H<sub>2</sub>O / Formula for calculation of flow rate equivalent to H<sub>2</sub>O

$$Q_E = Q \cdot \sqrt{\frac{d}{1000}}$$

Bei andere Flüssigkeiten, Gasen oder Dampf als Wasser muss der Druckverlust mit dieser Formel auf eine äquivalenten Wert gebracht werden / for different liquids, gases or steam head loss are determined by equivalent water flow rate:

Q<sub>E</sub> = äquivalente Durchflussmenge Wasser / equivalent flow rate water [m³/h] oder [l/s]  
 Q = Durchflussmenge / flow rate [m³/h] oder [l/s]  
 d = Dichte / specific gravity [kg/dm³]

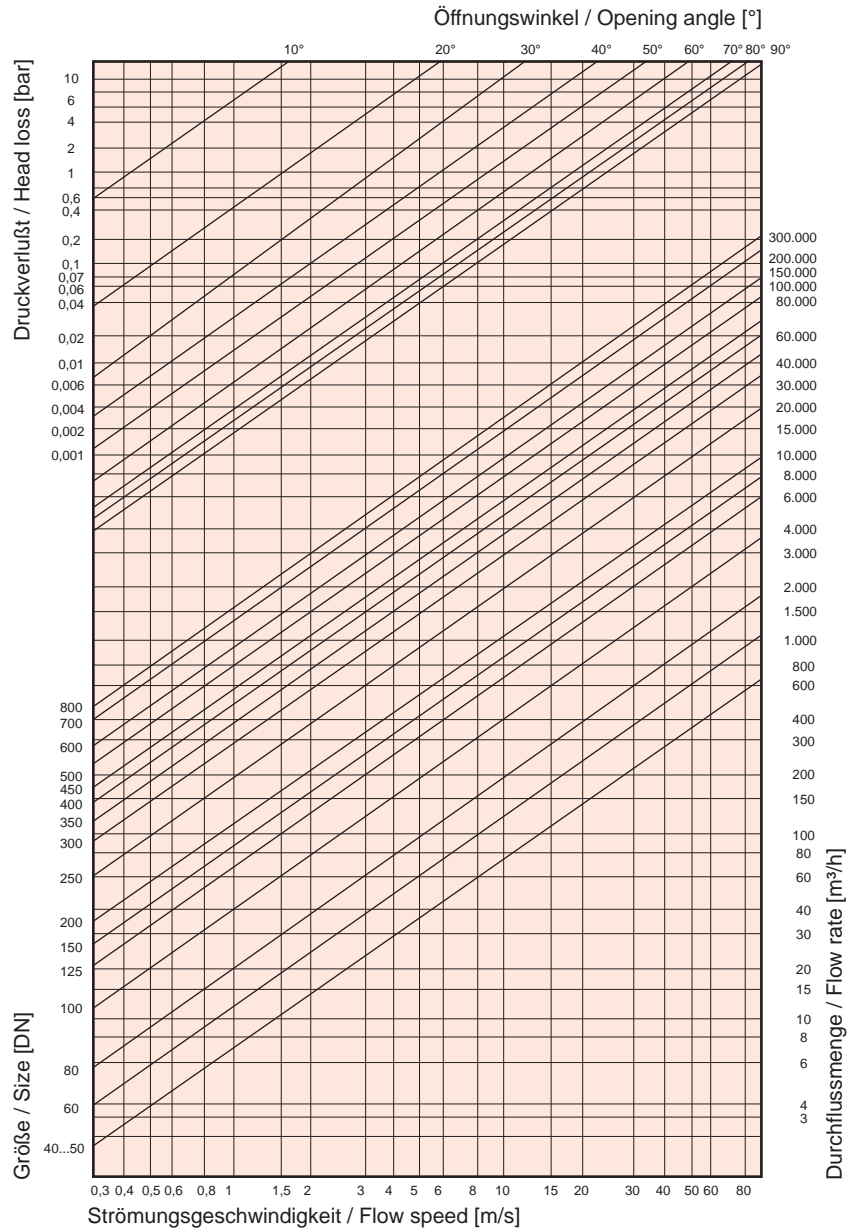

#### Kv-Wert / Kv-rate (Cv = 1,16 · Kv)

Winkel / Angle	40/50	65	80	100	125	150	200	250	300	350	400	450	500	600	700	800
5°	-	-	-	-	-	-	-	-	-	53	68	85	106	151	206	270
10°	-	-	-	-	-	-	-	21	49	123	161	199	246	354	482	926
15°	0,2	0,6	1,8	2,4	4,2	5,6	14	80	188	228	299	369	457	658	900	1168
20°	0,9	2,5	5,2	9,5	15	23	110	156	280	315	412	511	630	907	1234	2010
25°	3,0	6,1	12	22	38	61	125	225	354	457	597	740	914	1314	1789	2735
30°	6,1	11	21	39	69	112	211	310	381	661	863	1069	1320	1899	2585	5080
35°	9,9	18	33	60	105	166	303	433	521	890	1162	1440	1778	2560	3484	6254
40°	15	27	49	88	148	228	405	591	742	1184	1547	1916	2366	3407	4638	9700
45°	21	38	68	121	199	303	528	774	987	1552	2028	2512	3102	4466	6079	11581
50°	29	51	91	159	262	394	679	988	1252	2008	2620	3248	4010	5774	7860	15000
55°	39	68	119	207	338	505	863	1247	1571	2548	3318	4123	5090	7329	9976	17765
60°	53	90	156	269	434	641	1085	1591	2059	3225	4202	5218	6442	9277	12627	22200
65°	72	121	209	357	565	820	1364	2065	2807	3983	5196	6445	7957	11457	15595	26077
70°	92	161	283	487	768	1097	1788	2715	3744	5195	6775	8412	10377	14944	20341	34500
75°	109	209	381	662	1059	1507	2425	3625	4935	6964	9084	11269	13912	20032	27267	39546
80°	115	240	457	815	1303	1861	3043	4768	6831	9301	12142	15048	18578	26752	36413	47560
85°	115	253	502	906	1457	2008	3642	4890	6830	9280	13408	16632	20533	29568	40246	52566
90°	116	257	508	925	1492	2168	3838	5010	6923	9292	14082	17840	22024	31715	43166	56381

REGOM INSTRUMENTS s.r.o.

tel.: +420 241 402 206, +420 241 433 152

fax: +420 241 400 290, +420 241 433 151 e-mail: regom@regom.cz , www.regom.com