

REGOM INSTRUMENTS s.r.o.
Brabcova 1159 / 2
147 00 Praha 4
CZECH REPUBLIC

Tel: +420 241 402 206
Fax: +420 241 400 290
Mail: regom@regom.cz
Skype: regom-office
www.regom.cz

regom
instruments

Technische Daten

BAUFORM

2-teilige Körperkonstruktion (verschraubt).

BETÄTIGUNG

Drehung des Handrades.

ANSCHLUß

- Innengewinde G¹/₂ ... G3 (DIN ISO 228 T1)
- Anschweißenden, DN 15 ... DN 80
 - nach DIN 3239 (**nur DN 15 ... DN 50**)
 - nach ISO 4200 = "L"
 - nach DIN 11850 Reihe 2 = "M"

BETRIEBSDRUCK

Großvakuum bis Nenndruck PN 16 bis +80°C.
Bei Betriebstemperaturen über +80°C siehe Druck-Temperatur-Diagramm.

TEMPERATUR

-20°C bis max. +180°C.

WERKSTOFFE

Gehäuse: Edelstahl 1.4408
Deckel: Edelstahl 1.4408
met. Innenteile: Edelstahl 1.4301
Dichtungen: PTFE

EINBAULAGE

Beliebig, Durchflussrichtung beachten.

Alle Angaben sind freibleibend und unverbindlich.

Specification

DESIGN

Body consists of 2 screwed parts.

OPERATION

Rotation of the handwheel.

CONNECTION

- B.S.P. thread G¹/₂ ... G3 (DIN ISO 228 T1)
- Anschweißenden, DN 15 ... DN 50
 - acc. to DIN 3239 (**nur DN 15 ... DN 50**)
 - acc. to ISO 4200 = "L"
 - acc. to DIN 11850 part 2 = "M"

PRESSURE RANGE

Almost vacuum up to nominal pressure PN 16 up to +80°C. For higher temperatures please refer to the Pressure-Temperature-Diagram.

TEMPERATURE RANGE

-20°C up to +180°C.

MATERIALS

Body: Stainless steel AISI 316
Cap: Stainless steel AISI 316
met. internal parts: Stainless steel AISI 304
Seals: PTFE

MOUNTING

As desired, please refer to the flow direction

The above information is intended for guidance only and the company reserves the right to change any data herein without prior notice!

Artikel:
AE / AD

Schrägsitzventil
PN 16

Edelstahl



Type:
AE / AD

Angle seat valve
PN 16

Stainless steel



Artikel- u. Bestellungenaben: z.B. AD311025

= Schrägsitzventil, Edelstahl / PTFE, Innengewinde G 1

1.+ 2. Stelle Produkt	3.+ 4. Stelle Werkstoffe Gehäuse / Dichtung	5. Stelle Betätigung	6. Stelle Zusatzausstattung	7.+ 8. Stelle Anschlußgröße	
AE= Schrägsitzventil, Anschweißenden AD= Schrägsitzventil, Gewinde	31 = Edelstahl / PTFE	1 = Handrad	0 = ohne	Gewinde	Anschweißenden DIN 3239
				23 = G 1/2 24 = G 3/4 25 = G 1 26 = G 1 1/4 27 = G 1 1/2 28 = G 2 29 = G 2 1/2 30 = G 3	62 = DN 15 63 = DN 20 64 = DN 25 65 = DN 32 66 = DN 40 67 = DN 50 68 = DN 65 69 = DN 80
9.+ 10. Stelle Anschweißenden					
/L = Anschweißenden nach ISO 4200 /M = Anschweißenden nach DIN 11850 Reihe 2					

Ordering example: e.g. AD311025

= Angle seat valve, stainless steel / PTFE, female B.S.P. thread, G 1

1.+ 2. Digit Product	3.+ 4. Digit Materials Body / Seals	5. Digit Operation	6. Digit Options	7.+ 8. Digit Connection size	
AE= Angle seat valve, welded connection AD= Angle seat valve, threaded connection	31 = Stainless steel / PTFE	1 = Hand wheel	0 = without	Threaded connection	Welded connection DIN 3239
				23 = G 1/2 24 = G 3/4 25 = G 1 26 = G 1 1/4 27 = G 1 1/2 28 = G 2 29 = G 2 1/2 30 = G 3	62 = DN 15 63 = DN 20 64 = DN 25 65 = DN 32 66 = DN 40 67 = DN 50 68 = DN 65 69 = DN 80
9.+ 10. Digit Welded connection type					
/L = Welded connection acc. to ISO 4200 /M = Welded connection acc. to DIN 11850 part 2					

Druck-Temperatur-Diagramm / Pressure-Temperature-Diagram

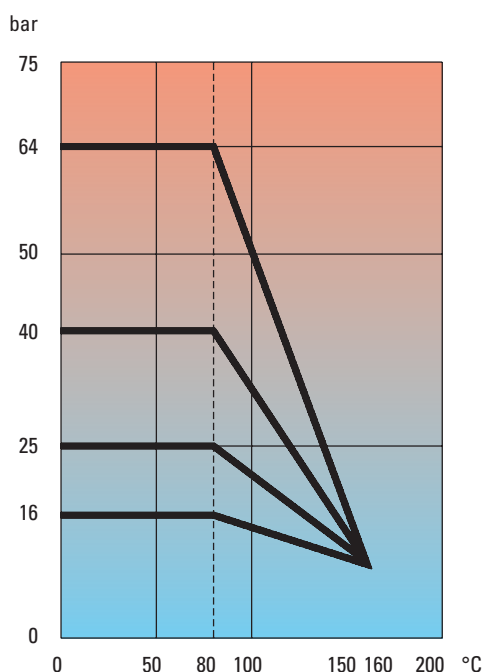

Stückliste / Parts list

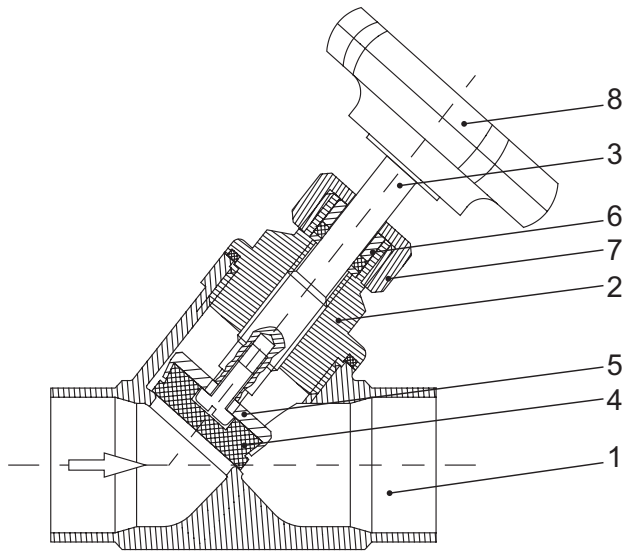

Pos.	Bezeichnung / Description		Material / Material	
1	Gehäuse	Body	Edelstahl	Stainless steel
2	Einschraubteil	Screw joint	Edelstahl	Stainless steel
3*	Spindel	Stem	Edelstahl	Stainless steel
4*	Sitzdichtung	Seat seals	PTFE	PTFE
5*	Ventilteller	Valve disc	Edelstahl	Stainless steel
6*	Packung	Packing	Edelstahl, PTFE	Stainless steel, PTFE
7	Sechskantmutter	Hexagon nut	Edelstahl	Stainless steel
8*	Handrad	Hand wheel	Kunststoff	Plastic

*: Diese Teile sind als Ersatzteile auf Anfrage erhältlich.

Bitte beachten: Die Teile der Positionen 3 - 5 sind nur vormontiert als eine Einheit erhältlich!

*: These parts are available as spare parts.

Please observe: The parts No. 3 - 5 are only available completely mounted as one component!

Abmessungen / Dimension

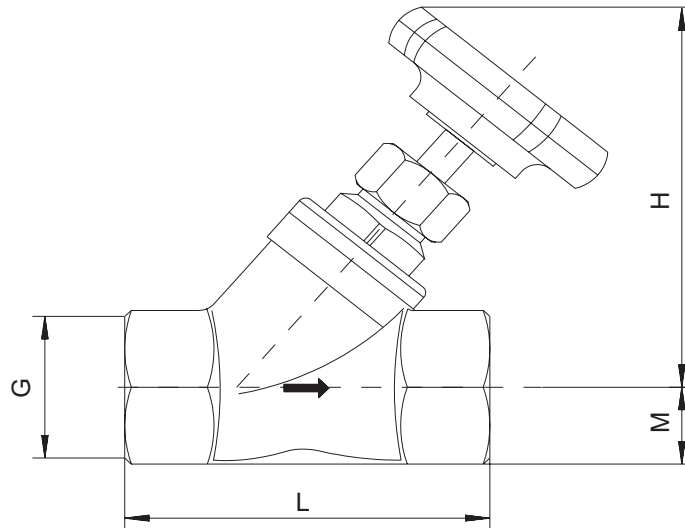

G	M	L	H	kv [m³/h]
1/2	12,5	65	97	4,6
3/4	15,5	75	110	9,5
1	18,5	90	117	15,5
1 1/4	23,0	110	138	21
1 1/2	26,5	120	150	26,5
2	33,5	150	168	46
2 1/2	42,5	180	195	
3	50,0	200	205	



Abmessungen / Dimension

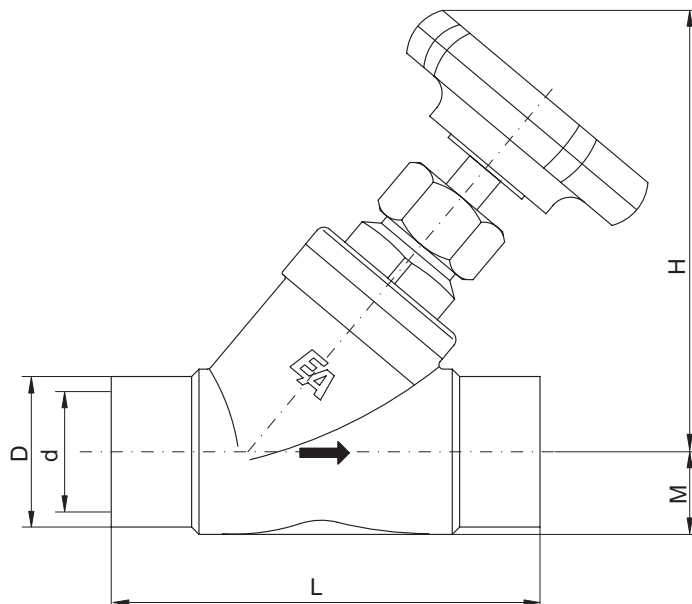

Anschweißenden DIN 3239
Butt welding DIN 3239

"L"- Anschweißenden ISO 4200
"L"- Butt welding ISO 4200

"M"- Anschweißenden DIN 11850-2
"M"- Butt welding DIN 11850-2

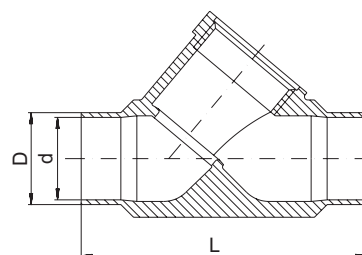
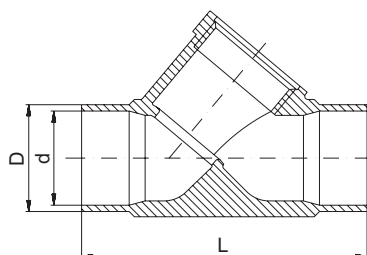
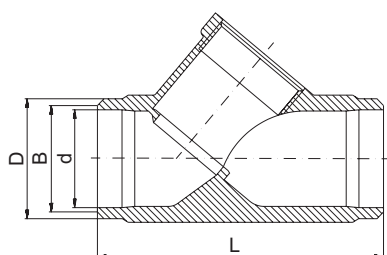

DN	M	L	H	kv [m³/h]	DIN 3239			„L“ - ISO 4200		„M“ - DIN 11850-2	
					ØD	ØB	Ød	ØD	Ød	ØD	Ød
15	12,5	65	97	4,6	24	22	17	21,3	18,1	19	16
20	15,5	75	110	9,5	30	28	22	26,9	23,7	23	20
25	18,5	90	117	15,5	36	34	28	33,7	29,7	29	26
32	23,0	110	138	21	45	41	35	42,4	38,4	35	32
40	26,5	120	150	26,5	52	49	43	48,3	44,3	41	38
50	33,5	150	168	46	65	61	54	60,3	55,1	53	50
65	42,5	205	195		-	-	-	76,1	70,3	70	66
80	50,0	220	205		-	-	-	88,9	83,1	85	81

EU-Herstellererklärung / EU-Declaration by the manufacturer

im Sinne der EU-Maschinenrichtlinie 98/37/EG (früher 89/392/EWG, Anhang II B)
Hiermit erklären wir, dass die Kugelhähne unter Anwendung nachfolgender harmonisierter Normen entwickelt und konstruiert wurden:

EN 292	Sicherheit von Maschinen
EN 983	Fluidtechnische Anlagen - Pneumatik
EN 60204-1	Elektrische Ausrüstung von Maschinen

Hinweis
Die Kugelhähne sind zum Einbau in eine Maschine bestimmt. Deren Inbetriebnahme ist solange untersagt, bis festgestellt wurde, dass die Gesamtmaschine der EU-Richtlinie entspricht, as defined by Machinery Directive 98/37/EC (former 89/392/EWG, Annex II B),

we herewith declare that the ball valves have been developed and designed by applying the following harmonised standards:

EN 292	Safety of machinery
EN 983	Safety requirements for fluid power systems and components - Pneumatics
EN 60204-1	Electrical equipment of machinery

Advice
These ball valves are intended to be incorporated into machinery compounds. Putting into operation of the machinery is not allowed until such time as the entire machinery is proving to comply completely with the EU Directive.

REGOM INSTRUMENTS s.r.o.
tel.: +420 241 402 206, +420 241 433 152
fax: +420 241 400 290, +420 241 433 151 e-mail: regom@regom.cz , www.regom.com