

**Type SGS-02-11-IO****basic @ level**

Limit switch for the food industry

Basic Features

- ▶ One limit switch for watery and oily media
- ▶ Two steady adjusted switch on /off treshold, free parametrizable with IO-link
Standard: watery media
- ▶ welding sleeve-system with modular process conections
- ▶ Aseptic measuring point
- ▶ Wetting parts made of peek
- ▶ Display of the switching state via brighth TOP LED illuminated ring of PA-GF20
- ▶ Very high meauring dynamic
- ▶ Partly moulded
- ▶ EHEDG certified, FDA-conformal

Technical Features

- ▶ High-grade steel connecting head
Material No. 1.4404 (316L)
- ▶ Connection: M12 plug (1.4301) 4 pole for IO link
- ▶ Thread G 1/2" elastomerfree sealing system
- ▶ Sensor heads made of Peek (HPC-Tip No. 2)
- ▶ CIP-/SIP cleaning 0... + 130°C (<1h) with ambient temperature 40°C
- ▶ Supply Voltage 12...32 VDC
- ▶ Output signal PNP (standard), NPN or Push-Pull switchable/ NC, NO switchable
- ▶ Power up delay < 0,3s
- ▶ Response time 0,2s
- ▶ Ambient temperature -10...+70°C
- ▶ Medium temperature durable 0...+100°C
- ▶ Storage temperature -20...+70°C
- ▶ Working pressure 10 bar bar (Higher pressures on request)
- ▶ Protection class IP67
- ▶ Torque max. 20 Nm
- ▶ Permissible Load: 100mA

Favoured fields of application are e.g:

The smw is a micro-processor controlled limit switch for liquids or paste-like and adhesive medias.

- ▶ Low- / high alarm in containers
- ▶ Media registration in pipes as pump protection
- ▶ Fill level detection of liquids in containers + pipes

**Approvals**

EHEDG, Hygienic Peek Connect G 1/2" (HPC)

Certificate Number 21/2017

Certificate only valid in combination with an EHEDG process tip (HPC tip) and process adapter (HPC sleeve). Permissible process adapters see data sheet
"Process adaptation"

Interface

Type of data transfer	COM2 (38,4 kBaud)
IO-Link revision	1.1
SDCI-norm	IEC 61131-9

Notice

Suitable for applications with predominantly aqueous media, mild, beer, Cip - liquids. Very adhesive media can lead incorrect measurements.

Relevant welding sleeves on request.

The sealing of the sensor must have an intact electrical connection of the G1/2" thread and the container wall. Do not use any sealing strips



Type SGS-02-11-IO

basic @ level

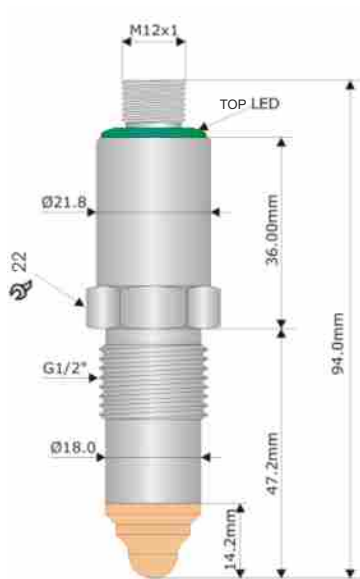

SGS-02-11-S

Pin Configuration

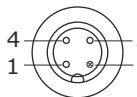

- 1 (BN) +VDC
- 2 (WH) OUT 2
- 3 (BU) GND
- 4 (BK) OUT 1 (IO-LINK)

Installation Notes

Torque PEEK-Tip (HPTC-Tip) with sleeve (HPC-Sleeve): 20Nm



Example of modular process adaption



BP 15



HP 15



TP 15

See Data sheet Process Connections



Order code

SGS- 02 - 11 - IO