

Pressure Control Valves

Safety Valves SV 29

Normal or Full Lift Threaded Valve



Technical Data

Connection DN	15 - 25
Connection G	3/8A - 1A
Nominal Pressure PN	40 - 400
Set Pressure	0.1 - 330
Temperature	280°C
Medium	liquids, gases and steam

Description

Safety valves are the ultimate protection device for tanks and pipelines. They prevent pressure limits being exceeded once all automatic control and monitoring equipment has failed.

SV 29 is a spring-loaded normal safety valve with threaded connection and closed spring cap. Component testing for connection sizes G 1/2 and G 3/4 for steam and gases up to 150 bar and liquids up to 40 bar.

Normal safety valves initially open proportionally up to a pressure rise of 10 %. This initial phase is followed by the full opening of the valve, allowing a large flow of medium.

Especially in the case of liquids, the wide proportional range results in a continuous operation.

Pressure rise:

above 1 bar set pressure:10 % up to required valve lift;
below 1 bar set pressure:0.1 bar.

Options

- » Special connections: ANSI flanges, NPT, other connections on request
- » Special versions on request

Operating instructions, know how and safety instructions must be observed. All the pressure has always been indicated as overpressure. We reserve the right to alter technical specifications without notice.



Available Versions

H2	without lifting device, gastight cap
H4	with lifting device, gastight cap

kombinierbare Gehäusevarianten

outlet body			
G	1/2	3/4	1
DN	15	20	25
inlet body			
G	3/8A	1/2A	3/4A 1A
DN	15	20	25

Pressure Control Valves

Safety Valves SV 29

Normal or Full Lift Threaded Valve



Materials		
Temperature	220 °C	280 °C
Inlet Body	1.4104*, 1.4404 stelled	1.4404 stelled
Outlet Body	1.4104	1.4404
Cap	1.0718	1.4404
Spindle	1.4021	1.4571
Spring Plate	1.4104	1.4404
Adjusting Screw	1.4104	1.4404
Spring	1.4310	1.4310

*only G 3/8, G 1/2, G 3/4

Dimensions [mm] Male End Connection				
G Inlet	3/8 A	1/2 A	3/4 A	1 A
A	30	30	37	37
B	33	33	33	36
C	208	210	212	217
D	12	14	16	18

Weights [kg] Male End Connection			
G 1/8	G 1/2	G 3/4	G 1
1.2	1.2	1.6	1.6

Dimensions [mm] Flange Connection				
PN	size	nominal diameter DN		
		15	20	25
		40	A	100
	B	100	100	100
	C	263	263	263
160	A	100	100	100
	B	103	103	103
	C	287	287	287

Other pressure rates on request. The outlet dimension b can differ at special combinations of nominal diameter and pressure range if flanged connections are used at the inlet and outlet. Special dimensions are possible.

Weights [kg] Flange Connection	
to calculate the total weight please use the following formular: $m_N + m_F$ (inlet) + m_F (outlet)	
net weight m_N [kg] (without inlet and outlet flanges)	2.4

Flange Dimensions [mm] and Weights m_F [kg]				
PN	size	diameter DN		
		15	20	25
		40	D	18
	m_F	0.8	1.1	1.3
100	D	-	22	-
	m_F	-	1.3	-
160	D	22	-	26
	m_F	1.2	-	2.6
250	D	28	-	30
	m_F	2.5	-	3.5
320	D	28	-	36
	m_F	2.5	-	5
400	D	30	-	40
	m_F	3.6	-	7.5

Customs Tariff Number
84814010

Special designs on request. The pressure has always been indicated as overpressure. Mankenberg reserves the right to alter or improve the designs or specifications of the products described herein without notice.

Dimensional Drawing

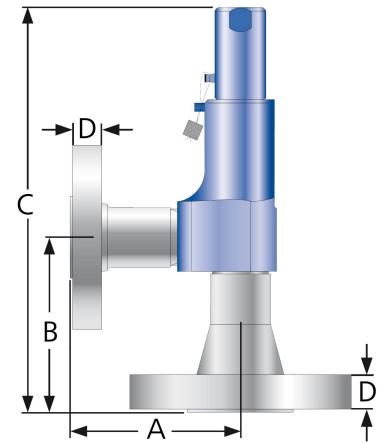
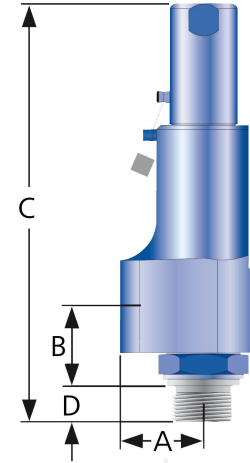

Pressure Control Valves

Safety Valves SV 29

Normal or Full Lift Threaded Valve



Flow Rate				
seat [mm]	set pressure[bar]	saturated steam [kg/h]	air [Nm ³ /h]	water [m ³ /h]
do = 10	0,1	12	14	0,63
	0,2	17	19	0,77
	0,5	29	34	1.08
	1	43	51	1.5
	2	70	84	2.1
	3	94	115	2.5
	4	118	145	2.9
	5	141	174	3.3
	6	164	204	3.6
	8	209	262	4.1
	10	255	321	4.6
	16	392	498	5.9
	20	483	615	6.6
	26	619	792	7.5
	30	712	909	8.0
	40	943	1204	9.3
	50	1181	1498	10.4
60	1421	1792	11.4	
70	1670	2086	12.3	
80	1921	2380	13.1	
90	2185	2674	13.9	

Special designs on request.

The pressure has always been indicated as overpressure.

Mankenberg reserves the right to alter or improve the designs or specifications of the products described herein without notice.